

Integrating Global Communications . . .

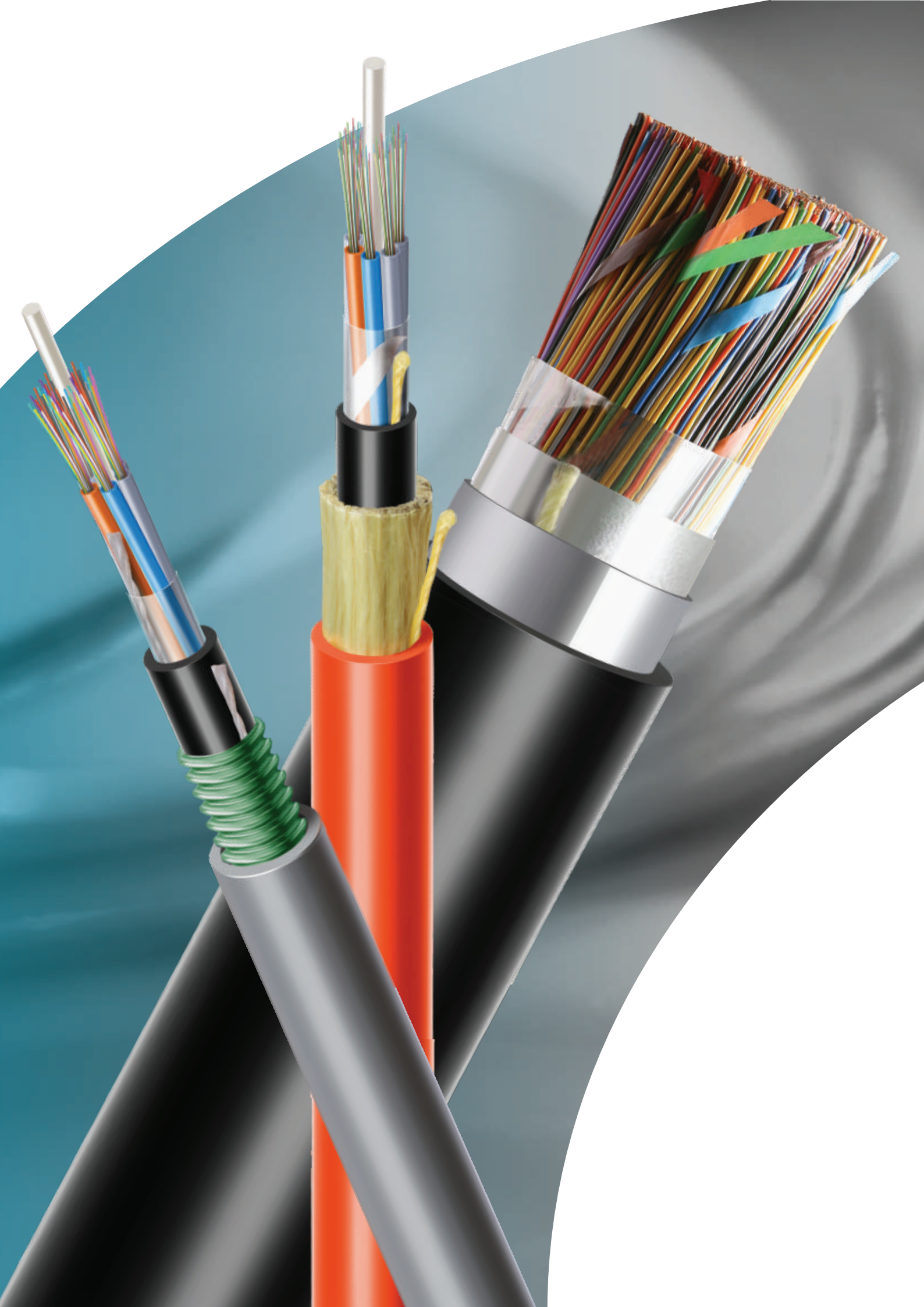



FIBRE OPTIC CABLES

AERIAL

ADSS (All Di-Electric Self Supporting)

UNI-TUBE	
2F-24F Single Jacket	16
MULTI-TUBE	
6F-144F Single Jacket - Micro Module	40
6F-288F Single Jacket - Micro Module	41
6F-288F Single Jacket	28
6F-288F Double Sheath	29
ULTRA-LIGHT WEIGHT	
12F-96F Single Jacket - Micro Module	43
2F-96F Single Sheath - Compact Fibre Unit	49

Fig 8 (Metallic - Messenger Wire)

UNI-TUBE	
2F-24F Single Jacket	30
MULTI-TUBE	
2F-288F Single Jacket	31

Fig 8 (Dielectric - Messenger Wire)

MULTI-TUBE	
12F-144F Single Sheath FRP	32

UNDERGROUND DUCT

DIELECTRIC

UNI-TUBE	
2F-24F Single Jacket - Unarmoured	10
2F-24F Single Jacket - Glass Yarn Armoured	27
MULTI-TUBE	
12F-864F Single Sheath- Unarmoured	11
12F-288F Single Sheath- Glass Yarn Rodent Protected	17
12F-1152F Single Sheath- Micro Module - 2FRP	42
6F-144F Single Sheath- Micro Module - 4FRP - ADSS	40
12F-288F Double Sheath Ribbon Type	24
48F-1728F Single Sheath- Ribbon Type	26
12F-288F Double Sheath- Glass Yarn Rodent Protected	18
12F-288F Double Sheath- FRP Rod - Armoured	22
192F-288F Double Sheath- Unarmoured	12
12F-144F Triple Jacket - FRP - Armoured	23

METALLIC

UNI-TUBE	
2F-24F Single Sheath - ECCS Tape - Armoured	13
2F-24F Double Sheath- Steel Wire - Armoured	19
MULTI-TUBE	
12F-288F Single Sheath - ECCS Tape - Armoured	14
12F-288F Double Sheath - ECCS Tape - Armoured	15
12F-144F Double Sheath - Steel Wire -Armoured	20
48F-864F Double Sheath- ECCS Tape - Ribbon Type	25
12F-144F Triple Jacket - Steel Wire - Armoured	21

MICRODUCT

UNI-TUBE	
2F-24F Single Nylon Jacket 2.5mm	55
2F-24F Single HDPE Jacket 3.5mm	55
2F-24F Single HDPE Jacket 2.5mm 200um	55
MULTI-TUBE	
12F-576F Single Jacket - 200 Um	36
12F-576F Single Jacket - 250 Um	37
SUPER LEAN 200 MICRON	
2F - 96F Multi-Tube - Single Jacket 3.8/4.6mm	38

MICROMODULE

UNI-TUBE	
2F-24F Single Jacket - Drop Cable	39
MULTI-TUBE	
12F-1152F Single Jacket - 2FRP - Duct	42
12F-288F Single Jacket - 4FRP - Duct - ADSS	40
12F-48F Fan out - Double Sheath- Glass Yarn Armoured - Dielectric	53
12F-48F Fan out - Double Sheath- ECCS Tape Armoured - Non Dielectric	52
2F-48F Fan out - Tight Buffered - Unarmoured	51

FTTX

FLAT DROP	
2F-48F FRP-Embedded	35
1F-4F Fig 8 Drop	34
1F-4F Flat Drop	54

SPECIALITY

2F-12F Steel Wire Armoured - Tactical	48
2F-6F Spiral Armoured	46
2F-6F Retractable	50
2F-6F Fibre to Antenna	44
Hybrid (Optical & Copper) Under Ground Armoured	33
Spiral Furcation tube	47
2F-6F Spiral Double Sheath with Wire Braiding	45

INDOOR

UNI-TUBE	
Interconnect Cable	58

Index

STRUCTURED CABLES

CAT 7

CAT 7 4 Pair 24AWG U/FTP Cable	79
CAT 7 4 Pair 24AWG S/FTP Cable	80

CAT 6

CAT 6 4 Pair 23AWG S/FTP Armoured Cable	81
CAT 6 4 Pair 24 AWG UTP FRPVC CABLE	82
CAT 6 4 Pair 23 AWG UTP FRPVC CABLE	83
CAT 6 4 Pair 23AWG UTP Armoured Cable	84

CAT 6A

CAT 6A 4 Pair 23AWG F/UTP Double Sheath Cable	85
CAT 6A 4 Pair 23AWG U/FTP LSZH Cable	86
CAT 6A 4 Pair 23AWG UTP ARMOURED Cable	88
CAT 6A 4 Pair 23AWG S/FTP LSZH Cable	89
CAT 6A 4 Pair 23AWG UTP FRPVC Cable	90
CAT 6A 4 Pair 23AWG S/FTP Cable	87
CAT 6A 4 Pair 23AWG F/UTP FRPVC Cable	91

CAT 5E

CAT 5E 4 Pair 24AWG UTP Drop Cable	92
CAT 5E 4 Pair 24AWG UTP Cable	93
CAT 5E 4 Pair 24AWG SF/UTP Cable	94
CAT 5E 4 Pair 24AWG F/UTP Cable	95

POWER CABLES

COPPER CABLES

Foam Skin / Solid PE Insulated Jelly Filled Telephone Cable	61
Self Supporting Aerial (Figure 8 Type) Telephone Cable	62
Underground Jelly Filled Quad Cable	63
Signaling Cable	64
Jumper Wire	65
Electroplated Tinned Copper Wire	66

POWER CABLES

LT Aerial Bunched Cable	69
Instrumentation Cable	71
Control Cable	73
PVC Insulated Industrial Cable (Unsheathed)	75
PVC Insulated Industrial Cable (Sheathed)	76





M. P. Birla Group

Profile

Established in 1919, Birla Corporation Ltd., then known as the Birla Jute Manufacturing is the flagship company of the MP Birla Group. Under the dynamic and able leadership of its late Chairman Madhav Prasad Birla, the company through its vigor have kept themselves abreast of changing needs of customers and advances in technologies and have continuously innovated. Over the years the MP Birla Group companies have been entering into tie-ups and collaborations with major players of international repute in order to develop new and innovative products for its customers both in India and the international market.

Some of the major companies that fall under the umbrella of the M. P. Birla Group are:

COMPANY	PRODUCT
Birla Corporation Limited	Cement, Jute, Carbide, etc.
Birla Cable Limited	Optical and Copper Telecommunication Cables, etc.
Vindhya Telelinks Limited	Copper and Optical Telecommunication Cables, etc.
Universal Cables Limited	EHV, HT and LT Power Cables and Capacitors, etc.
Birla Furukawa Fibre Optics Limited	Optical Fibres
Hindustan Gum and Chemicals Limited	Guar Gum and Allied Products
Birla Visabeira Pvt. Ltd.	Specialised Turnkey Projects

Some of the Other Companies, Trusts and Investment Companies under the Group

COMPANY	
1 Mazbat Tea Estate Ltd.	9 Express Dairy Co.Ltd.
2 Baroda Agents & Trading Co.Pvt Ltd.	10 Gwalior Webbing Co.Pvt.Ltd.
3 Belle Vue Clinic	11 M.P.Birla Institute of Fundamental Research.
4 Birla Financial Corporation Ltd.	12 Priyamvada Birla Arvind Eye Hospital
5 Bombay Hospital Trust & Medical Research Institute	13 Priyamvada Birla Cancer Research Institute
6 East India Investment Co.Pvt Ltd.	14 M.P.Birla Eye Clinic
7 Eastern Economist Ltd.	15 Seva Nidhi Trust
8 The Punjab Produce & Trading Co. Pvt Ltd.	16 Varunendra Trading & Agents Pvt. Ltd.

The Group owes its success to its commitment to quality and customer satisfaction. All companies within the Group have ISO 9001:2000 certification for Quality Management Systems; the group companies have kept themselves abreast of changing needs of customers and advances in technologies and have continuously innovated. Over the years the MP Birla Group companies have been entering into tie-ups and collaborations with major players of international repute in order to develop new and innovative products for its customers both in India and the international market.

MP Birla Group is also a responsible Corporate citizen, the Group companies have consciously worked towards a secure environment. All group companies have ISO 14001:2004 certification for Environment Management System. The Group companies not only conform to statutory requirements but are committed to maintaining the ecological balance at its various campuses. Besides this the MP Birla group is also involved in various charitable and philanthropic activities in the field of education, healthcare, scientific research, as well as in the areas of literature and culture and is also involved in pure charitable activities.



Birla Cable Limited

Profile

Birla Cable Limited (Formerly known as Birla Ericsson Optical Limited) is a premier company in the field of Telecommunication Cables, which offers one of the widest portfolio of Copper and Fibre Optic cables under its umbrella. A division under India's one of the most trusted M. P. Birla Group, Birla Cable Limited has come a long way to establish itself as one of the most admirable player in Global arena among users of Telecom cables due to its superior product quality, stringent quality control systems and flawless performance across all the segments of Telecom users.

It all started in the year 1992, having technology collaboration and financial partnership with globally renowned Ericsson Network Technologies AB of Sweden as a Joint Venture Company. This Cable manufacturing company of M.P. Birla Group has crossed leaps and bounds during the last, almost 3 decades of association with Ericsson, in not only equipping itself as one of the versatile cable manufacturing and total solutions providing company but also kept abreast with latest technology trends from time to time on a continuous basis. This unique and disruptive approach followed by the company catapulted it as a qualified globally certified company having various approvals with renowned certifying bodies and institutions in the field of Oil & Gas, Power and Telecom segments.

By way of acquiring the shares of Ericsson recently, Birla Cable Limited has become a truly global Indian Company which has a reach of more than 60 countries, fully capable to cater to all the needs of communication cables across the segments. A competent team in all functional areas backed up by strong and experienced management, sound financial and technical strength makes Birla Cable Limited, a trusted name among the users of Telecom Cables.

The company possess all the required quality certifications like Quality Management System, Environment and Health & Safety Management Systems in an integrated manner with its state of the art cable manufacturing facilities located in Rewa, Madhya Pradesh, India and always on the drive to expand its Product base and Market reach.



Vindhya Telelinks Limited

Profile

Vindhya Telelinks Limited is the outcome of a Public-Private joint venture between Universal Cables Limited and the Madhya Pradesh State Industrial Development Corporation Limited. At the time of its conception, Vindhya Telelink's primary mandate was to manufacture Jelly Filled Telephone Cables (JFTC). With the completion of its manufacturing plant at Rewa (M.P.) Vindhya Telelinks commenced commercial production in 1986.

Today, Vindhya Telelinks has emerged a leading manufacturer & supplier of Jelly Filled Telecommunication Cables, as well as of Optical Fiber Telecommunication Cables. The modest initial manufacturing capacity of JFTC has increased manifold and is offered in a wide range of offerings from 5 Pair to 2400 Pair. Optical Fiber Cables employing the most current technology are also manufactured at a robust capacity annually. Vindhya Telelinks undertakes all manufacturing & production under the stringent parameters of the ISO 9001 & ISO 14001 Certifications.

All of the company's systems & processes are geared to comply fully with ISO guidelines, are subject to ongoing scrutiny under the certification, are constantly improved to meet the ISO requisites; and ultimately yield a very high level of Customer Satisfaction. Vindhya Telelink's reputation as a dependable & high quality manufacturer now precedes itself. We have been consistently awarded the highest Delivery Rating amongst Telephone Cable manufacturers. Our unblemished history & superior quality enabled us to work under the coveted Approved Inspection Scheme (AIS), a rare privilege for a company.

Our regular clients include top telecom companies such as BSNL, MTNL, NTPC, & Reliance Infocom and we are now also the proud Preferred Vendors to Bharti & Tata for Copper Telephone Cables & Optical Fiber Cables. Additionally, Vindhya Telelinks is proud to provide its product range to the Railways, Defense, Coalfields, SAIL and Atomic Energy among others. In a bid to forge ahead strongly into the future; Vindhya Telelinks is undertaking several new initiatives. Our Optic Fiber Goa Limited, along with Universal Cables & Birla Ericsson Optical Limited, has been set up to manufacture Optic Fiber in Goa. We have also put in place our EPC Division, that provides complete turn-key solutions including trenching, laying, jointing, & installation of Telecom Cables



*Travel towards the future
at the speed of light*

Fibre Optic Cables

2F-24F CENTRAL-TUBE UNARMOURD OPTICAL FIBRE CABLE



Applications

- Suitable for Duct Installation
- For CATV application, aerial application along with messenger wire



Typical Cross section of 24 Fibre

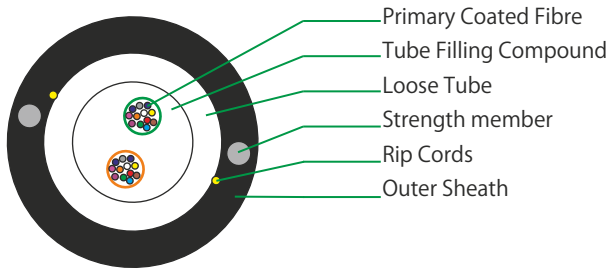

Cable Construction Details

- Up to 48 enhance low water peak single mode fibres in full compliance with ITU-T-G.652.D (also available with G655 / G656 / G657 SM Fibre and OM1 / OM2 / OM3 & OM4 MM Fibre)
- Metallic, anti-buckling Steel rod as Strength Member. embedded in outer sheath (also available with non metallic strength member, FRP rod)
- Loose buffer tube fully filled and Centrally placed in the cable
- UV Stabilized PE outer sheath, black (also available with HFFR/FR PVC)

Technical Characteristics

FIBRE COUNT	DIAMETER (mm) Nominal	WEIGHT (Kg./Km) Nominal	TENSILE STRENGTH (N)		BENDING RADIUS (mm)		TEMPERATURE RANGE (IEC 60794-1-2-F1)	
			Installation	Operation	Installation	Operation	Installation	Operation
UPTO 12F	6.5	30	400	200	10D	20D	-10° to +50° C	-40° to +70° C
24F	7.0	40	400	200	10D	20D	-10° to +50° C	-40° to +70° C

Colour Coding - Fibre



* For Fibre count more than 12F, bundles in multiple of 12F will be formed with color identification binder (Blue, Orange, Green & Brown)

Special Features

Lighter weight cable for faster and easier installation

Drum Length

2000/ 4000 meters ± 5%

Mechanical Characteristics

Repeated Bending [IEC 60794-1-2-E6]	30 Cycle, r= 20 X D, 5 Kg Load, D = D = Cable Diameter
Torsion Resistance [IEC 60794-1-2-E7]	10 Cycle (± 360°) 5 Kg Weight, L= 2 Mtr
Crush Resistance [IEC 60794-1-2-E3]	1000 N (100 X 100 mm) for 600 sec
Impact Resistance [IEC 60794-1-2-E4]	5nm, 3 Nos
Kink Resistance [IEC 60794-1-2-E10] 10 x D, D = Cable D	
Water Penetration [IEC 60794-1-2-F5B]	1 Mtr Water Head, 3 Meter Cable Sample, 24 Hours

12F-864F MULTI-TUBE SINGLE SHEATH UNARMoured CABLE

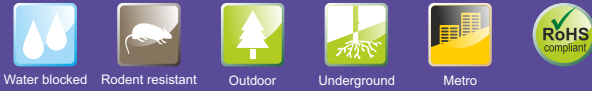

Applications

Suitable for Duct Installation, pulled & blown.

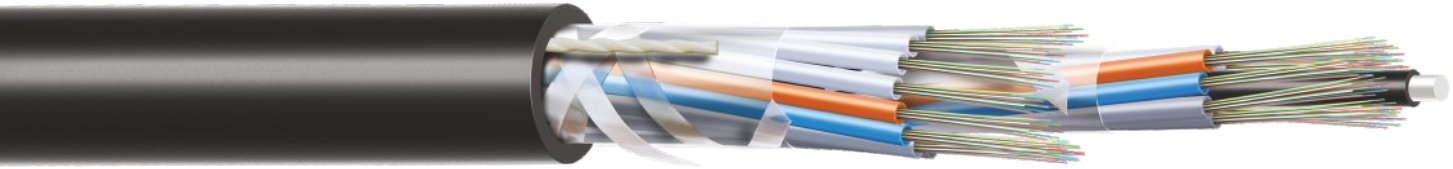

Typical Cross section of 864 Fibre

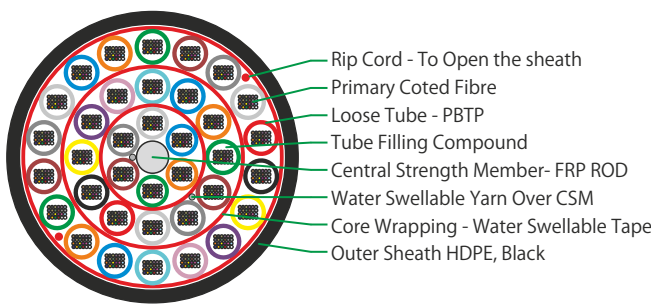

Cable Construction Details

- Up to 864 enhance low water peak single mode fibres in full compliance with ITU-T-G.652.D (also available with G655 / G656 / G657 SM Fibre and OM1 / OM2 / OM3 & OM4 MM Fibre).
- 6/8/12/24 fibre per tube combinations are available in 6/8/12/18/24/36 element constructions.
- Non metallic anti-buckling FRP rod as Central Strength Member.
- Loose buffer tubes fully filled with Thixotropic Jelly & Fibers.
- Loose buffer tubes S-Z Stranded (Water Swallowable Yarn over CSM).
- Cable core is Dry & wrapped with water swallowable tape.
- UV Stabilized PE outer sheath, Black (also available with FR PVC & HFFR).
- Rip cord to open the sheath.

Technical Characteristics

FIBRE COUNT	FIBRE PER TUBE	DIAMETER (mm) Nominal	WEIGHT (Kg./Km) Nominal	TENSILE STRENGTH (N)		BENDING RADIUS (mm)		TEMPERATURE RANGE (IEC 60794-1-2-F1)	
				Installation	Operation	Installation	Operation	Installation	Operation
12-72	(12F/Tube)	10.0	77	2000	1000	10D	20D	-10°C to +50°C	-40°C to +70°C
96	(12F/Tube)	11.4	105	4400	2400	10D	20D	-10°C to +50°C	-40°C to +70°C
144	(12F/Tube)	14.0	155	4800	2800	10D	20D	-10°C to +50°C	-40°C to +70°C
192	(12F/Tube)	14.6	150	3500	1800	10D	20D	-10°C to +50°C	-40°C to +70°C
216	(12F/Tube)	14.6	150	3500	1800	10D	20D	-10°C to +50°C	-40°C to +70°C
288	(12F/Tube)	16.5	200	4500	2400	10D	20D	-10°C to +50°C	-40°C to +70°C
432	(24F/Tube)	16.8	205	5200	2600	10D	20D	-10°C to +50°C	-40°C to +70°C
576	(24F/Tube)	19.5	280	7500	4000	10D	20D	-10°C to +50°C	-40°C to +70°C
720	(24F/Tube)	22.5	345	7600	4000	10D	20D	-10°C to +50°C	-40°C to +70°C
864	(24F/Tube)	22.5	355	9000	4500	10D	20D	-10°C to +50°C	-40°C to +70°C

Fibre & Tube colour coding

Without ring mark



With ring mark



- More than 12 fibre we provide Black ring mark above the colored fibre.
- More than 12 Tube we provide Stripe above the colored tube.

Special Features

- Single Double & Triple layer S-Z stranded construction.
- Flexible buffer tubes provide easy fibre routing inside closure.
- Light in weight, hence easy to install.

Drum Length

2000/ 4000 meters ± 5%

Mechanical Characteristics

Cable Bending Radius (mm) [IEC 60794-1-21-E11 A & B]	20 X D, D= Cable diameter
Impact Resistance (Nm) [IEC 60794-1-21-E4]	5 Nm, 3 Impacts
Crush Resistance (N) [IEC 60794-1-21-E3]	2000 N (100 X 100 mm)
Torsion Resistance [IEC 60794-1-21-E7]	10 Cycle (± 180°)
Water Penetration [IEC 60794-1-22-F5 B]	1 Meter Water Head, 3 Meters Cable Sample, 24 Hours

12F-288F DOUBLE SHEATH MULTI-TUBE UNARMoured OPTICAL FIBRE CABLE



Application

- Suitable for Duct Installation, pulled & blown



Typical Cross section of 72 Fibre

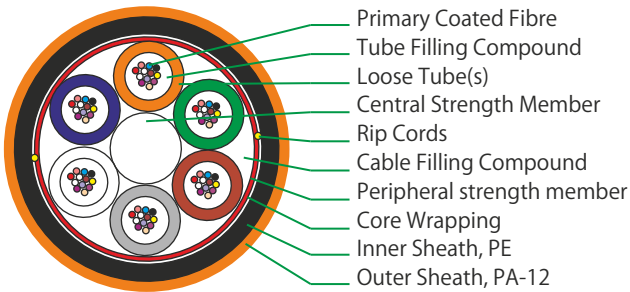

Cable Construction Details

- Up to 288 enhance low water peak single mode fibres in full compliance with ITU-T-G.652.D (also available with G655 / G656 / G657 SM Fibre and OM1 / OM2 / OM3 & OM4 MM Fibre)
- 6/8/12 fibre per tube combinations are available in 6/8/12 element construction
- Non metallic anti-buckling FRP rod as Central Strength Member (also available with Steel rod)
- Loose buffer tubes fully filled, S-Z Stranded
- Cable core fully filled with jelly (also available in dry core)
- Glass yarn can be used as peripheral strength member
- S-Z core wrapped with polyester tape / water swellable tape
- UV Stabilized HDPE inner sheath, Black
- Insect & termite resistant PA-12 outer sheath
- Outer Sheath PA12, Orange
- Rip Cord to open the sheath

Technical Characteristics

FIBRE COUNT	DIAMETER (mm) Nominal	WEIGHT (Kg./Km) Nominal	TENSILE STRENGTH (N)		BENDING RADIUS (mm)		TEMPERATURE RANGE (IEC 60794-1-2-F1)	
			Installation	Operation	Installation	Operation	Installation	Operation
UPTO 72F	11	88	2000	1200	10D	20D	-10° to +50° C	-40° to +70° C
96F	12.5	120	4800	2800	10D	20D	-10° to +50° C	-40° to +70° C
144F	14.8	170	5000	3000	10D	20D	-10° to +50° C	-40° to +70° C
192F-216F	15.5	170	3600	1200	10D	20D	-10° to +50° C	-40° to +70° C
288F	17.4	220	4800	2700	10D	20D	-10° to +50° C	-40° to +70° C

Colour Coding - Fibre & Tube



Special Features

- Single layer S-Z stranded construction
- Flexible buffer tubes provide easy fibre routing inside closure
- Light in weight, hence easy to install
- Insect & termite resistant

Drum Length

2000/ 3000/ 4000 meters ± 5%

Mechanical Characteristics

- Repeated Bending [IEC 60794-1-21-E6] 30 Cycle, r= 20 X D, 5 Kg Load, D = Cable Diameter
- Torsion Resistance [IEC 60794-1-21-E7] 10 Cycle (± 360°) 5 Kg Weight, L= 2 Mtr
- Crush Resistance [IEC 60794-1-21-E3A] 2500 N (100 X 100 mm) for 600 sec
- Impact Resistance [IEC 60794-1-21-E4] Height 500 mm, Weight = 5 Kg, 3 Nos
- Kink Resistance [IEC 60794-1-21 E10] 10 x D, D = Cable D
- Water Penetration [IEC 60794-1-22-F5 B] 1 Mtr Water Head, 3 Meter Cable Sample, 24 Hours

**2F-24F SINGLE SHETH CENTRAL-TUBE
ARMOURED OPTICAL FIBRE CABLE**



Applications

- In areas where high mechanical load is required
- Suitable in area of rodent menace
- Direct burial & Inside duct - PE Outer Sheath
- Inside duct - FR PVC / HFFR / LSZH Outer Sheath



Typical Cross section of 24 Fibre

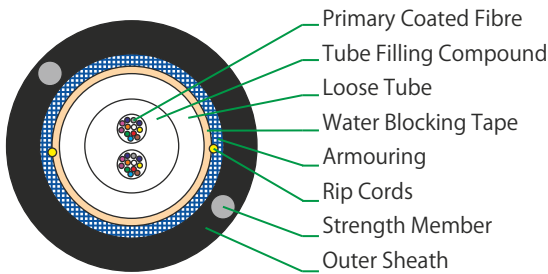

Cable Construction Details

- Up to 48 enhanced low water peak single mode fibres in full compliance with ITU-T-G.652.D (also available with G655 / G656 / G657 SM Fibre and OM1 / OM2 / OM3 & OM4 MM Fibre)
- Metallic anti-buckling steel rod as strength member. Embedded in outer sheath (also available with non metallic strength member FRP rod)
- Loose buffer tubes fully filled with Thixotropic Jelly and Fibres centrally place in the cable
- Water blocking tape wrapping
- Electrolyte chrome plated, corrugated steel tape armoured
- UV Stablized PE Outer sheath, black (also available with FR PVC & HFFR)

Technical Characteristics

FIBRE COUNT	DIAMETER (mm) Nominal	WEIGHT (Kg./Km) Nominal	TENSILE STRENGTH (N)		BENDING RADIUS (mm)		TEMPERATURE RANGE (IEC 60794-1-2-F1)	
			Installation	Operation	Installation	Operation	Installation	Operation
12F	8.0	80	2000	1000	10D	20D	-10° to +50° C	-40° to +70° C
24F	8,5	85	2000	1000	10D	20D	-10° to +50° C	-40° to +70° C

Colour Coding - Fibre



* For Fibre count more than 12F, bundles in multiple of 12F will be formed with color identification binder (Blue, Orange, Green & Brown)

Special Features

- Lighter weight cable for faster and easier installation
- Robust construction.
- Corrugated steel tape acts as protection against rodents and mechanical protection

Drum Length

2000/4000meters ± 5%

Mechanical Characteristics

Repeated Bending (IEC 60794-1-2-E6)	30 Cycle, r= 20 X D, 5 Kg Load, D = Cable Diameter
Torsion Resistance (IEC 60794-1-2-E7)	10 Cycle (± 360°) 5 Kg Weight, L= 2 Mtr
Crush Resistance (IEC 60794-1-2-E3)	1000 N (100 X 100mm) for 600 sec
Impact Resistance (IEC 60794-1-2-E4)	5 Nm, 3 Nos
Kink Resistance (IEC 60794-1-2-E10)	10 x D, D = Cable Diameter
Water Penetration (IEC 60794-1-2-F5B)	1 Mtr Water Head, 3 Meter Cable Sample, 24 Hours

**12F-288F SINGLE SHEATH MULTI-TUBE
ARMoured OPTICAL FIBRE CABLE**



Applications

- In areas where high mechanical load is required
- Suitable in area of rodent menace
- Direct burial & Inside duct - PE Outer Sheath
- Inside duct - FR PVC / HFFR / LSZH Outer Sheath

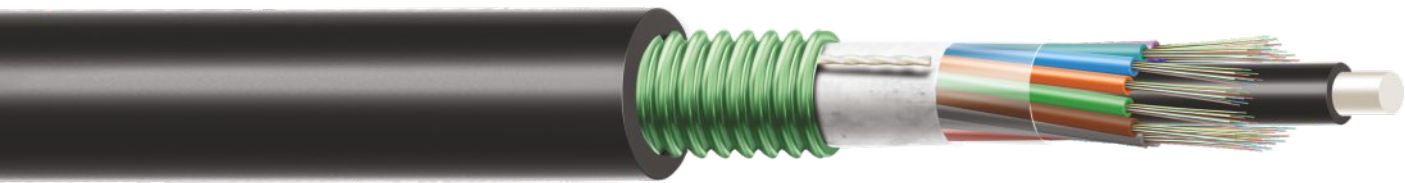

Typical Cross section of 72 Fibre

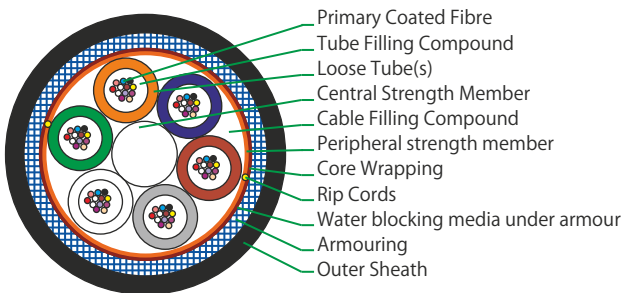

Cable Construction Details

- Up to 288 enhance low water peak single mode fibres in full compliance with ITU-T-G.652.D (also available with G655 / G656 / G657 SM Fibre and OM1 / OM2 / OM3 & OM4 MM Fibre)
- 2/4/6/8/12/24/ fibre per tube combinations are available in 6/8/12/18/24 element construction
- Loose buffer tubes fully filled with Thixotropic Jelly and Fibres
- Non metallic anti-buckling FRP rod used as Central Strength Member. (also available with metallic strength member)
- Cable core is dry (also available in Jelly filled)
- S-Z core wrapped with polyester tape / water swellable tape)
- Electrolytic chrome plated & Corrugated steel tape armouring
- UV Stabilized HDPE outer sheath, black (also available with FR PVC & HFFR)

Technical Characteristics

FIBRE COUNT	DIAMETER (mm) Nominal	WEIGHT (Kg./Km) Nominal	TENSILE STRENGTH (N)		BENDING RADIUS (mm)		TEMPERATURE RANGE (IEC 60794-1-2-F1)	
			Installation	Operation	Installation	Operation	Installation	Operation
UPTO 72F	11.5	120	3000	1800	10D	20D	-10° to +50° C	-40° to +70° C
96F	12.8	155	5600	3200	10D	20D	-10° to +50° C	-40° to +70° C
144F	15.5	220	6500	3800	10D	20D	-10° to +50° C	-40° to +70° C
192F-216F	16	220	4800	2600	10D	20D	-10° to +50° C	-40° to +70° C
288F	18	280	6000	3400	10D	20D	-10° to +50° C	-40° to +70° C

Colour Coding - Fibre & Tube



Special Features

- Single layer S-Z stranded construction
- Corrugated steel tape acts as protection against rodents and mechanical damage.
- Robust construction
- Flexible buffer tubes provide easy fibre routing inside closure

Mechanical Characteristics

Repeated Bending (IEC 60794-1-2-E6)	30 Cycle, r= 20 X D, 5 Kg Load, D = Cable Diameter
Torsion Resistance (IEC 60794-1-2-E7)	10 Cycle (± 360°) 5 Kg Weight, L= 2 Mtr
Crush Resistance (IEC 60794-1-2-E3)	2000 N (100 X 100 mm) for 600 sec
Impact Resistance (IEC 60794-1-2-E4)	10 Nm, 3 Nos
Kink Resistance (IEC 60794-1-2-E10)	10 x D, D = Cable Diameter
Water Penetration (IEC 60794-1-2-F5B)	1 Mtr Water Head, 3 Meter Cable Sample, 24 Hours

Drum Length

2000/ 4000meters ± 5%

12F-288F DOUBLE SHEATH MULTI-TUBE ARMoured OPTICAL FIBRE CABLE



Applications

- In areas where high mechanical load is required
- Suitable in area of rodent menace
- Direct burial & Inside duct - PE Outer Sheath
- Inside duct - FR PVC / HFFR / LSZH Outer Sheath



Typical Cross section of 72 Fibre

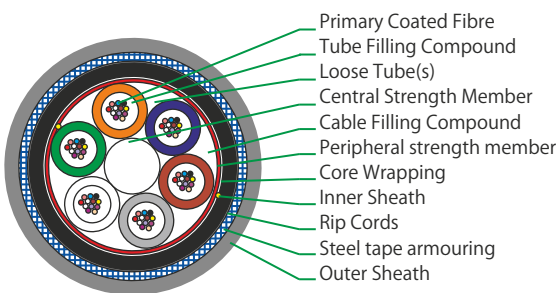

Cable Construction Details

- Up to 288 enhance low water peak single mode fibres in full compliance with ITU-T-G.652.D (also available with G655 / G656 / G657 SM Fibre and OM1 / OM2 / OM3 & OM4 MM Fibre)
- 2/4/6/8/12/24/ fibre per tube combinations are available in 6/8/12/18/24 element construction
- Non metallic anti-buckling FRP rod as Central Strength Member (also available with metallic strength member) Loose buffer tubes fully filled with Thixotropic Jelly and Fibres
- Cable core is dry (also available in Jelly filled)
- S-Z core wrapped with polyester tape / water swellable tape
- Electrolytic chrome plated & Corrugated steel tape armouring
- UV Stabilized HDPE outer sheath, black (also available with FR PVC & HFFR)

Technical Characteristics

FIBRE COUNT	DIAMETER (mm) Nominal	WEIGHT (Kg./Km) Nominal	TENSILE STRENGTH (N)		BENDING RADIUS (mm)		TEMPERATURE RANGE (IEC 60794-1-2-F1)	
			Installation	Operation	Installation	Operation	Installation	Operation
UPTO 72F	13.5	160	3200	1800	10D	20D	-10° to +50° C	-40° to +70° C
96F	15	200	6200	3600	10D	20D	-10° to +50° C	-40° to +70° C
144F	17.8	250	6200	3600	10D	20D	-10° to +50° C	-40° to +70° C
192F-216F	18.5	280	5200	2600	10D	20D	-10° to +50° C	-40° to +70° C
288F	20.5	345	6400	3600	10D	20D	-10° to +50° C	-40° to +70° C

Colour Coding - Fibre & Tube



Special Features

- Single layer S-Z stranded construction
- Corrugated steel tape acts as protection against rodents and mechanical damage.
- Robust construction
- Flexible buffer tubes provide easy fibre routing inside closure

Drum Length

2000/ 4000meters ± 5%

Mechanical Characteristics

Repeated Bending (IEC 60794-1-2-E6)	30 Cycle, r= 20 X D, 10 Kg Load, D = Cable Diameter
Torsion Resistance (IEC 60794-1-2-E7)	10 Cycle (± 360°) 10 Kg Weight, L= 2 Mtr
Crush Resistance (IEC 60794-1-2-E3)	4000 N (100 X 100 mm) for 600 sec
Impact Resistance (IEC 60794-1-2-E4)	10 Nm, 3 Nos
Kink Resistance (IEC 60794-1-2-E10)	10 x D, D = Cable Diameter
Water Penetration (IEC 60794-1-2-F5B)	1 Mtr Water Head, 3 Meter Cable Sample, 24 Hours

2F - 24F SINGLE SHEATH UNITUBE ALL DI-ELECTRIC SELF SUPPORTING AERIAL OPTICAL FIBRE CABLE



Applications

Suitable for self-supporting aerial & duct installation.



Typical Cross section of 12 Fibre

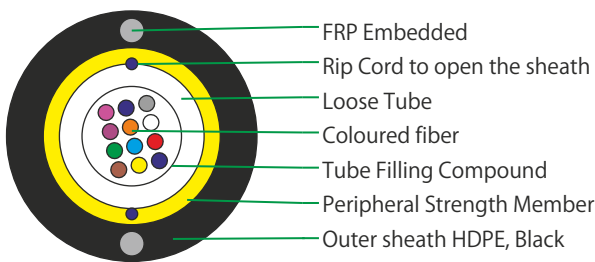

Cable Construction Details

- Up to 24 enhance low water peak single mode fibres in full compliance with ITU-T-G.652.D (also available with G655 / G656 / G657 SM Fibre and OM1 / OM2 / OM3 & OM4 MM Fibre).
- Loose buffer tubes fully filled with Thixotropic Jelly & Fibres.
- Aramid yarn used as peripheral strength member.
- UV Stabilized PE outer sheath, Black (also available with HFFR / FRPVC).
- 2 (Nom) FRP Embedded in outer sheath.
- Rip cord to open the sheath.

Technical Characteristics

FIBRE COUNT	DIAMETER (mm) Nominal	WEIGHT (Kg./Km) Nominal	TENSILE STRENGTH (N)		BENDING RADIUS (mm)		TEMPERATURE RANGE (IEC 60794-1-2-F1)	
			Installation	Operation	Installation	Operation	Installation	Operation
2	6.5	36	1000	450	15D	20D	-10°C to +50°C	-40°C to +70°C
4	6.5	36	1000	450	15D	20D	-10°C to +50°C	-40°C to +70°C
6	6.5	36	1000	450	15D	20D	-10°C to +50°C	-40°C to +70°C
8	6.5	36	1000	450	15D	20D	-10°C to +50°C	-40°C to +70°C
12	6.5	36	1000	450	15D	20D	-10°C to +50°C	-40°C to +70°C
24	7.0	40	1000	450	15D	20D	-10°C to +50°C	-40°C to +70°C

Fibre & Tube color coding

Without ring mark



With ring mark



*More than 12 fibre we provide black Ring mark above the coloured fibre.

Special Features

- Central Loose tube construction
- Offers exceptional strength and corrosion resistance for aerial application
- Flexible buffer tubes provide easy fibre routing inside closure

Drum Length

2000/ 4000meters ± 5%

Mechanical Characteristics

Cable Bending Radius (mm) [IEC 60794-1-21-E11 A & B]	20 X D, D= Cable diameter
Impact Resistance (Nm) [IEC 60794-1-21-E4]	3 Nm, 3 Impacts
Crush Resistance (N) [IEC 60794-1-21-E3]	1000 N (100 X 100 mm)
Torsion Resistance [IEC 60794-1-21-E7]	10 Cycle (± 180°)

12F - 288F SINGLE SHEATH MULTI TUBE DI ELECTRIC RODENT PROTECTED FIBRE OPTIC CABLE - GLASS YARN



Applications

- Suitable for Duct Installation, pulled & blown



Typical Cross section of 96 Fibre

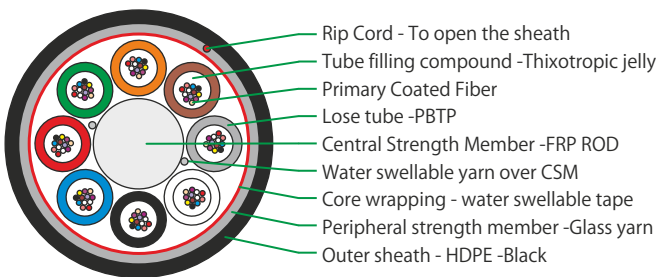

Cable Construction Details

- Up to 288 enhance low water peak single mode fibres in full compliance with ITU-T-G.652.D (also available with G655 / G656 / G657 SM Fibre and OM1 / OM2 / OM3 & OM4 MM Fibre).
- 6/8/12 fibre per tube combinations are available in 5/6/8/12/18/24/36 element constructions.
- Non metallic anti-buckling FRP rod as Central Strength Member.
- Loose buffer tubes fully filled with Thixotropic Jelly & Fibers.
- Loose buffer tubes S-Z Stranded (Water Swellable Yarn over CSM).
- Cable core is Dry & wrapped with water swellable tape.
- Glass yarn used as peripheral strength member.
- UV Stabilized PE outer sheath, Black (also available with FR PVC & HFFR).
- Rip cord to open the sheath

Technical Characteristics

FIBRE COUNT	DIAMETER (mm) Nominal	WEIGHT (Kg./Km) Nominal	TENSILE STRENGTH (N)		BENDING RADIUS (mm)		TEMPERATURE RANGE (IEC 60794-1-2-F1)	
			Installation	Operation	Installation	Operation	Installation	Operation
12	10.5	85	3000	1800	10D	20D	-10°C to +50°C	-40°C to +70°C
24	10.5	85	3000	1800	10D	20D	-10°C to +50°C	-40°C to +70°C
36	10.5	85	3000	1800	10D	20D	-10°C to +50°C	-40°C to +70°C
48	10.5	85	3000	1800	10D	20D	-10°C to +50°C	-40°C to +70°C
72	10.5	85	3000	1800	10D	20D	-10°C to +50°C	-40°C to +70°C
96	11.8	115	5800	3400	10D	20D	-10°C to +50°C	-40°C to +70°C
144	14.5	165	6200	3600	10D	20D	-10°C to +50°C	-40°C to +70°C
192	15.0	165	4800	2600	10D	20D	-10°C to +50°C	-40°C to +70°C
216	15.0	165	4800	2600	10D	20D	-10°C to +50°C	-40°C to +70°C
288	17.0	215	5600	3200	10D	20D	-10°C to +50°C	-40°C to +70°C

Color Coding - Fibre & Tube



*More than 12 Tube we provide black stripe above the colored tube

Special Features

- Single Double & Triple layer S-Z stranded construction
- Flexible buffer tubes provide easy fibre routing inside closure
- Light in weight, hence easy to install

Drum Length

2000/ 4000 meters ± 5%

Mechanical Characteristics

Cable Bending Radius (mm) [IEC 60794-1-21-E11 A & B]	20 X D, D= Cable diameter
Impact Resistance (Nm) [IEC 60794-1-21-E4]	5 Nm, 3 Impacts
Crush Resistance (N) [IEC 60794-1-21-E3]	2000 N (100 X 100 mm)
Torsion Resistance [IEC 60794-1-21-E7]	10 Cycle (± 180°)
Water Penetration [IEC 60794-1-22-F5 B]	1 Meter Water Head, 3 Meters Cable Sample, 24 Hours

12F-288F DOUBLE SHEATH MULTI-TUBE DI-ELECTRIC RODENT PROTECTED OPTICAL FIBRE CABLE



Applications

- Direct burial / Inside Duct
- In areas with particularly high mechanical loads
- In areas with rodents



Typical Cross Section of 72F

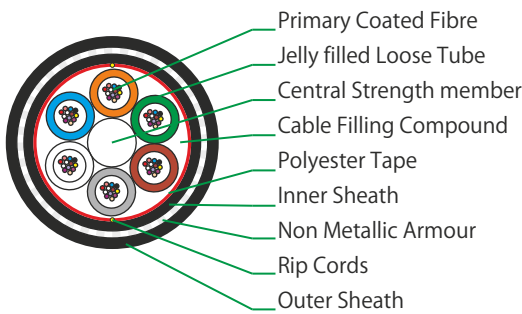

Cable Construction Details

- Upto 144 enhance low water peak single mode fibers in full compliance with ITU-T-G.652.D (also available with G655 / G656 / G657 SM Fibre and OM1 / OM2 / OM3 & OM4 MM Fibre)
- 6/8/12/24/ fibre per tube combinations are available in 6/8/12/18/24 element constructionn
- Non-metallic and anti-buckling element FRP rod used as Central Strength Member.
- Loose buffer tubes fully filled Thixotropic Jelly
- Loose buffer tubes S-Z Stranded
- Cable core is fully filled with Thixotropic Jelly (also available in dry core design)
- Cable core is wrapped with Polyester Tape / Water swellable tape
- UV Stabilized PE inner sheath, Black
- Glass Yarns used as dielectric armour
- UV Stabilized PE outer sheath, Black
- Rip to open the sheath

MULTI TUBE DESIGN

FIBRE COUNT	DIAMETER (mm) Nominal	WEIGHT (Kg./Km) Nominal	TENSILE STRENGTH (N)		BENDING RADIUS (mm)		TEMPERATURE RANGE (IEC 60794-1-2-F1)	
			Installation	Operation	Installation	Operation	Installation	Operation
UPTO 72F	12.5	120	3600	2000	10D	20D	-10° to +50° C	-40° to +70° C
96F	13.8	150	6500	3800	10D	20D	-10° to +50° C	-40° to +70° C
144F	16.5	210	7000	4200	10D	20D	-10° to +50° C	-40° to +70° C
192F-216F	17.0	210	5400	2800	10D	20D	-10° to +50° C	-40° to +70° C
288F	19.0	270	6500	3800	10D	20D	-10° to +50° C	-40° to +70° C

Colour Coding - Fibre & Tube



Special Features

- Single layer stranded construction
- Particularly robust cable
- Flexible buffer tubes provide easy fibre routing inside closure
- All dielectric armoured

Mechanical Characteristics

Repeated Bending [IEC 60794-1-2-E6]	30 Cycle, r= 20 X D, 10 Kg Load, D = Cable D
Torsion Resistance [IEC 60794-1-2-E7]	10 Cycle (± 360°) 10 Kg Weight, L= 2 Mtr
Crush Resistance [IEC 60794-1-2-E3]	3000 N / (100 X 100 mm) for 60 sec
Impact Resistance [IEC 60794-1-2-E4]	Height 500 mm, Weight = 5 Kg, 3 Nos
Kink Resistance [IEC 60794-1-2-E10]	10 x D, D = Cable D
Water Penetration [IEC 60794-1-2-F5B]	1 Mtr Water Head, 3 Meter Cable Sample, 24 Hours

4F-24F DOUBLE SHEATH UNI-TUBE UNDERGROUND STEEL WIRE ARMoured OPTICAL FIBRE CABLE

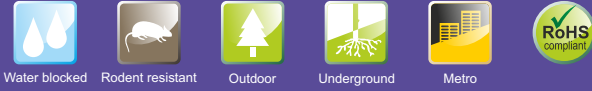

Applications

- Suitable for Duct/direct buried Application



Typical Cross section of 24 Fibre

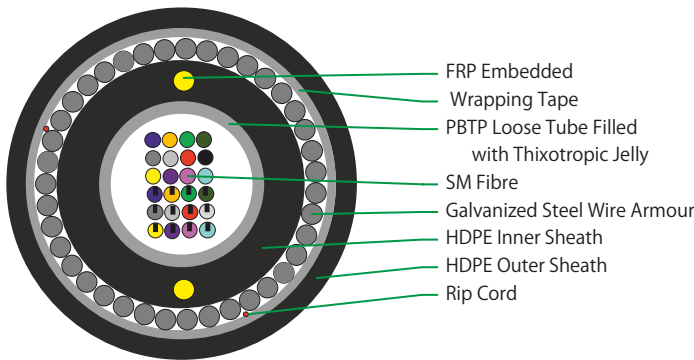

Cable Construction Details

- Non-metallic and anti-buckling element FRP rod used at inner sheath
- Loose buffer tubes fully filled
- HDPE Inner sheath, Black Colour
- Galvanized Steel Wire Armour over Inner Sheath
- UV Stabilized, HDPE Outer sheath, Black Colour

Technical Characteristics

FIBRE COUNT	DIAMETER (mm) Nominal	WEIGHT (Kg./Km) Nominal	TENSILE STRENGTH (N)		BENDING RADIUS (mm)		TEMPERATURE RANGE (IEC 60794-1-2-F1)	
			Installation	Operation	Installation	Operation	Installation	Operation
4F	12.0	210	2500	1500	15D	25D	-20 °C to +70 °C	-20 °C to +70 °C
6F	12.0	210	2500	1500	15D	25D	-20 °C to +70 °C	-20 °C to +70 °C
8F	12.0	210	2500	1500	15D	25D	-20 °C to +70 °C	-20 °C to +70 °C
12F	12.2	215	2500	1500	15D	25D	-20 °C to +70 °C	-20 °C to +70 °C
24F	12.5	220	2500	1500	15D	25D	-20 °C to +70 °C	-20 °C to +70 °C

Fibre & Tube Colour Coding



For Fibre Count 12F We provide the above colour code
For Higher Fibre count We provide contrast dot marking of above colour code

Special Features

- Galvanized Steel wire amour provided excellent Crush & Impact Resistance.
- Flexible buffer tubes provide easy fibre routing inside closure.
- The Metallic Armour enables post installation cable locating.

Drum Length

2000/ 4000 meters ± 5%

Mechanical Characteristics

Kink Resistance (mm) [IEC 60794-1-2-E10]	15 x D, D = Cable Diameter
Impact Resistance (Nm) [IEC 60794-1-2-E4]	Height 0.5 meters, Weight = 5 Kg, 3 Nos
Crush Resistance (N) [IEC 60794-1-2-E3]	4000 N [100 X 100 mm] for 60 sec
Repeated Bending [IEC 60794-1-2-E6]	10 Cycle, r = 20 X D, 5 Kg Load, D = Cable Diameter
Water Penetration [IEC 60794-1-2-F5 B]	1 Meter Water Head, 3 Meters Cable Sample, 24 Hours [On Inner Sheath]

12F-144F DOUBLE SHEATH MULTI-TUBE STEEL WIRE ARMoured OPTICAL FIBRE CABLE



Applications

- In areas where high pulling force is required
- In areas where complex cable run is required
- Direct burial & Inside duct - PE Outer Sheath
- Inside duct - FR PVC / HFFR / LSZH Outer Sheath

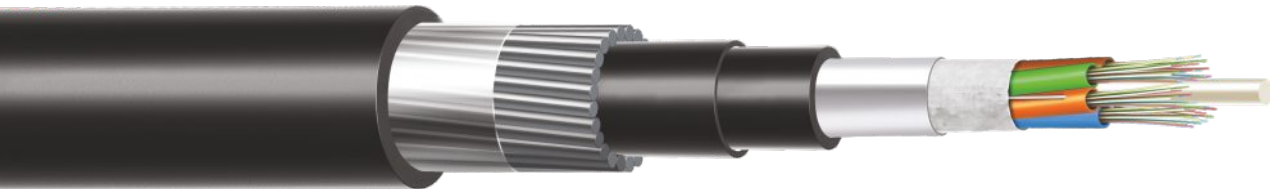

Typical Cross section of 48 Fibre

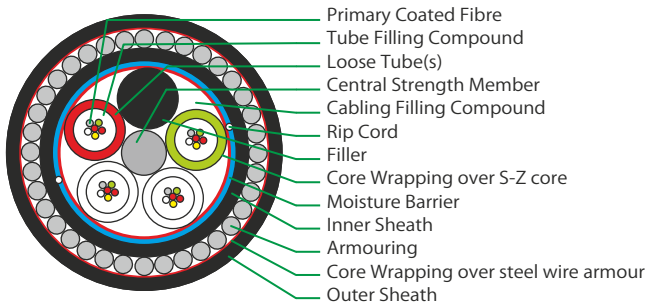

Cable Construction Details

- Up to 144 enhance low water peak single mode fibres in full compliance with ITU-T-G.652.D (also available with G655 / G656 / G657 SM Fibre and OM1 / OM2 / OM3 & OM4 MM Fibre)
- Phosphate coated metallic anti-buckling steel rod as central strength member (also available with non metallic strength member, FRP rod)
- 2/4/6/8/12 fibre per tube combinations are available in 5/6/8/12 element constructions
- Loose buffer tubes fully filled S-Z Stranded
- Cable core fully filled with jelly
- PE coated Aluminium foil as moisture barrier
- UV Stabilized PE inner sheath, black
- Galvanised Steel wire armour, wrapped with polyester tape
- UV stabilized HDPE outer sheath, black (also available with FR PVC & HFFR)

Technical Characteristics

FIBRE COUNT	DIAMETER (mm) Nominal	WEIGHT (Kg./Km) Nominal	TENSILE STRENGTH (N)		BENDING RADIUS (mm)		TEMPERATURE RANGE (IEC 60794-1-2-F1)	
			Installation	Operation	Installation	Operation	Installation	Operation
UPTO 60F	14.5	350	6000	3000	15D	20D	-10° to +50°C	-40° to +70°C
72F	15.0	375	6000	3000	15D	20D	-10° to +50°C	-40° to +70°C
96F	17.0	425	6000	3000	15D	20D	-10° to +50°C	-40° to +70°C
144F	18.7	520	10000	5000	15D	20D	-10° to +50°C	-40° to +70°C

Colour Coding - Fibre & Tube



Special Features

- Single layer S-Z stranded construction.
- Phosphate coating over steel wire CSM prevent Hydrogen generation.
- Aluminium Foils provides excellent protection against Moisture.
- Rugged & robust design

Drum Length

2000 meters ± 5%

Mechanical Characteristics

Repeated Bending (IEC 60794-1-2-E6)	30 Cycle, 20 X D, 10 Kg Load, D = Cable D
Crush Resistance (IEC 60794-1-2-E3)	6000 N (100 X 100 mm) for 600 sec
Impact Resistance (IEC 60794-1-2-E4)	Height 500 mm, Weight = 5 Kg, 10 Nos at Different Place
Kink Resistance (IEC 60794-1-2-E10)	20 x D, D = Cable D
Water Penetration (IEC 60794-1-2-F5)	1 Mtr Water Head, 3 Meter Cable Sample, 24 Hours

12F - 144F TRIPLE SHEATH MULTI-TUBE SINGLE MODE WIRE ARMoured FIBRE OPTIC CABLE

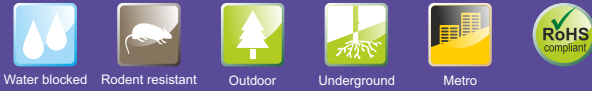

Applications

- Suitable for Duct/Direct Buried Application



Typical Cross section of 144 Fibre

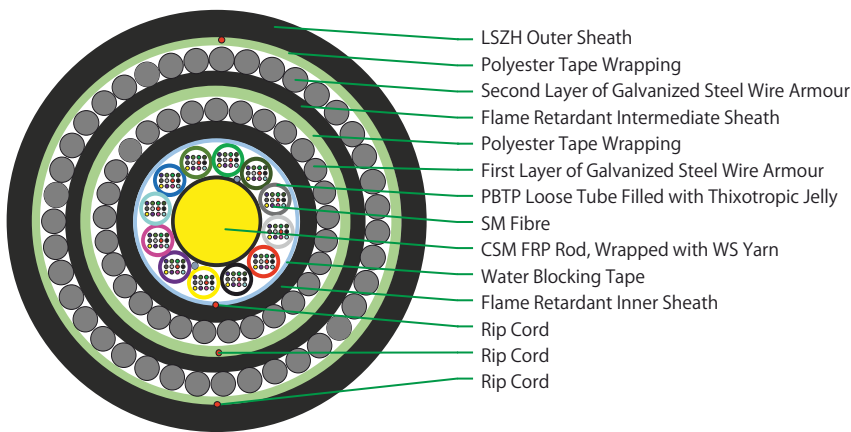

Cable Construction Details

- 1. Non-metallic and anti-buckling element FRP rod used as Central Strength Member
- Loose buffer tubes fully filled
- Loose buffer tubes S-Z Stranded
- S-Z core is dry type filled with water swellable yarn & tape
- HDPE Black Inner sheath, black colour
- Galvanized Steel Wire Armour over Inner Sheath
- HDPE Black Intermediate sheath, black colour
- Galvanized Steel Wire Armour over Intermediate Sheath
- HDPE Black Colour Outer sheath UV Stabilized

Technical Characteristics

FIBRE COUNT	DIAMETER (mm) Nominal	WEIGHT (Kg./Km) Nominal	TENSILE STRENGTH (N)		BENDING RADIUS (mm)		TEMPERATURE RANGE (IEC 60794-1-2-F1)	
			Installation	Operation	Installation	Operation	Installation	Operation
12	18.5	625	2000	3000	25D	40D	-10°C to +70°C	-20°C to +70°C
24	18.5	625	2000	3000	25D	40D	-10°C to +70°C	-20°C to +70°C
36	18.5	625	2000	3000	25D	40D	-10°C to +70°C	-20°C to +70°C
48	18.5	625	2000	3000	25D	40D	-10°C to +70°C	-20°C to +70°C
72	18.5	625	2000	3000	25D	40D	-10°C to +70°C	-20°C to +70°C
96	20.0	765	2000	3000	25D	40D	-10°C to +70°C	-20°C to +70°C
144	23.0	980	2000	3000	25D	40D	-20°C to +70°C	-20°C to +70°C

Fibre & Tube Colour Coding



For Fibre Count 12F We provide the above colour code
For Higher Fibre count We provide contrast dot marking of above colour code

Special Features

- Single layer stranded construction
- Double Layer of Galvanized Steel wire armour provided excellent Crush & Impact Resistance
- Flexible buffer tubes provide easy fibre routing inside closure

Drum Length

2000/ 4000 meters ± 5%

Mechanical Characteristics

- Kink Resistance (mm) [IEC 60794-1-2-E10] 25 x D, D = Cable Diameter
- Impact Resistance (Nm) [IEC 60794-1-2-E4] Height 0.5 meters, Weight = 5 Kg, 3 Nos
- Crush Resistance (N) [IEC 60794-1-2-E3] 4000 N [100 X 100 mm] for 60 sec
- Water Penetration [IEC 60794-1-2-F5 B] 1 Meter Water Head, 3 Meters Cable Sample, 24 Hours [On Inner Sheath]

12F-144F DOUBLE SHEATH MULTI-TUBE FRP ROD ARMoured OPTICAL FIBRE CABLE



Applications

- In areas where high pulling force is required
- In areas where complex cable run is required
- Direct burial & Inside duct - PE Outer Sheath
- Inside duct - FR PVC / HFFR / LSZH Outer Sheath



Typical Cross section of 72 Fibre

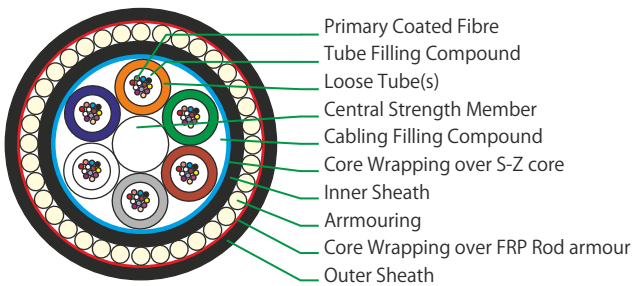

Cable Construction Details

- Up to 144 enhance low water peak single mode fibres in full compliance with ITU-T-G.652.D (also available with G655 / G656 / G657 SM Fibre and OM1 / OM2 / OM3 & OM4 MM Fibre)
- 6/8/12/24/ fibre per tube combinations are available in 6/8/12/18/24 element construction
- Non-metallic anti-buckling FRP rod as Central Strength Member.
- Loose buffer tubes fully filled, S-Z Stranded
- Cable core is fully filled with Thixotropic Jelly (also available in dry core design)
- Cable core is wrapped with Polyester Tape and water swellable tape
- UV Stabilized PE inner sheath, black
- FRP rods for armouring
- UV stabilized PE outer sheath, black (also available with FR PVC & HFFR)

Technical Characteristics

FIBRE COUNT	DIAMETER (mm) Nominal	WEIGHT (Kg./Km) Nominal	TENSILE STRENGTH (N)		BENDING RADIUS (mm)		TEMPERATURE RANGE (IEC 60794-1-2-F1)	
			Installation	Operation	Installation	Operation	Installation	Operation
UPTO 48F	14.0	180	5000	2500	15D	20D	-10° to +50°C	-40° to +70°C
72F	15.0	210	5000	2500	15D	20D	-10° to +50°C	-40° to +70°C
96F	16.5	240	5000	2500	15D	20D	-10° to +50°C	-40° to +70°C
144F	19.5	340	5000	2500	15D	20D	-10° to +50°C	-40° to +70°C

Colour Coding - Fibre & Tube



Special Features

- Single layer S-Z stranded construction.
- Completely dielectric construction
- Rugged & robust design

Mechanical Characteristics

Repeated Bending [IEC 60794-1-2-E6]	30 Cycle, 20 X D, 10 Kg Load D = Cable D
Torsion Resistance [IEC 60794-1-2-E7]	10 Cycle (± 360°) 5 Kg Weight, L= 2 Mtr
Crush Resistance [IEC 60794-1-2-E3]	3000 N (100 X 100 mm) for 600 sec
Impact Resistance [IEC 60794-1-2-E4]	Height 500 mm, Weight = 5 Kg, 10 Nos at Different Place
Kink Resistance [IEC 60794-1-2-E10]	20 x D, D = Cable D
Water Penetration [IEC 60794-1-2-F5]	1 Mtr Water Head, 3 Meter Cable Sample, 24 Hours

Drum Length

2000/ 4000 meters ± 5%

12F -288F TRIPLE SHEATH MULTI-TUBE SINGLE MODE FRP ARMOURED FIBRE OPTIC CABLE

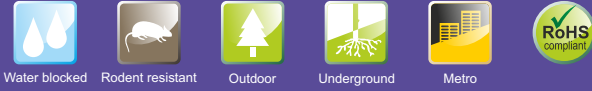

Applications

- Suitable for Duct/Direct Buried Application
- The universal design is suited for use in most network arenas, including backbone, access and distribution
- Installation within Duct using blown on pulling techniques

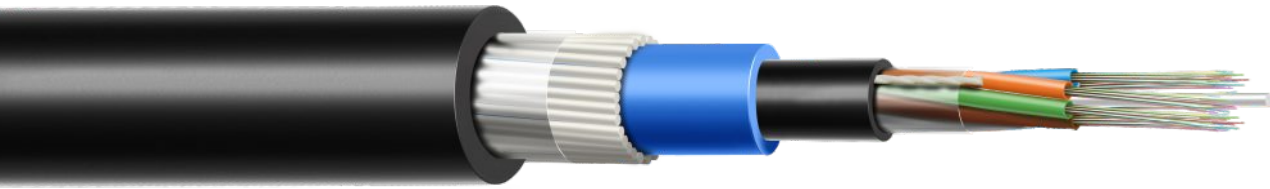

Typical Cross section of 144 Fibre

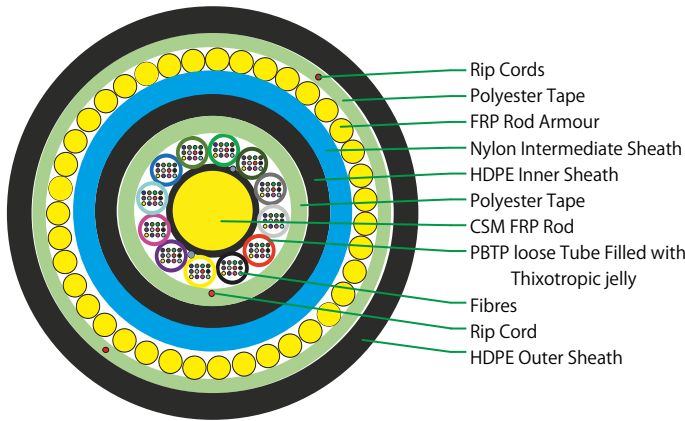

Cable Construction Details

- Non-metallic and anti-buckling element FRP rod used as Central Strength Member
- Loose buffer tubes fully filled
- Loose buffer tubes S-Z Stranded
- S-Z core is filled with Thixotropic Jelly
- UV Stabilized PE Inner Sheath, Black Colour
- Insect Resistance Intermediate Sheath of Nylon Jacket over Inner Sheath, Blue Colour
- FRP Rod Armouring
- UV Stabilized, HDPE Outer Sheath, Black Colour

Technical Characteristics

FIBRE COUNT	DIAMETER (mm) Nominal	WEIGHT (Kg./Km) Nominal	TENSILE STRENGTH (N)		BENDING RADIUS (mm)		TEMPERATURE RANGE (IEC 60794-1-2-F1)	
			Installation	Operation	Installation	Operation	Installation	Operation
12	15.0	180	4000	2000	10D	20D	-20°C to +70°C	-20°C to +70°C
24	15.0	180	4000	2000	10D	20D	-20°C to +70°C	-20°C to +70°C
36	15.0	180	4000	2000	10D	20D	-20°C to +70°C	-20°C to +70°C
48	15.0	180	4000	2000	10D	20D	-20°C to +70°C	-20°C to +70°C
72	15.0	180	4000	2000	10D	20D	-20°C to +70°C	-20°C to +70°C
96	16.5	225	4000	2000	10D	20D	-20°C to +70°C	-20°C to +70°C
144	19.0	300	4000	2000	10D	20D	-20°C to +70°C	-20°C to +70°C
288(12f per tube)	22.0	400	4000	2000	10D	20D	-20°C to +70°C	-20°C to +70°C
288(24f per tube)	21.0	375	4000	2000	10D	20D	-20°C to +70°C	-20°C to +70°C

Fibre colour coding



For Fiber Count 12F We provide the above color code
For Higher Fiber count We provide contrast dot marking of above color code

Special Features

- Single/Double layer stranded construction
- Flexible buffer tubes provide easy fibre routing inside closure
- FRP Armour provides better Crush Resistance
- Requires no grounding or bonding due to all-dielectric construction

Drum Length

2000/ 4000 meters ± 5%

Mechanical Characteristics

- Kink Resistance (mm) [IEC 60794-1-2-E10] 10 x D, D = Cable Diameter
- Repeated Bending [IEC 60794-1-2-E6] 30 Cycle, r = 20 X D, 5 Kg Load, D = Cable Diameter
- Impact Resistance (Nm) [IEC 60794-1-2-E4] 2 J, 3 Impacts
- Crush Resistance (N) [IEC 60794-1-2-E3] Short Term: 4000 N [100 X 100 mm] for 60 sec & Long Term: 2000 N [100 X 100 mm] for 120 sec
- Water Penetration [IEC 60794-1-2-F5 B] 1 Meter Water Head, 3 Meters Cable Sample, 24 Hours [On Inner Sheath]

**MULTI-TUBE RIBBON TYPE
CABLE (48-576 F)**

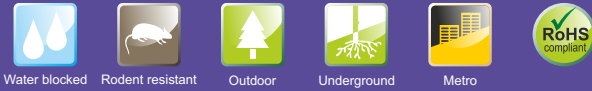

Applications

- Suitable for Duct Installation, pulled & blown



Typical Cross section of 288 Fibre

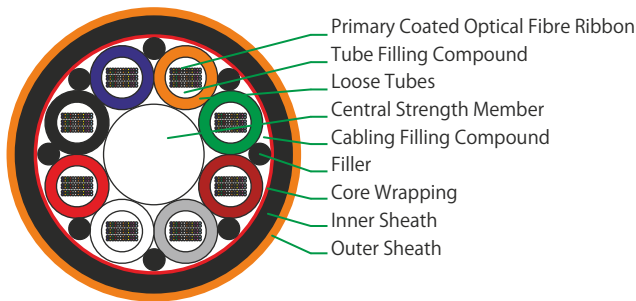

Cable Construction Details

- Up to 576 enhance low water peak single mode fibres in full compliance with ITU-T-G.652.D in 4/8/12 Fibre Ribbon (also available with G655 / G656 / G657 SM Fibre and OM1 / OM2 / OM3 & OM4 MM Fibre)
- Non metallic and anti-buckling FRP rod as Central Strength Member
- Loose buffer tubes fully filled, S-Z Stranded
- Cable core is fully filled with Thixotropic Jelly (also available in dry core design)
- S-Z core wrapped with polyester tape/water swellable tape
- UV Stabilized PE Inner sheath, Black
- Insect & termite resistance PA-12 outer sheath, Orange

Technical Characteristics

FIBRE COUNT	DIAMETER (mm) Nominal	WEIGHT (Kg./Km) Nominal	TENSILE STRENGTH (N)		BENDING RADIUS (mm)		TEMPERATURE RANGE (IEC 60794-1-2-F1)	
			Installation	Operation	Installation	Operation	Installation	Operation
UPTO 96F	19.0	280	3000	1500	15D	20D	-10° to +50°C	-40° to +70°C
144F	20.5	340	3000	1500	15D	20D	-10° to +50°C	-40° to +70°C
288F	24.0	525	3000	1500	15D	20D	-10° to +50°C	-40° to +70°C
576F	30.0	740	3000	1500	15D	20D	-10° to +50°C	-40° to +70°C

Color Coding - Fibre & Tube



* Identification of ribbon in loose tube - 1 ribbon 1, 2 ribbon 2, 3 ribbon 3.....

Special Features

- Single layer S-Z stranded construction
- Flexible buffer tubes provide easy fibre routing inside closure
- Insect & Termite resistant

Drum Length

2000/ 3000/ 4000 meters ± 5%

Mechanical Characteristics

Repeated Bending [IEC 60794-1-2-E6]	30 Cycle, r= 20 X D, 10 Kg Load, D = Cable D
Torsion Resistance [IEC 60794-1-2-E7]	10 Cycle (± 360°) 10 Kg Weight, L= 2 Mtr
Crush Resistance [IEC 60794-1-2-E3]	2500 N (100 X 100 mm) for 600 sec
Impact Resistance [IEC 60794-1-2-E4]	Height 500 mm, Weight = 5 Kg, 3 Nos
Kink Resistance [IEC 60794-1-2-E10]	10 x D, D = Cable D
Water Penetration [IEC 60794-1-2-F5B]	1 Mtr Water Head, 3 Meter Cable Sample, 24 Hours

**144F - 864F SINGLE SHEATH MULTI-TUBE
SINGLE MODE RIBBON ECCS TAPE FIBRE OPTIC CABLE**

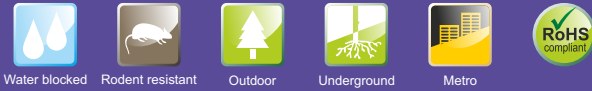

Applications

Suitable for Duct Installation

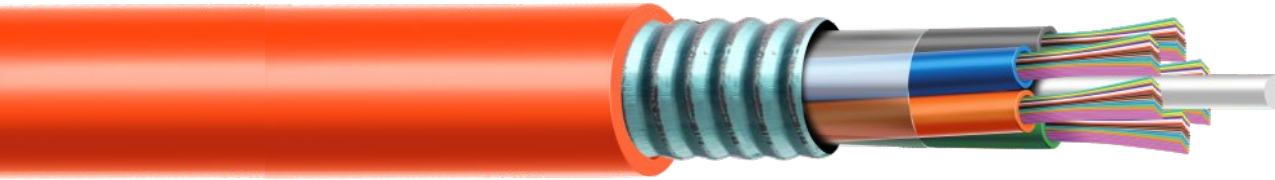

Typical Cross section of 864 Fibre

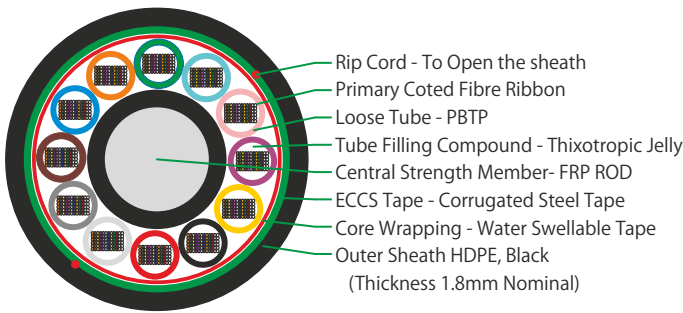

Cable Construction Details

- Enhance low water peak single mode fibers in full compliance with ITU-T-G657A2
- Non-metallic and anti-buckling element FRP rod used as Central Strength Member
- Loose buffer tubes fully filled with Thixotropic Jelly & Ribbon Fibers
- Loose buffer tubes S-Z Stranded
- S-Z core is Dry & Wrapping with Water Swellable tape
- ECCS Tape Armouring.
- UV Stabilized, HDPE Outer sheath, black

Technical Characteristics

FIBRE COUNT	No of Fibre Per Ribbon	No of Ribbon Per Tube	No of Loose Tube	DIAMETER (mm) Nominal	WEIGHT (Kg./Km) Nominal	TENSILE STRENGTH (N)		BENDING RADIUS (mm)		TEMPERATURE RANGE (IEC 60794-1-2-F1)	
						Installation	Operation	Installation	Operation	Installation	Operation
288F	12	6	4	22.5	400	1200	2400	15D	25D	-5 °C to +45 °C	-20 °C to +70 °C
360F	12	6	5	22.5	400	1200	2400	15D	25D	-5 °C to +45 °C	-20 °C to +70 °C
432F	12	6	6	24.5	500	1500	3100	15D	25D	-5 °C to +45 °C	-20 °C to +70 °C
720F	12	10	6	28.0	600	1800	3500	15D	25D	-5 °C to +45 °C	-20 °C to +70 °C
864F	12	12	6	28.0	600	1600	3100	15D	25D	-5 °C to +45 °C	-20 °C to +70 °C

Fibre & Tube colour coding



For Fiber Count 12F We provide the above colour code

Ribbon Coding

Numeric Number Marking at every ≥50 mm on Each Ribbon

Special Features

- Single layer stranded construction.
- Offers exceptional strength for underground application
- Flexible buffer tubes provide easy fibre routing inside closure

Drum Length

2000/ 4000 meters ± 5%

Mechanical Characteristics

- Crush Resistance (N) [IEC 60794-1-2-E3] 2000 N [100 X 100 mm] for 1 minute, Number of Test: 3 at 500 mm apart
- Impact Resistance (Nm) [IEC 60794-1-2-E4] Height 500 mm, Weight = 5.0 Kg, 3 Nos
- Torsion Resistance [IEC 60794-1-2-E7] 10 Cycle (± 180°)
- Water Penetration [IEC 60794-1-22-F5 B/C] 1 Mtr water height 3 Mtr cable Sample, 24 Hrs (Applicable on inner Sheath)

144F - 1728F SINGLE SHEATH MULTI-TUBE SINGLE MODE RIBBON FIBRE OPTIC CABLE

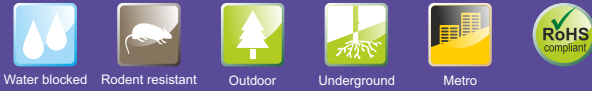

Applications

Suitable for Duct Installation



Typical Cross section of 864 Fibre

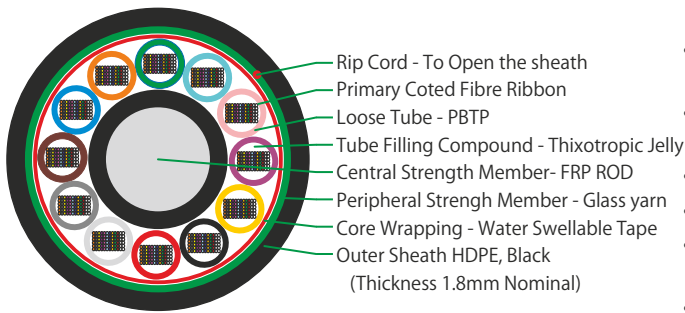

Cable Construction Details

- Enhance low water peak single mode fibers in full compliance with ITU-T-G657A2
- Non-metallic and anti-buckling element FRP rod used as Central Strength Member
- Loose buffer tubes fully filled with Thixotropic Jelly & Ribbon Fibers
- Loose buffer tubes S-Z Stranded
- S-Z core is Dry & Wrapping with Water Swellable tape
- Peripheral Strength Member - Glass Yarn if required to meet Tensile Strength.
- UV Stabilized, HDPE Outer sheath, black

Technical Characteristics

FIBRE COUNT	No of Fibre Per Ribbon	No of Ribbon Per Tube	No of Loose Tube	DIAMETER (mm) Nominal	WEIGHT (Kg./Km) Nominal	TENSILE STRENGTH (N)		BENDING RADIUS (mm)		TEMPERATURE RANGE (IEC 60794-1-2-F1)	
						Installation	Operation	Installation	Operation	Installation	Operation
144F	12	6	2	21.2	320	2200	1100	10D	20D	-5°C to +45°C	-20°C to +70°C
288F	12	6	4	21.2	320	2200	1100	10D	20D	-5°C to +45°C	-20°C to +70°C
432F	12	6	6	23.5	400	2800	1400	10D	20D	-5°C to +45°C	-20°C to +70°C
720F	12	10	6	27.0	500	3000	1400	10D	20D	-5°C to +45°C	-20°C to +70°C
1152F	12	12	8	30.0	630	3200	1400	10D	20D	-5°C to +45°C	-20°C to +70°C
1728F	12	12	12	39.5	1140	4000	1800	10D	20D	-5°C to +45°C	-20°C to +70°C

Fibre & Tube color coding



For Fiber Count 12F We provide the above color code

Ribbon Coding

Numeric Number Marking at every 50 mm on Each Ribbon

Special Features

- Single layer stranded construction.
- Offers exceptional strength for underground application
- Flexible buffer tubes provide easy fibre routing inside closure

Drum Length

2000/ 4000 meters ± 5%

Mechanical Characteristics

- Kink Resistance (mm) [IEC 60794-1-2-E10] 10 x D, D = Cable Diameter
- Crush Resistance (N) [IEC 60794-1-2-E3] 2000 N [100 X 100 mm] for 1 minute, Number of Test: 3 at 500 mm apart
- Impact Resistance (Nm) [IEC 60794-1-2-E4] Height 500 mm, Weight = 5.0 Kg, 3 Nos
- Torsion Resistance [IEC 60794-1-2-E7] 10 Cycle (± 180°)
- Water Penetration [IEC 60794-1-22-F5 B/C] 1 Mtr water height 3 mtr cable Sample, 24 Hrs (Applicable on inner Sheath)

2F- 24F CENTRAL TUBE GLASS YARN ARMoured FIBRE OPTIC CABLE



Applications

Suitable for duct installation



Typical Cross section of 12 Fibre

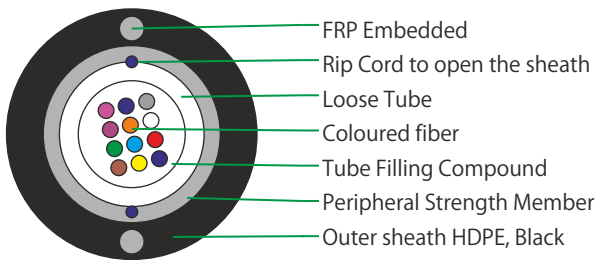

Cable Construction Details

- Up to 24 enhance low water peak single mode fibres in full compliance with ITU-T-G.652.D (also available with G655 / G656 / G657 SM Fibre and OM1 / OM2 / OM3 & OM4 MM Fibre).
- Loose buffer tubes fully filled with Thixotropic Jelly & Fibers.
- Glass yarn used as peripheral strength member.
- UV Stabilized PE outer sheath, Black (also available with HFFR / FR PVC).
- 2 (Nom) FRP Embedded in outer sheath.
- Rip cord to open the sheath.

Technical Characteristics

FIBRE COUNT	DIAMETER (mm) Nominal	WEIGHT (Kg./Km) Nominal	TENSILE STRENGTH (N)		BENDING RADIUS (mm)		TEMPERATURE RANGE (IEC 60794-1-2-F1)	
			Installation	Operation	Installation	Operation	Installation	Operation
2	6.5	36	1000	450	20D	10D	-10°C to +50°C	-40°C to +70°C
4	6.5	36	1000	450	20D	10D	-10°C to +50°C	-40°C to +70°C
6	6.5	36	1000	450	20D	10D	-10°C to +50°C	-40°C to +70°C
8	6.5	36	1000	450	20D	10D	-10°C to +50°C	-40°C to +70°C
12	6.5	36	1000	450	20D	10D	-10°C to +50°C	-40°C to +70°C
24	7.0	40	1000	450	20D	10D	-10°C to +50°C	-40°C to +70°C

Fibre & Tube colour coding

Without ring mark



With ring mark



*More than 12 fibre we provide black Ring mark above the colored fibre.

Special Features

- Central Loose tube construction.
- Lighter weight cable for faster and easier installation.
- Flexible buffer tubes provide easy fibre routing inside closure.

Drum Length

2000/ 4000meters ± 5%

Mechanical Characteristics

Cable Bending Radius (mm) [IEC 60794-1-21-E11 A & B]	20 X D, D= Cable diameter
Impact Resistance (Nm) [IEC 60794-1-21-E4]	3 Nm, 3 Impacts
Crush Resistance (N) [IEC 60794-1-21-E3]	1000 N (100 X 100 mm)
Torsion Resistance [IEC 60794-1-21-E7]	10 Cycle (± 180°)

12F -288F SINGLE SHEATH MULTI TUBE ALL DI-ELECTRIC SELF SUPPORTING OPTICAL FIBRE CABLE



Applications

- Suitable for self supporting aerial installation.
- Suitable for span length of 60 mtrs (also available for other span length)



Typical Cross section of 96 Fibres

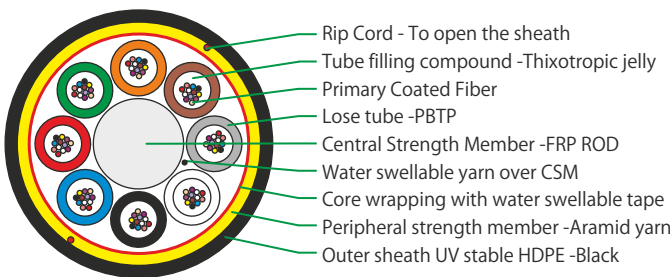

Cable Construction Details

- Up to 288 enhance low water peak single mode fibres in full compliance with ITU-T-G.652.D (also available with G655 / G656 / G657 SM Fibre and OM1 / OM2 / OM3 & OM4 MM Fibre).
- 6/8/12 fibre per tube combinations are available in 6/8/12/18/24 element construction.
- Non metallic anti-buckling FRP rod as Central Strength Member.
- Loose buffer tubes fully filled with Thixotropic Jelly & Fibers.
- Loose buffer tubes S-Z Stranded (Water Swellable Yarn over CSM).
- Cable core is Dry & wrapped with water swellable tape.
- Aramid yarn used as peripheral strength member.
- UV Stabilized PE outer sheath, Black (also available with HFFR / FR PVC).
- Rip cord to open the sheath.

Technical Characteristics

FIBRE COUNT	DIAMETER (mm) Nominal	WEIGHT (Kg./Km) Nominal	TENSILE STRENGTH (N)		BENDING RADIUS (mm)		TEMPERATURE RANGE (IEC 60794-1-2-F1)	
			Installation	Operation	Installation	Operation	Installation	Operation
12	10.5	80	3500	2000	20D	10D	-10°C to +50°C	-40°C to +70°C
24	10.5	80	3500	2000	20D	10D	-10°C to +50°C	-40°C to +70°C
36	10.5	80	3500	2000	20D	10D	-10°C to +50°C	-40°C to +70°C
48	10.5	80	3500	2000	20D	10D	-10°C to +50°C	-40°C to +70°C
72	10.5	80	3500	2000	20D	10D	-10°C to +50°C	-40°C to +70°C
96	11.8	110	6500	3500	20D	10D	-10°C to +50°C	-40°C to +70°C
144	14.5	160	6500	3500	20D	10D	-10°C to +50°C	-40°C to +70°C
192	15.0	160	5000	2500	20D	10D	-10°C to +50°C	-40°C to +70°C
216	15.0	160	5000	2500	20D	10D	-10°C to +50°C	-40°C to +70°C
288	17.0	205	6500	3500	20D	10D	-10°C to +50°C	-40°C to +70°C

Color Coding - Fibre & Tube



*More than 12 Tube we provide black stripe above the colored tube

Special Features

- Single & Double layer S-Z stranded construction.
- Offers exceptional strength and corrosion resistance for aerial application.
- Flexible buffer tubes provide easy fibre routing inside closure.

Drum Length

2000/ 4000 meters ± 5%

Mechanical Characteristics

Cable Bending Radius (mm) [IEC 60794-1-21-E11 A & B]	20 X D, D= Cable diameter
Impact Resistance (Nm) [IEC 60794-1-21-E4]	5 Nm, 3 Impacts
Crush Resistance (N) [IEC 60794-1-21-E3]	2000 N (100 X 100 mm)
Torsion Resistance [IEC 60794-1-21-E7]	10 Cycle (± 180°)
Water Penetration [IEC 60794-1-22-F5 B]	1 Meter Water Head, 3 Meters Cable Sample, 24 Hours

12F-288F DOUBLE SHEATH MULTI-TUBE ALL DI-ELECTRIC SELF SUPPORTING OPTICAL FIBRE CABLE

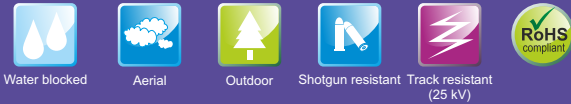

Applications

- Suitable for self supporting aerial installation with rigorous load conditions, including heavy wind and ice
- Suitable for span length of 100 mtrs (also available for other span length)



Typical Cross section of 72 Fibre

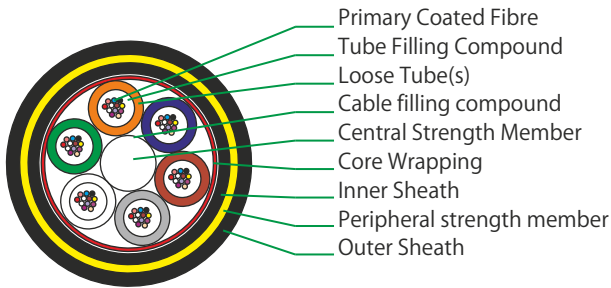

Cable Construction Details

- Up to 288 enhance low water peak single mode fibres in full compliance with ITU-T-G.652.D (also available with G655 / G656 / G657 SM Fibre and OM1 / OM2 / OM3 & OM4 MM Fibre)
- Non metallic anti-buckling FRP rod as Central Strength Member
- Loose buffer tubes fully filled, S-Z Stranded
- Cable core fully filled (also available in dry core design)
- Cable core is wrapped with Polyester Tape/water swellable tape
- UV Stablized PE inner sheath, Black
- High modulus, Aramid yarn peripheral strength member
- UV Stablized PE Outer sheath, Orange

Technical Characteristics

FIBRE COUNT	DIAMETER (mm) Nominal	WEIGHT (Kg./Km) Nominal	TENSILE STRENGTH (N)		BENDING RADIUS (mm)		TEMPERATURE RANGE (IEC 60794-1-2-F1)	
			Installation	Operation	Installation	Operation	Installation	Operation
UPTO 48F	12.5	125	5000	2000	15D	20D	-10 ^o to +50 ^o C	-40 ^o to +70 ^o C
UPTO 72F	13.5	145	5000	2000	15D	20D	-10 ^o to +50 ^o C	-40 ^o to +70 ^o C
96F	15.0	180	5000	2000	15D	20D	-10 ^o to +50 ^o C	-40 ^o to +70 ^o C
144F	18.0	250	5000	2000	15D	20D	-10 ^o to +50 ^o C	-40 ^o to +70 ^o C

Color Coding - Fibre & Tube



Special Features

- Single layer S-Z stranded construction
- Offers exceptional strength and corrosion resistance for aerial application
- Flexible buffer tubes provide easy fibre routing inside closure

Drum Length

2000/ 3000/ 4000 meters ± 5%

Mechanical Characteristics

Repeated Bending (IEC 60794-1-2-E6)	30 Cycle, 20 X D, 5 Kg Load, D = Cable D
Torsion Resistance (IEC 60794-1-2-E7)	10 Cycle (± 180°) 5 Kg Weight, L= 2 Mtr
Crush Resistance (IEC 60794-1-2-E3)	3000 N (100 X 100 mm) for 600 sec
Impact Resistance (IEC 60794-1-2-E4)	Height 500 mm, Weight = 5 Kg, 3 Nos
Kink Resistance (IEC 60794-1-2-E10)	20 x D, D = Cable D
Water Penetration (IEC 60794-1-2-F5)	1 Mtr Water Head, 3 Meter Cable Sample, 24 Hours

2F-24F SINGLE-TUBE FIGURE-8 TYPE AERIAL OPTICAL FIBRE CABLE



Water blocked



Aerial



Outdoor



RoHS compliant

Applications

- Lashed aerial installation with rigorous load conditions, including heavy wind and ice
- Suitable for span length of 100 mtrs



Typical Cross section of 12 Fibre

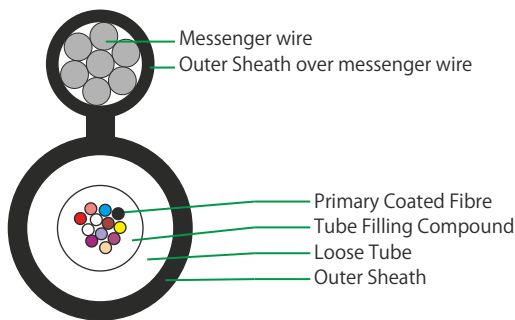

Cable Construction Details

- Upto 24F enhance low water peak single mode fibers in full compliance with ITU-T-G.652.D (also available with G655 / G656 / G657 SM Fibre and OM1 / OM2 / OM3 & OM4 MM Fibre)
- Loose buffer tubes fully filled
- High tensile, galvanised, stranded steel wire used as integrated messenger wire
- UV Stabilized PE outer sheath, black

Technical Characteristics

FIBRE COUNT	DIAMETER (mm) Nominal	WEIGHT (Kg./Km) Nominal	TENSILE STRENGTH (N)		BENDING RADIUS (mm)		TEMPERATURE RANGE (IEC 60794-1-2-F1)	
			Installation	Operation	Installation	Operation	Installation	Operation
UPTO 12F	5.5 X 14.5	90	4500	2500	15D	20D	-10 ^o to +50 ^o C	-40 ^o to +70 ^o C
16/24F	6.0 X 15.0	90	4500	2500	15D	20D	-10 ^o to +50 ^o C	-40 ^o to +70 ^o C

Colour Coding - Fibre & Tube



* We provide Black ring mark over the fibre in case of more than 12 fibres

Special Features

- Central Loose tube construction
- Offers exceptional strength and corrosion resistance for aerial application
- Integrated High tensile messenger for superior strength and corrosion resistance.

Drum Length

2000/ 3000/ 4000 meters ± 5%

Mechanical Characteristics

Repeated Bending (IEC 60794-1-2-E6)	30 Cycle, 20 X D, 10 Kg Load, D = Cable Diameter
Torsion Resistance (IEC 60794-1-2-E7)	10 Cycle (± 180°) 5 Kg Weight, L= 2 Mtr
Crush Resistance (IEC 60794-1-2-E3)	1000 N (100 X 100mm) for 60 sec
Impact Resistance (IEC 60794-1-2-E4)	5 Kg, 3 Nos
Kink Resistance (IEC 60794-1-2-E10)	20 x D, D = Cable Diameter
Water Penetration (IEC 60794-1-2-F5)	1 Mtr Water Head, 3 Meter Cable Sample, 24 Hours

2F-288F MULTI-TUBE FIGURE-8 TYPE AERIAL OPTICAL FIBRE CABLE

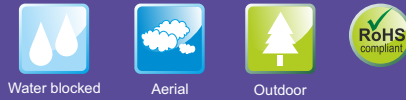

Applications

- Lashed aerial installation with rigorous load conditions, including heavy wind and ice
- Suitable for span length of 100 mtrs



Typical Cross section of 72 Fibre

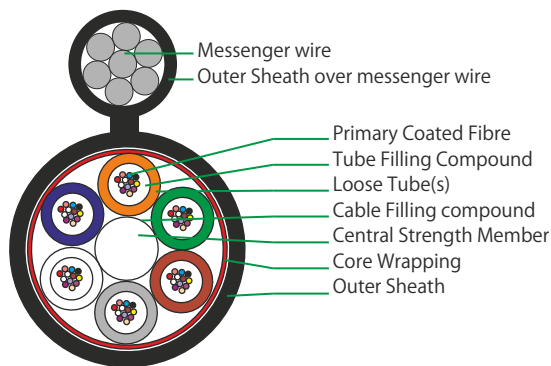

Cable Construction Details

- Upto 288 enhance low water peak single mode fibers in full compliance with ITU-T-G.652.D (also available with G655 / G656 / G657 SM Fibre and OM1 / OM2 / OM3 & OM4 MM Fibre)
- 2/4/6/8/12 fibre per tube combinations are available in 6/8/12 element construction
- Non-metallic anti-buckling FRP rod as Central Strength Member.
- Loose buffer tubes fully filled, S-Z Stranded
- Cable core fully filled (also available in dry core)
- S-Z core wrapped with polyester tape / water swelleble tape
- UV Stablized PE outer sheath, black
- High tensile, galvanised, stranded steel wire used as integrated messenger wire

Technical Characteristics

FIBRE COUNT	DIAMETER (mm) Nominal	WEIGHT (Kg./Km) Nominal	TENSILE STRENGTH (N)		BENDING RADIUS (mm)		TEMPERATURE RANGE (IEC 60794-1-2-F1)	
			Installation	Operation	Installation	Operation	Installation	Operation
UPTO 72F	10.5 X 19.5	155	8000	5000	10D	20D	-10° to +50° C	-40° to +70° C
96F	11.80 X 21.0	180	9600	6000	10D	20D	-10° to +50° C	-40° to +70° C
144F	14.5 X 23.5	230	10000	6500	10D	20D	-10° to +50° C	-40° to +70° C
192F-216F	15.0 X 24.0	230	8000	5000	10D	20D	-10° to +50° C	-40° to +70° C
288F	17.0 X 26.0	275	9500	6000	10D	20D	-10° to +50° C	-40° to +70° C

Color Coding - Fibre & Tube



Special Features

- Single layer S-Z stranded construction
- Offers exceptional strength and corrosion resistance for aerial application
- Integrated High tensile messenger for superior strength and corrosion resistance.
- Flexible buffer tubes provide easy fibre routing inside closure

Drum Length

2000/ 4000 meters ± 5%

Mechanical Characteristics

Repeated Bending (IEC 60794-1-2-E6)	30 Cycle, 20 X D, 5 Kg Load, D = Cable Diameter
Torsion Resistance (IEC 60794-1-2-E7)	10 Cycle (± 180°) 5 Kg Weight, L= 2 Mtr
Crush Resistance (IEC 60794-1-2-E3)	3000 N (100 X 100 mm) for 600 sec
Impact Resistance (IEC 60794-1-2-E4)	10 Nm, 3 Nos Height 500 mm, Weight =
Kink Resistance (IEC 60794-1-2-E10)	10 x D, D = Cable Diameter
Water Penetration (IEC 60794-1-2-F5)	1 Mtr Water Head, 3 Meter Cable Sample, 24 Hours

12F - 144F ALL DIELECTRIC FIG-8 AERIAL OPTICAL FIBRE CABLE

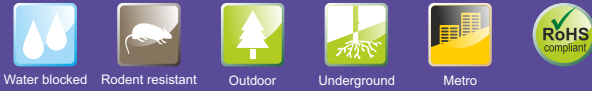

Applications

- Lashed aerial installation with rigorous load conditions.

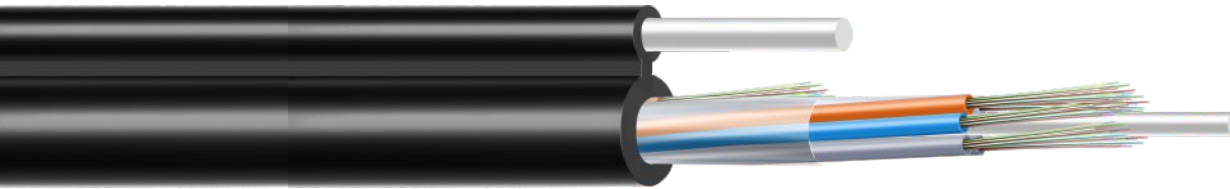

Typical Cross section of 144 Fibre

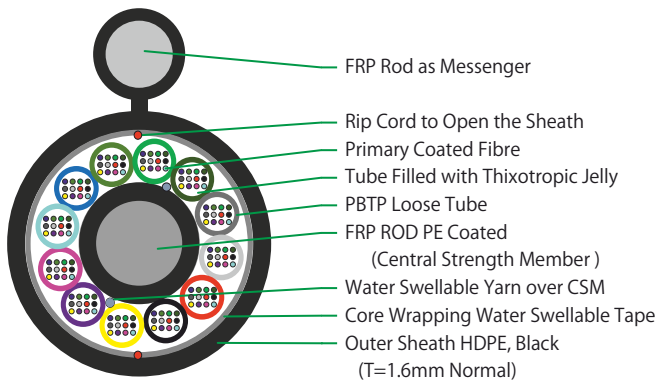

Cable Construction Details

- Up to 144 enhance low water peak single mode fibres in full compliance with ITU-T-G.652.D (also available with G655 / G656 / G657 SM Fibre and OM1 / OM2 / OM3 & OM4 MM Fibre).
- 6/8/12 fibre per tube combinations are available in 6/8/12 element construction
- Non metallic anti-buckling FRP rod as Central Strength Member.
- Loose buffer tubes fully filled with Thixotropic Jelly & Fibers.
- Loose buffer tubes S-Z Stranded (Water Swellable Yarn over CSM).
- Cable core is Dry & wrapped with water swellable tape.
- UV Stabilized PE outer sheath, Black (also available with HFFR / FRPVC).
- Non-metallic and anti-buckling element FRO rod used as Messenger.
- Rip cord to open the sheath

Technical Characteristics

FIBRE COUNT	DIAMETER (mm) Nominal	WEIGHT (Kg./Km) Nominal	TENSILE STRENGTH (N)		BENDING RADIUS (mm)		TEMPERATURE RANGE (IEC 60794-1-2-F1)	
			Installation	Operation	Installation	Operation	Installation	Operation
12	10.0 X 19.0	115	4000	2200	10D	20D	-10°C to +50°C	-40°C to +70°C
24	10.0 X 19.0	115	4000	2200	10D	20D	-10°C to +50°C	-40°C to +70°C
36	10.0 X 19.0	115	4000	2200	10D	20D	-10°C to +50°C	-40°C to +70°C
48	10.0 X 19.0	115	4000	2200	10D	20D	-10°C to +50°C	-40°C to +70°C
72	10.0 X 19.0	115	4000	2200	10D	20D	-10°C to +50°C	-40°C to +70°C
96	11.5 X 20.5	145	6000	3500	10D	20D	-10°C to +50°C	-40°C to +70°C
144	14.0 X 23.0	195	6500	3800	10D	20D	-10°C to +50°C	-40°C to +70°C

Fibre & Tube Colour Coding



For Fibre Count 12F We provide the above colour code

Special Features

- Single layer S-Z stranded construction
- Offers exceptional strength and corrosion resistance for aerial applicatioCable construction
- Flexible buffer tubes provide easy fibre routing inside closure

Drum Length

2000/ 4000 meters ± 5%

Mechanical Characteristics

Cable Bending Radius (mm) [IEC 60794-1-21-E11 A & B]	20 X D, D= Cable diameter
Impact Resistance (Nm) [IEC 60794-1-21-E4]	5 Nm, 3 Impacts
Crush Resistance (N) [IEC 60794-1-21-E3]	1000 N (100 X 100 mm)
Torsion Resistance [IEC 60794-1-21-E7]	10 Cycle (± 180°)
Water Penetration [IEC 60794-1-22-F5 B]	1 Meter Water Head, 3 Meters Cable Sample, 24 Hours

HYBRID (OPTICAL & COPPER)

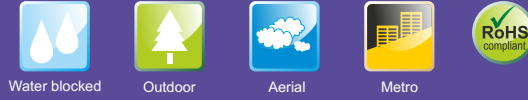

Applications

- Suitable for Under Ground Armoured Cable Upto 24F
- Axle Counting
- Signaling



Typical Cross section of Hybrid Cable

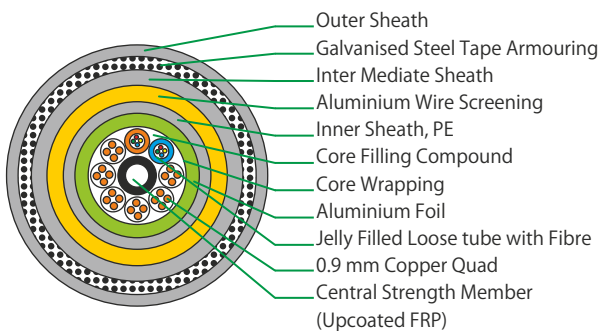

Cable Construction Details

Central Strength Member	Upcoated Fibre Reinforced Plastic-FRP (Non metallic)
Loose tube	2No. PBT Loose tube filled with Thixotropic Jelly
No. of Quads	6 Quads with Identification binders
Core wrapping	Polyester Tape applied helically
Moisture Barrier	Aluminium Foil
Inner Sheath	PE Inner Sheath
Screening	Aluminium wire screening
Tape	Barrium Chromate Tape
Intermediate Sheath	PE Intermediate Sheath
Armouring	Double Steel tape armouring
Outer Sheath	PE Outer Sheath

Color Coding - Fibre & Tube



Special Features

- Suitable for underground installation on pathways or roads
- Rodent & Termite proof.
- Robust under all conditions of operation, adjustment, replacement, storage and transport.
- Suitable for lightning prone areas.
- Better tensile strength.

Drum Length

1000 meters ± 5%

Mechanical Characteristics

Tensile strength	: 5000 N
Cable Bend Test	: 20D
Repeated Bending test	: 5 kg, 30 Cycles
Torsion Test	: 400 N
Crush Resistance	: 4000 N, 600 Sec
Impact Test	: 50 N, 10 Impact
Kink Test	: 20 D
Operating Temp.	: -20°C to +70°C
Water Penetration Test	: 3mtrs sample, 1mtr Height

Physical Characteristics

Cable Outer Diameter	: 30.0 + 4.0 mm
Nominal Cable Weight	: 1500 Kg/KM

Color Coding for Quad :

- No1 - White, Orange, Red , Green
- No2 - White, Blue, Red , Green
- No3 - White, Brown, Red , Green
- No4 - White, Green, Red , Green
- No5 - White, Yellow, Red , Green
- No6 - White, Black, Red , Green

**1F - 4F FRP FIG 8 EMBEDDED WITH MESSENGER WIRE
AERIAL DROP OPTICAL FIBRE CABLE**

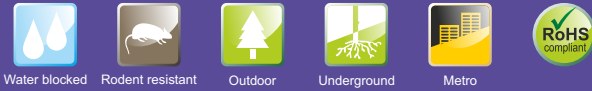

Application

Suitable for Aerial drop application



Typical Cross section

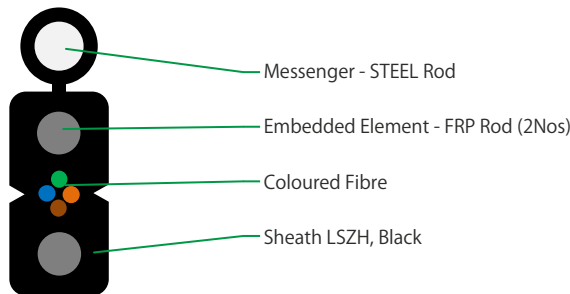

Cable Construction Details

- 1.Up to 4 enhance low water peak single mode fibres in full compliance with ITU-T-G.652D (also available with G.657A1 & G.657A2)
- Outer sheath LSZH, Black
- FRP Embedded in outer sheath as strength member.
- Steel wire as integrated messenger wire.

Technical Characteristics

FIBRE COUNT	DIAMENTION (mm) Nominal	WEIGHT (Kg./Km) Nominal	TENSILE STRENGTH (N)		BENDING RADIUS (mm)		TEMPERATURE RANGE (IEC 60794-1-2-F1)	
			Installation	Operation	Installation	Operation	Installation	Operation
1	2.0 X 5.0	20.0	850	450	10D	20D	-10°C to +50°C	-40°C to +70°C
2	2.0 X 5.0	20.0	850	450	10D	20D	-10°C to +50°C	-40°C to +70°C
4	2.0 X 5.0	20.0	850	450	10D	20D	-10°C to +50°C	-40°C to +70°C

Fibre colour coding

Without ring mark



Special Features

- Small size and Diamention for easy to strip.
- Easy access to the fibres.
- Quick cable entry & easy to peel.
- Low insertion and back reflection loss.
- Good durability.
- High temprature stability.
- Clean, gel free, Dry design

Mechanical Characteristics

Cable Bending Radius (mm) [IEC 60794-1-21-E11 A & B]	20 X D, D= Cable diameter
Impact Resistance (Nm) [IEC 60794-1-21-E4]	1 Nm, 1 Impacts
Crush Resistance (N) [IEC 60794-1-21-E3A]	500 N/ (100 X 100 mm)
Torsion Resistance [IEC 60794-1-21-E7]	5 Cycle (± 180°)

Drum Length

1000/ 2000 meters ± 5%

2F - 48F SINGLE SHEATH FLAT DROP WITH FRP EMBEDDED OPTICAL FIBRE CABLE

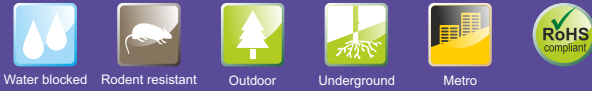

Applications

Suitable for duct installation

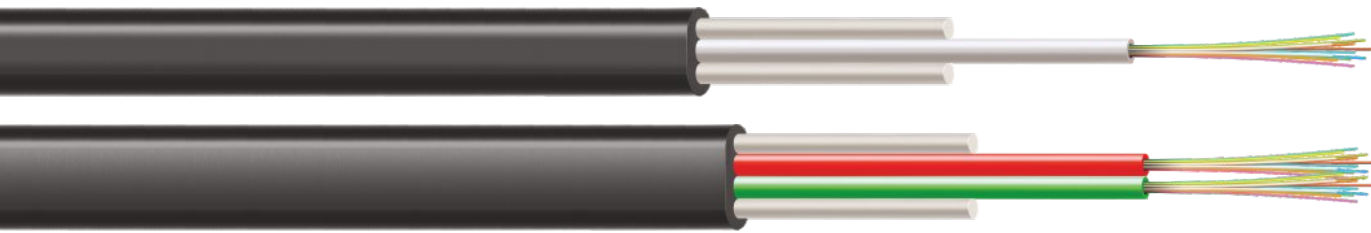

Typical Cross section

Cable Cross section of 48 Fibre

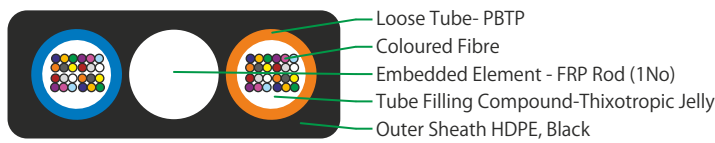

Cable Cross section of 24 Fibre

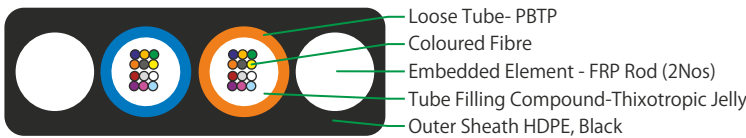

Cable Cross section of 12 Fibre

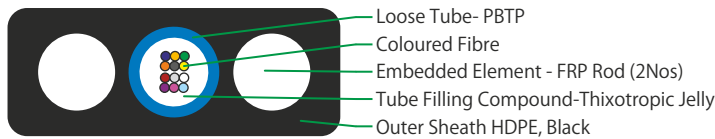

Cable Construction Details

- Up to 48 enhance low water peak single mode fibres in full compliance with ITU-T-G.652.D (also available with G.657A1 & G.657A2)
- Loose buffer tubes fully filled with Thixotropic Jelly & Fibres.
- UV Stabilized PE outer sheath, Black
- FRP Embedded in outer sheath.
- Rip cord to open the sheath

Technical Characteristics

FIBRE COUNT	DIMENSION (mm) Nominal	WEIGHT (Kg./Km) Nominal	TENSILE STRENGTH (N)		BENDING RADIUS (mm)		TEMPERATURE RANGE (IEC 60794-1-2-F1)	
			Installation	Operation	Installation	Operation	Installation	Operation
3.0 X 6.5	25	1300	650	10D	20D	-10°C to +50°C	-40°C to +70°C	
12	3.7 X 7.7	35	2000	1000	10D	20D	-10°C to +50°C	-40°C to +70°C
4.3 X 7.8	40	2000	1000	10D	20D	-10°C to +50°C	-40°C to +70°C	
24	3.6 X 8.6	40	1300	650	10D	20D	-10°C to +50°C	-40°C to +70°C
48	4.5 x 9.6	50	1500	750	10D	20D	-10°C to +50°C	-40°C to +70°C

Fibre & Tube colour coding

Without ring mark



With ring mark



- More than 12 fibre we provide Ring mark above the coloured fibre.

Special Features

- Completely dielectric cable/ non metallic cable immune to electromagnetic interferences.
- The cable is usually used in rural areas as self-supporting drop cable, enable subscribers access to the distribution network.
- Small size and Dimension for easy to strip.
- Excellent crush resistance because of the flat shape jacket.
- Good mechanical and temperature performance.

Drum Length

2000/ 4000 meters ± 5%

12F - 576F SINGLE JACKET MULTI TUBE MICRO DUCT (200 MICRON) FIBRE OPTIC CABLE



Applications

- Suitable for Duct Installation, pulled & blown

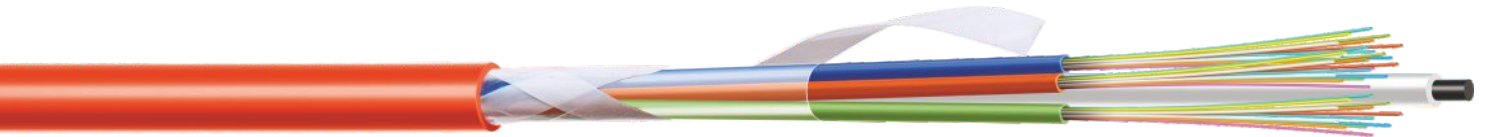

Typical Cross section of 96F

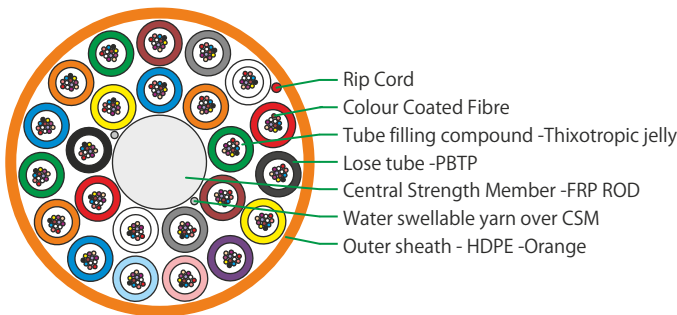

Cable Construction Details

- Up to 576 enhance low water peak single mode fibres in full compliance with ITU-T-G.657A1 (Also available with G.657A2).
- 6/8/12/24 fibre per tube combinations are available in 6/8/12/18/24 element constructions.
- Non metallic anti-buckling FRP rod as Central Strength Member.
- Loose buffer tubes fully filled with Thixotropic Jelly & Fibers.
- Loose buffer tubes S-Z Stranded (Water Swellable Yarn over CSM).
- UV Stabilized PE outer sheath, Black.
- Rip cord to open the sheath.

Technical Characteristics

FIBRE COUNT	DIAMETER (mm) Nominal	WEIGHT (Kg./Km) Nominal	TENSILE STRENGTH (N)		BENDING RADIUS (mm)		TEMPERATURE RANGE (IEC 60794-1-2-F1)	
			Installation	Operation	Installation	Operation	Installation	Operation
12-72	4.7	20	500	300	10D	20D	-10°C to +50°C	-40°C to +70°C
96	5.4	28	1000	750	10D	20D	-10°C to +50°C	-40°C to +70°C
144	7.0	45	1800	1200	10D	20D	-10°C to +50°C	-40°C to +70°C
192	7.1	43	1200	600	10D	20D	-10°C to +50°C	-40°C to +70°C
216	7.1	43	1200	600	10D	20D	-10°C to +50°C	-40°C to +70°C
288	8.1	62	1500	1000	10D	20D	-10°C to +50°C	-40°C to +70°C
144(24F/Tube)	5.7	30	1000	500	10D	20D	-10°C to +50°C	-40°C to +70°C
192(24F/Tube)	6.6	43	1500	1000	10D	20D	-10°C to +50°C	-40°C to +70°C
216(24F/Tube)	7.2	50	1500	1000	10D	20D	-10°C to +50°C	-40°C to +70°C
288(24F/tube)	8.8	70	1500	1000	10D	20D	-10°C to +50°C	-40°C to +70°C
432(24F/Tube)	9.0	70	1200	800	10D	20D	-10°C to +50°C	-40°C to +70°C
576(24F/Tube)	10.4	100	1500	1000	10D	20D	-10°C to +50°C	-40°C to +70°C

Fibre & Tube colour coding

Without ring mark



With ring mark



- More than 12 fibre we provide Black ring mark above the colored fibre.
- More than 12 Tube we provide Stripe above the colored tube.

Special Features

- Single layer and Multi-layer stranded construction.
- Low friction coefficient sheath design and materials assures long air blowing distance.
- Easy to bend, laying and operate with small diameter, light weight.
- Flexible buffer tubes provide easy fibre routing inside closure.
- All nonmetallic structure, so there is no requirements for grounding.
- This cable is suitable for construction in crowded metropolitan area network pipelines and avoiding destructive excavation in the past.

Mechanical Characteristics

Cable Bending Radius (mm) [IEC 60794-1-21-E11 A & B]	20 X D, D= Cable diameter
Impact Resistance (Nm) [IEC 60794-1-21-E4]	3 Nm, 1 Impacts
Crush Resistance (N) [IEC 60794-1-21-E3]	1000 N (100 X 100 mm)
Torsion Resistance [IEC 60794-1-21-E7]	10 Cycle (± 180°)
Water Penetration [IEC 60794-1-22-F5 B]	1 Meter Water Head, 3 Meters Cable Sample, 24 Hours

Drum Length

2000/ 4000 meters ± 5%

12F- 576F SINGLE SHEATH MULTI TUBE MICRO DUCT (250 MICRON) FIBRE OPTIC CABLE



Applications

- Suitable for Duct Installation, pulled & blown.

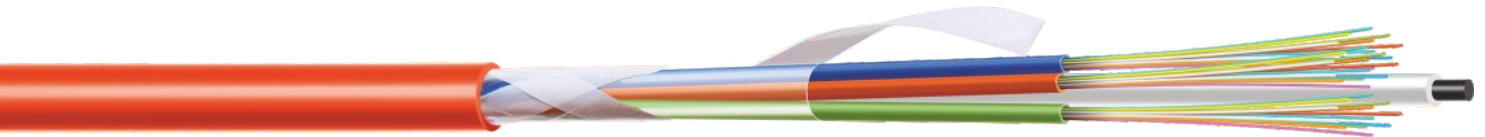

Typical Cross section of 96F

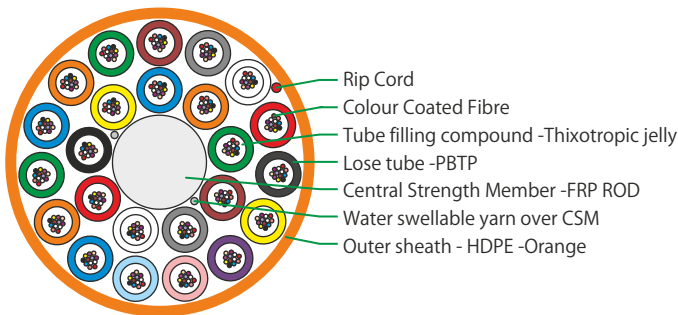

Cable Construction Details

- Up to 576 enhance low water peak single mode fibres in full compliance with ITU-T-G.652.D (also available with G.657A1 & G.657A2)
- 6/8/12/24 fibre per tube combinations are available in 6/8/12/18/24 element constructions.
- Nonmetallic anti-buckling FRP rod as Central Strength Member.
- Loose buffer tubes fully filled with Thixotropic Jelly & Fibers.
- Loose buffer tubes S-Z Stranded (Water Swellable Yarn over CSM)UV Stabilized PE outer sheath, Black.
- Rip cord to open the sheath.

Technical Characteristics

FIBRE COUNT	DIAMETER (mm) Nominal	WEIGHT (Kg./Km) Nominal	TENSILE STRENGTH (N)		BENDING RADIUS (mm)		TEMPERATURE RANGE (IEC 60794-1-2-F1)	
			Installation	Operation	Installation	Operation	Installation	Operation
12-72(12F/Tube)	5.4	24	600	350	10D	20D	-10°C to +50°C	-40°C to +70°C
96(12F/Tube)	6.2	35	1000	750	10D	20D	-10°C to +50°C	-40°C to +70°C
144(12F/Tube)	8.0	55	1500	1000	10D	20D	-10°C to +50°C	-40°C to +70°C
192(12F/Tube)	8.2	55	1200	750	10D	20D	-10°C to +50°C	-40°C to +70°C
216(12F/Tube)	8.2	55	1200	750	10D	20D	-10°C to +50°C	-40°C to +70°C
288(12F/Tube)	9.4	75	1500	1000	10D	20D	-10°C to +50°C	-40°C to +70°C
144(24F/Tube)	6.8	40	1000	500	10D	20D	-10°C to +50°C	-40°C to +70°C
192(24F/Tube)	8.0	58	2000	1200	10D	20D	-10°C to +50°C	-40°C to +70°C
216(24F/Tube)	8.8	65	1500	800	10D	20D	-10°C to +50°C	-40°C to +70°C
288(24F/Tube)	10.6	100	3000	1500	10D	20D	-10°C to +50°C	-40°C to +70°C
432(12F/Tube)	10.8	95	1500	800	10D	20D	-10°C to +50°C	-40°C to +70°C
576(12F/Tube)	12.6	130	3000	1500	10D	20D	-10°C to +50°C	-40°C to +70°C

Fibre & Tube colour coding

Without ring mark



With ring mark



- More than 12 fibre we provide Black ring mark above the colored fibre.
- More than 12 Tube we provide Stripe above the colored tube.

Special Features

- Single layer and Multi-layer stranded construction.
- Low friction coefficient sheath design and materials assures long air blowing distance.
- Easy to bend, laying and operate with small diameter, light weight.
- Flexible buffer tubes provide easy fibre routing inside closure.
- All nonmetallic structure, so there is no requirements for grounding.
- This cable is suitable for construction in crowded metropolitan area network pipelines and avoiding destructive excavation in the past.

Mechanical Characteristics

Cable Bending Radius (mm) [IEC 60794-1-21-E11 A & B]	20 X D, D= Cable diameter
Impact Resistance (Nm) [IEC 60794-1-21-E4]	3 Nm, 1 Impacts
Crush Resistance (N) [IEC 60794-1-21-E3]	1000 N (100 X 100 mm)
Torsion Resistance [IEC 60794-1-21-E7]	10 Cycle (± 180°)
Water Penetration [IEC 60794-1-22-F5 B]	1 Meter Water Head, 3 Meters Cable Sample, 24 Hours

Drum Length

2000/ 4000 meters ± 5%

12F-96 SINGLE SHEATH FIBRE SUPER LEAN, MICRO OPTICAL FIBER CABLE

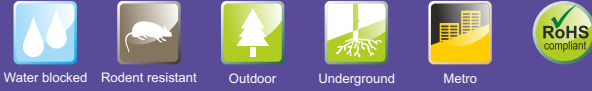

Application

- Suitable for Installation in Micro Duct.

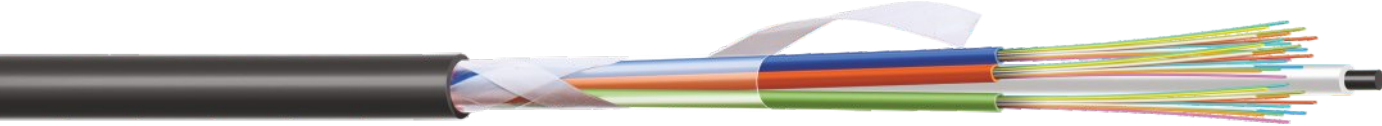

Typical Cross section of 48 Fibre

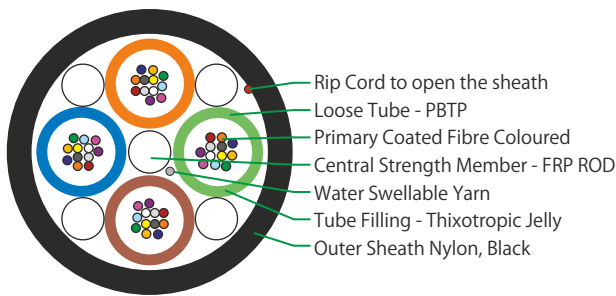

Cable Construction Details

- Up to 96 enhance low water peak single mode fibres in full compliance with ITU-T-G.652.D (also available G.657A1 & G657A2).
- Non metallic anti-buckling FRP rod as Central Strength Member.
- Loose buffer tubes fully filled with Thixotropic Jelly & Fibres.
- Loose buffer tubes S-Z Stranded along with FRP to provide a circular shaped cable.
- Cable core is Dry (Water Swellable Yarn over CSM).
- Cable core is wrapped with water swellable tape.
- Outer sheath NYLON, Black.
- Rip cord to open the sheath.

Technical Characteristics

FIBRE COUNT	DIAMETER (mm) Nominal	WEIGHT (Kg./Km) Nominal	TENSILE STRENGTH (N)		BENDING RADIUS (mm)		TEMPERATURE RANGE (IEC 60794-1-2-F1)	
			Installation	Operation	Installation	Operation	Installation	Operation
200um fibre G.657A1 & G.657A2 With 24F/tube design								
24F – 48F	4.0	15	300 N	150 N	30D	40D	-10°C to +50°C	-30°C to +70°C
96F	4.8	20	300 N	150 N	30D	40D	-10°C to +50°C	-30°C to +70°C
250um fibre G.652D, G.657A1 & G.657A2 With 12F/tube design								
12F – 48F	4.3	16	250 N	120 N	30D	40D	-10°C to +50°C	-30°C to +70°C

Fibre & Tube colour coding

Without ring mark

Blue	Orange	Green	Brown	Grey	White	Red	Black	Yellow	Voilet	Pink	Aqua
------	--------	-------	-------	------	-------	-----	-------	--------	--------	------	------

With ring mark

Blue	Orange	Green	Brown	Grey	White	Red	Natural	Yellow	Voilet	Pink	Aqua
------	--------	-------	-------	------	-------	-----	---------	--------	--------	------	------

More than 12 fibre we provide Black ring mark above the colored fibre.

Special Features

- Single layer S-Z stranded construction.
- Flexible buffer tubes provide easy fibre routing inside closure.
- Completely dielectric cable immune to electromagnetic interferences.
- Offers strength and corrosion resistance for aerial application also.

Mechanical Characteristics

Cable Bending Radius (mm) [IEC 60794-1-21-E11 A & B]	40 X D, D= Cable diameter
Impact Resistance (Nm) [IEC 60794-1-21-E4]	1 Nm, 1 Impacts
Crush Resistance (N) [IEC 60794-1-21-E3 A]	300 N / (100 X 100 mm)1
Torsion Resistance [IEC 60794-1-21-E7]	5 Cycle (± 180°)
Water Penetration [IEC 60794-1-22-F5 B]	1Meter Water Head, 3 Meters Cable Sample, 24 Hours

Drum Length

2000/ 4000 meters ± 5%

1F - 24F SINGLE SHEATH MICRO MODULE OPTICAL FIBRE CABLE

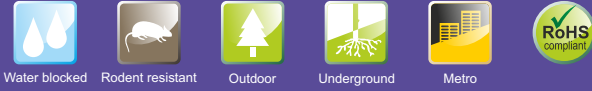

Applications

- The universal design is suited for use in most network arenas, including backbone, access and distribution.
- Quick fibre preparation ready for installation
- Installation Outdoor to Indoor

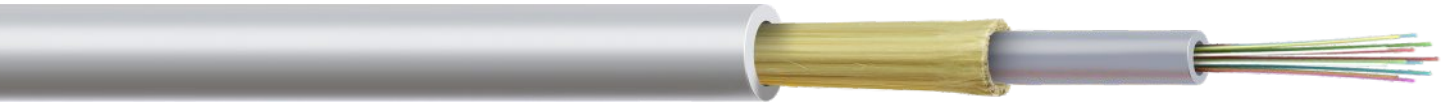

Typical Cross section of 12 Fibre

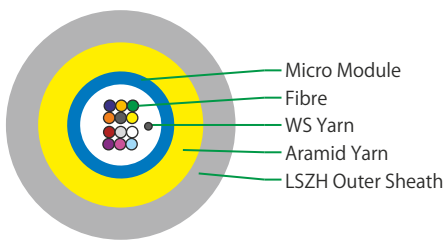

Cable Construction Details

- The micro-module unit consist of up-to 24fibres, an easily strippable and flexible.
- High Modulus, Aramid yarn as peripheral strength member
- LSZH Outer sheath

Technical Characteristics

FIBRE COUNT	DIAMETER (mm) Nominal	WEIGHT (Kg./Km) Nominal	TENSILE STRENGTH (N)		BENDING RADIUS (mm)		TEMPERATURE RANGE (IEC 60794-1-2-F1)	
			Installation	Operation	Installation	Operation	Installation	Operation
1F	4.0	15	300	150	10D	20D	-5°C to +50°C	-10°C to +60°C
2F	4.0	15	300	150	10D	20D	-5°C to +50°C	-10°C to +60°C
4F	4.0	15	300	150	10D	20D	-5°C to +50°C	-10°C to +60°C
6F	4.5	18	300	150	10D	20D	-5°C to +50°C	-10°C to +60°C
8F	4.5	18	300	150	10D	20D	-5°C to +50°C	-10°C to +60°C
12F	4.8	22	300	150	10D	20D	-5°C to +50°C	-10°C to +60°C
24F	5.5	26	300	150	10D	20D	-5°C to +50°C	-10°C to +60°C

Fiber Colour Coding



Micro Module Colour Coding

Blue For Fibre Count 12F We provide the above colour code

Special Features

- Reduced diameter micro modules
- Flexible Micro modules are easily removed without the need for tools
- Reduce installation time and costs
- Small cable diameter & light weight
- Requires no grounding or bonding due to all-dielectric construction
- All dielectric construction.

Mechanical Characteristics

Impact Resistance [IEC 60794-1-2-E4]	Height 0.3 meters, Weight = 0.1 Kg, 1 Nos
Crush Resistance [IEC 60794-1-2-E3]	500 N [100 X 100 mm] for 10 minutes, 3 times 500 mm apart
Torsion Resistance [IEC 60794-1-2-E7]	10 Cycle [± 180°] 20 N Weight, Length under Test-1 meters
Water Penetration [IEC 60794-1-22-F5 B/C]	1 Meter Water Head, 3 Meters Cable Sample, 24 Hours

Drum Length

2000/ 4000 meters ± 5%

**6F - 144F SINGLE SHEATH MULTI TUBE MICRO MODULE
4FRP DESIGN DUCT / ADSS OPTICAL FIBRE CABLE**

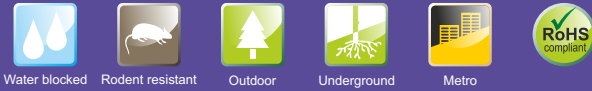

Applications

- The universal design is suited for use in most network arenas, including backbone, access and distribution.
- Quick fibre preparation ready for installation.
- Installation within ducts/overhead using blown on pulling techniques.

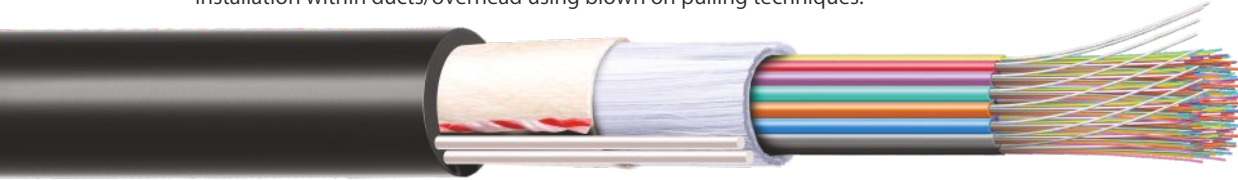

Typical Cross section of 36 Fibres

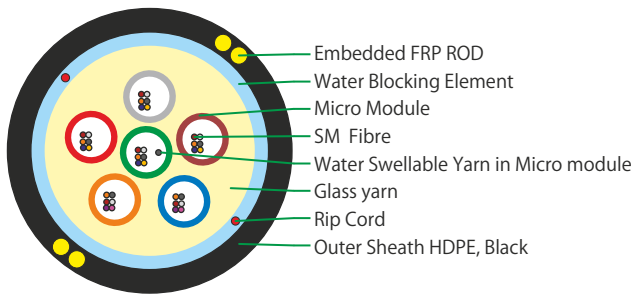

Cable Construction Details

- The micro-module unit consist of 6 fibres along with WS Yarn an easily strippable and flexible.
- Glass yarn as peripheral strength member.
- Non-metallic and anti-buckling element FRP rod (4 nos) used as Embedded Strength Member.
- Water Blocking Element wrapped over Aramid Yarn.
- HDPE Outer sheath, Black Colour, UV Stabilized.

Technical Characteristics

FIBRE COUNT	DIAMETER (mm) Nominal	WEIGHT (Kg./Km) Nominal	TENSILE STRENGTH (N)		BENDING RADIUS (mm)		TEMPERATURE RANGE (IEC 60794-1-2-F1)	
			Installation	Operation	Installation	Operation	Installation	Operation
6F	6.0	32	1800	800	15D	20D	-5°C to +40°C	-30°C to +60°C
12F	7.5	45	2400	1000	15D	20D	-5°C to +40°C	-30°C to +60°C
24F	7.5	45	2400	1000	15D	20D	-5°C to +40°C	-30°C to +60°C
36F	8.5	60	2400	1000	15D	20D	-5°C to +40°C	-30°C to +60°C
48F	8.5	60	2800	1200	15D	20D	-5°C to +40°C	-30°C to +60°C
72F	10.5	90	4000	1800	15D	20D	-5°C to +40°C	-30°C to +60°C
96F	11.5	105	4500	2100	15D	20D	-5°C to +40°C	-30°C to +60°C
144F	13.0	130	5400	2500	15D	20D	-5°C to +40°C	-30°C to +60°C

Fiber & Micro Module Colour Coding

Fiber Colour Coding



Micro Module Colour Coding



- For Fibre Count 12F We provide the above colour code
- For Higher Fibre count we provide contrast dot marking of above colour code

Special Features

- Reduced diameter micro modules.
- Flexible Micro modules are easily removed without the need for tools.
- Reduce installation time and costs.
- Small cable diameter & lightweight.
- Requires no grounding or bonding due to all-dielectric construction.

Drum Length

2000/ 4000 meters ± 5%

Mechanical Characteristics

Kink Resistance (mm) [IEC 60794-1-2-E10]	15 x D, D = Cable Diameter
Impact Resistance (Nm) [IEC 60794-1-2-E4]	5 Nm, 3 Nos at 500mm apart
Crush Resistance (N) [IEC 60794-1-2-E3]	2000 N [100 X 100 mm] for 60 sec
Torsion Resistance [IEC 60794-1-2-E7]	5 Cycle [± 180°] 40 N Weight, Length under Test-2 meters
Repeated Bending [IEC 60794-1-2-E6]	30 Cycle, r = 20 X D, 5 Kg Load, D = Cable Diameter
Water Penetration [IEC 60794-1-22-F5 B/C]	1 Meter Water Head, 3 Meters Cable Sample, 24 Hours
Micro Module Strip-ability	Micro Module Easy Strippable, 1 meter in 1 minutes

12F - 288F SINGLE SHEATH MULTI TUBE MICRO MODULE
4FRP DESIGN DUCT / ADSS OPTICAL FIBRE CABLE

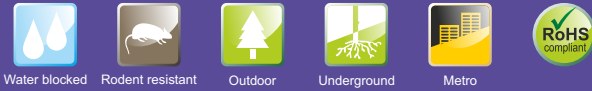

Applications

- The universal design is suited for use in most network arenas, including backbone, access and distribution.
- Quick fibre preparation ready for installation.
- Installation within ducts using blown on pulling techniques.

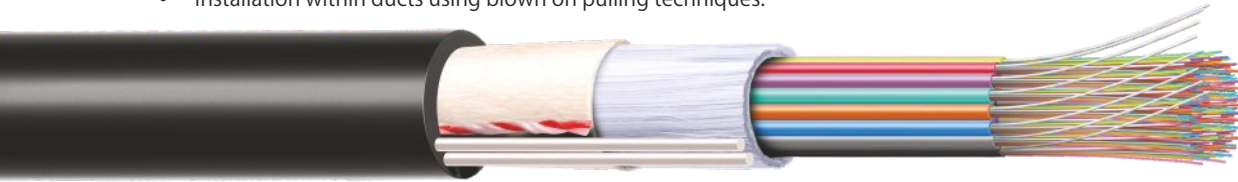

Typical Cross section of 144 Fibres

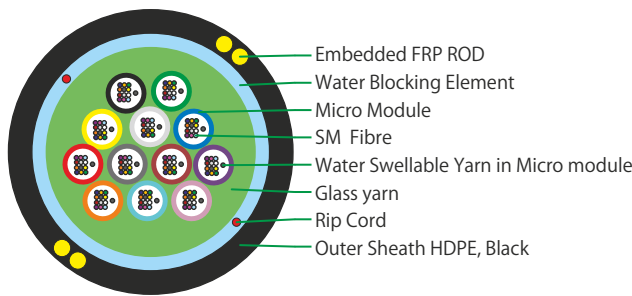

Cable Construction Details

- The micro-module unit consist of 12 fibres along with WS Yarn an easily strippable and flexible.
- Glass yarn as peripheral strength member.
- Non-metallic and anti-buckling element FRP rod (4 nos) used as Embedded Strength Member.
- Water Blocking Element wrapped over Aramid Yarn.
- HDPE Outer sheath, Black Colour, UV Stabilized.

Technical Characteristics

FIBRE COUNT	DIAMETER (mm) Nominal	WEIGHT (Kg./Km) Nominal	TENSILE STRENGTH (N)		BENDING RADIUS (mm)		TEMPERATURE RANGE (IEC 60794-1-2-F1)	
			Installation	Operation	Installation	Operation	Installation	Operation
12F	6.0	32	1500	700	15D	20D	-5°C to +45°C	-30°C to +60°C
24F	7.5	40	2000	900	15D	20D	-5°C to +45°C	-30°C to +60°C
36F	7.5	40	2000	900	15D	20D	-5°C to +45°C	-30°C to +60°C
48F	8.5	50	2800	1200	15D	20D	-5°C to +45°C	-30°C to +60°C
72F	10.5	80	3800	1600	15D	20D	-5°C to +45°C	-30°C to +60°C
96F	11.2	100	4500	2000	15D	20D	-5°C to +45°C	-30°C to +60°C
144F	12.3	110	5000	2300	15D	20D	-5°C to +45°C	-30°C to +60°C
288F	15.0	160	5000	2300	15D	20D	-5°C to +45°C	-30°C to +60°C

Fibre & Micro Module Colour Coding



- For Fiber Count 12F We provide the above colour code
- For Higher Fiber count we provide contrast dot marking of above colour code

Special Features

- Reduced diameter micro modules.
- Flexible Micro modules are easily removed without the need for tools.
- Reduce installation time and costs.
- Small cable diameter & lightweight.
- Requires no grounding or bonding due to all-dielectric construction.

Drum Length

2000/ 4000 meters ± 5%

Mechanical Characteristics

Kink Resistance (mm) [IEC 60794-1-2-E10]	15 x D, D = Cable Diameter
Impact Resistance (Nm) [IEC 60794-1-2-E4]	5 Nm, 3 Nos at 500mm apart
Crush Resistance (N) [IEC 60794-1-2-E3]	2000 N [100 X 100 mm] for 60 sec
Torsion Resistance [IEC 60794-1-2-E7]	5 Cycle [± 180°] 40 N Weight, Length under Test-2 meters
Repeated Bending [IEC 60794-1-2-E6]	30 Cycle, r = 20 X D, 5 Kg Load, D = Cable Diameter
Water Penetration [IEC 60794-1-22-F5 B/C]	1 Meter Water Head, 3 Meters Cable Sample, 24 Hours
Micro Module Strip-ability	Micro Module Easy Strippable, 1 meter in 1 minutes

12F-1152F SINGLE SHEATH MULTI TUBE MICRO MODULE WITH 2FRP & GLASS YARN DUCT FIBRE OPTIC CABLE

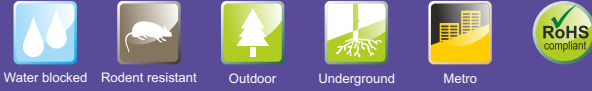

Applications

- The universal design is suited for use in most network arenas, including backbone, access and distribution.
- Quick fibre preparation ready for installation.
- Installation within ducts using blown on pulling techniques.



Typical Cross section of 144 Fibre

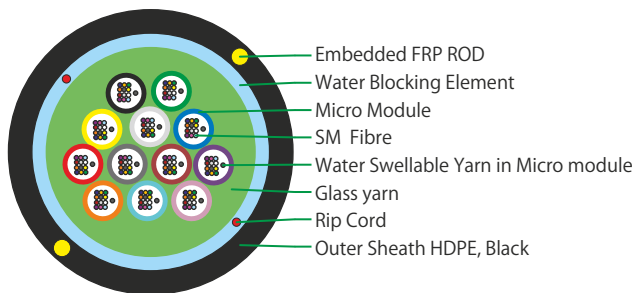

Cable Construction Details

- The micro-module unit consist of 12 fibres along with WS Yarn an easily strippable and flexible.
- Water Blocking Glass yarn as peripheral strength member.
- Non-metallic and anti-buckling element FRP rod (2 nos) used as Embedded Strength Member.
- Water Blocking Element wrapped over Aramid Yarn.
- HDPE Outer sheath, Black Colour, UV Stabilized.

Technical Characteristics

FIBRE COUNT	DIAMETER (mm) Nominal	WEIGHT (Kg./Km) Nominal	TENSILE STRENGTH (N)		BENDING RADIUS (mm)		TEMPERATURE RANGE (IEC 60794-1-2-F1)	
			Installation	Operation	Installation	Operation	Installation	Operation
12F	5.7	28	800	350	10D	20D	-5°C to +45°C	-30°C to +60°C
24F	7.0	35	800	350	10D	20D	-5°C to +45°C	-30°C to +60°C
36F	7.4	38	800	350	10D	20D	-5°C to +45°C	-30°C to +60°C
48F	7.8	45	1300	500	10D	20D	-5°C to +45°C	-30°C to +60°C
72F	8.4	52	1300	500	10D	20D	-5°C to +45°C	-30°C to +60°C
96F	9.4	65	1800	600	10D	20D	-5°C to +45°C	-30°C to +60°C
144F	10.4	78	1800	600	10D	20D	-5°C to +45°C	-30°C to +60°C
288F	12.4	112	2200	800	10D	20D	-5°C to +45°C	-30°C to +60°C
432F	15.5	170	3000	1200	10D	20D	-5°C to +45°C	-30°C to +60°C
576F	17.2	202	3000	1200	10D	20D	-5°C to +45°C	-30°C to +60°C
720F	18.5	228	3000	1200	10D	20D	-5°C to +45°C	-30°C to +60°C
864F	19.5	254	3000	1200	10D	20D	-5°C to +45°C	-30°C to +60°C
1152F	22.0	305	3000	1200	10D	20D	-5°C to +45°C	-30°C to +60°C

Fiber & Micro Module Colour Coding



For Fiber Count 12F We provide the above colour code
 For Higher Fiber count we provide contrast dot marking of above colour code

Special Features

- Reduced diameter micro modules.
- Flexible Micro modules are easily removed without the need for tools.
- Reduce installation time and costs.
- Small cable diameter & lightweight.
- Requires no grounding or bonding due to all-dielectric construction.

Drum Length

2000/ 4000 meters ± 5%

Mechanical Characteristics

Kink Resistance (mm) [IEC 60794-1-2-E10]	10 x D, D = Cable Diameter
Impact Resistance (Nm) [IEC 60794-1-2-E4]	5 Nm, 3 Nos at 500mm apart
Crush Resistance (N) [IEC 60794-1-2-E3]	2000 N [100 X 100 mm] for 60 sec
Torsion Resistance [IEC 60794-1-2-E7]	5 Cycle [± 180°] 40 N Weight, Length under Test-1 meters
Repeated Bending [IEC 60794-1-2-E6]	30 Cycle, r = 20 X D, 5 Kg Load, D = Cable Diameter
Water Penetration [IEC 60794-1-22-F5 B/C]	1 Meter Water Head, 3 Meters Cable Sample, 24 Hours

2F-96F SINGLE SHEATH ULTRA LIGHT WEIGHT MICRO MODULE OPTICAL FIBRE CABLE



Applications

- This Cable is suitable for FTTH Roll out and a range of light weight drop type design / construction cables for installation in the Fibre Network in Overhead and Underground environments.
- This cable meets the breaking load requirement less than 2000 N in the interests of safety for overhead applications. It benefits from unique safety features of predictable breaking load which is essential in the event of vehicle strike, to protect equipment and minimize the risk of loss of tangible assets that could potentially harm personnel, property or equipment and will be a fully safe aerial installation solution. Span length of 68 meters maximum.

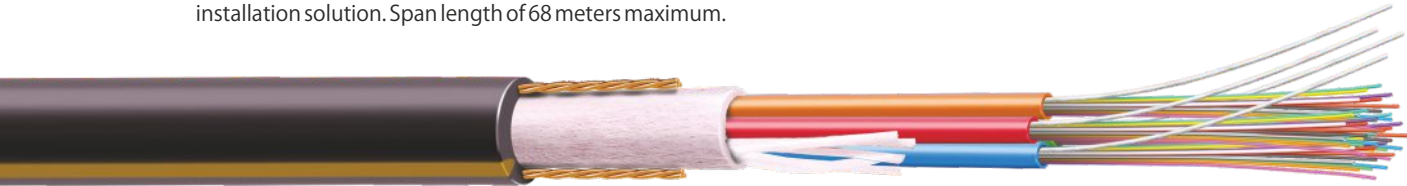

Typical Cross section of 48 Fibres

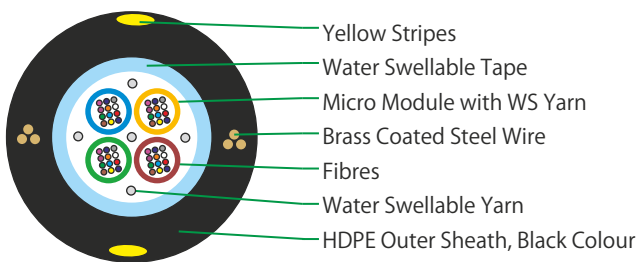

Cable Construction Details

- The Dry Micro Module consist of 12 fibres an easily strippable and flexible. WS Yarn along with Fibres.
- Dry type core filled with Water Swellable Material.
- Fillers/Dummy for maintaining circularity of cable core.
- Cable Core Wrapped with WS Tape.
- Brass Coated Steel Wire as Embedded strength members protect from against buckling.
- Outer Sheath of HDPE, UV Stabilized, Black Colour.

Technical Characteristics

FIBRE COUNT	DIAMETER (mm) Nominal	WEIGHT (Kg./Km) Nominal	TENSILE STRENGTH (N)		BENDING RADIUS (mm)		TEMPERATURE RANGE (IEC 60794-1-2-F1)	
			Installation	Operation	Installation	Operation	Installation	Operation
2F	7.0	36	950	500	10D	20D	-10°C to +60°C	-30°C to +85°C
4F	7.0	36	950	500	10D	20D	-10°C to +60°C	-30°C to +85°C
6F	7.0	36	950	500	10D	20D	-10°C to +60°C	-30°C to +85°C
8F	7.0	36	950	500	10D	20D	-10°C to +60°C	-30°C to +85°C
12F	7.0	36	950	500	10D	20D	-10°C to +60°C	-30°C to +85°C
24F	7.0	36	950	500	10D	20D	-10°C to +60°C	-30°C to +85°C
48F	7.0	36	950	500	10D	20D	-10°C to +60°C	-30°C to +85°C
72F	7.0	36	500	950	10D	20D	-10°C to +60°C	-30°C to +85°C
96F	7.0	36	500	950	10D	20D	-10°C to +60°C	-30°C to +85°C

Fibre & Micro Module Colour Coding



For Fibre Count 12F We provide the above colour code
For Higher Fibre count we provide contrast dot marking of above colour code

Special Features

- Reduced diameter Micro Module manufactured from soft and flexible elastomeric material.
- Micro Module are kink resistant and easily removed without the need for tools.
- Diametrically opposite embedded strength members provide excellent crush protection and Tensile performance.
- Ultra-compactness, easier storage and faster installation.

Mechanical Characteristics

Kink Resistance (mm) [IEC 60794-1-2-E10]	10 x D, D = Cable Diameter
Impact Resistance (Nm) [IEC 60794-1-2-E4]	Height 0.5 meters, Weight =1 Kg, 3 Nos
Crush Resistance (N) [IEC 60794-1-2-E3]	2000 N [100 X 100 mm] for 60 sec
Torsion Resistance [IEC 60794-1-2-E7]	10 Cycle [± 180°] 1 Kg Weight, Length under Test-2 meters
Repeated Bending [IEC 60794-1-2-E6]	30 Cycle, r = 20 X D, 1 Kg Load, D = Cable Diameter
Water Penetration [IEC 60794-1-22-F5 B/C]	1 Meter Water Head, 3 Meters Cable Sample, 24 Hours

Drum Length

2000/ 4000meters ± 5%

1F TO 6F DOUBLE SHEATH FTA (FIBRE TO ANTENNA) OPTICAL FIBRE CABLE



Applications

- To provide high-speed, low-latency and reliable connectivity between the cellular base stations and the remote radio heads (RRHs) or antennas.
- Wireless telecommunications networks.



Typical Cross section

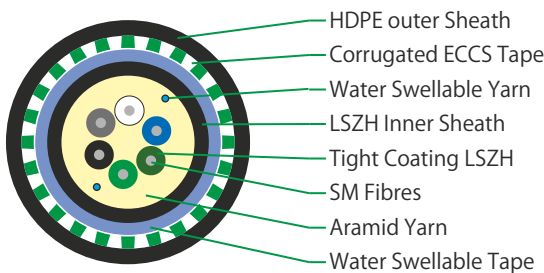

Cable Construction Details

- Tight Coating [Tight Buffer].
- Peripheral Strength member.
- Inner Sheath LSZH.
- Wrapping Tape.
- Corrugated ECCS tape.
- HDPE Outer sheath.

Technical Characteristics

FIBRE COUNT	TIGHT BUFFER DIAMETER (µm)Nominal	DIAMETER (mm) Nominal	WEIGHT (Kg./Km) Nominal	TENSILE STRENGTH (N)		BENDING RADIUS (mm)		TEMPERATURE RANGE (IEC 60794-1-2-F1)	
				Installation	Operation	Installation	Operation	Installation	Operation
2	900	8.0	60	500	300	10D	20D	-20°C to +70°C	-20°C to +70°C
4	900	8.2	62	500	300	10D	20D	-20°C to +70°C	-20°C to +70°C
6	900	9.5	82	500	300	10D	20D	-20°C to +70°C	-20°C to +70°C

Fiber Color Coding

Fnatural or as per Customer Require EIA 359-A, IEC Publication 304(4) TIA 598D, IEC TR 63194 Latest Issue

Tight Buffer Color Coding



Special Features

- Enhanced Data Rates.
- Lower Latency.
- Increased Capacity.
- Longer Distance Reach.
- Mechanical Protection.
- Rodent Resistant.

Mechanical Characteristics

Impact Resistance (Nm) [IEC 60794-1-2-E4]	1 J, 3 Impacts
Crush Resistance (N) [IEC 60794-1-2-E3]	1500 N [100 X 100 mm] for 5 minutes, 3 times at 150 mm apart
Torsion Resistance [IEC 60794-1-2-E7]	10 Cycle [± 180°] 1 Kg Weight, Length under Test-2 meters
Repeated Bending [IEC 60794-1-2-E6]	30 Cycle, r = 20 X D, 1 Kg Load, D = Cable Diameter

Drum Length

2000/ 4000meters ± 5%

1F - 6F DOUBLE SHEATH SPIRAL ARMoured WITH WIRE BRAIDING OPTICAL FIBRE CABLE



Applications

- To provide high-speed, low-latency and reliable connectivity between the cellular base stations and the remote radio heads (RRHs) or antennas.
- Wireless telecommunications networks.



Typical Cross section of 24 Fibre

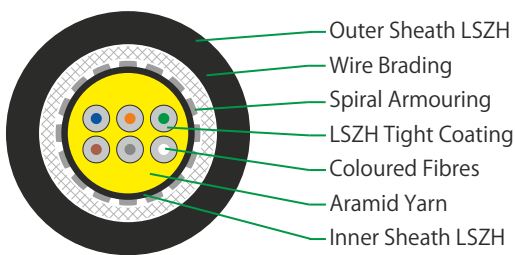

Cable Construction Details

- Tight Coating [Tight Buffer].
- Peripheral Strength member.
- Inner Sheath LSZH.
- Steel Wire Spiral Armoring.
- Steel Wire Brading.
- LSZH Outer sheath.

Technical Characteristics

FIBRE COUNT	TIGHT BUFFER DIAMETER (µm)Nominal	DIAMETER (mm) Nominal	WEIGHT (Kg./Km) Nominal	TENSILE STRENGTH (N)		BENDING RADIUS (mm)		TEMPERATURE RANGE (IEC 60794-1-2-F1)	
				Installation	Operation	Installation	Operation	Installation	Operation
up to 6	900	6.3	75	500	300	10D	20D	-20°C to +70°C	-20°C to +70°C

Tight Buffer Colour Coding

Natural or as per Customer Require EIA 359-A, IEC Publication 304(4) TIA 598D, IEC TR 63194 Latest Issue

Fiber Colour Coding



Special Features

- Lower Latency.
- Longer Distance Reach.
- Flexible.
- Light Weight.
- Mechanical Protection.
- Rodent and Pest Protection.

Mechanical Characteristics

Impact Resistance (Nm) [IEC 60794-1-2-E4]	Height 0.5 meters, Weight = 1 Kg, 3 nos at different places
Crush Resistance (N) [IEC 60794-1-2-E3]	3000 N [100 X 100 mm] for 5 minutes, 3 times at 150 mm apart
Repeated Bending [IEC 60794-1-2-E6]	30 Cycle, r = 20 X D, 1 Kg Load, D = Cable Diameter
Flame Test [IEC 60332-3-24]	Complied

Drum Length

2000/ 4000meters ± 5%

2F - 6F SINGLE SHEATH SPIRAL ARMoured OPTICAL FIBRE CABLE



Applications

- To provide high-speed, low-latency and reliable connectivity between the cellular base stations and the remote radio heads (RRHs) or antennas.
- Wireless telecommunications networks.



Typical Cross section of 4F

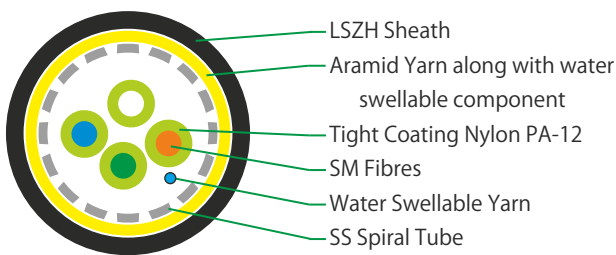

Cable Construction Details

- Tight Coating [Tight Buffer] Nylon.
- Steel Wire Spiral Armoring.
- Peripheral Strength member.
- LSZH Outer sheath.

Technical Characteristics

FIBRE COUNT	TIGHT BUFFER DIAMETER (µm)Nominal	DIAMETER (mm) Nominal	WEIGHT (Kg./Km) Nominal	TENSILE STRENGTH (N)		BENDING RADIUS (mm)		TEMPERATURE RANGE (IEC 60794-1-2-F1)	
				Installation	Operation	Installation	Operation	Installation	Operation
2	600	4.8	30	500	300	10D	20D	-20°C to +70°C	-20°C to +70°C
4	600	5.7	47	450	300	10D	20D	-20°C to +70°C	-20°C to +70°C
6	600	6.0	51	450	300	10D	20D	-20°C to +70°C	-20°C to +70°C

Tight Buffer Color Coding

Natural

Fiber Color Coding



Special Features

- Lower Latency
- Longer Distance Reach
- Flexible
- Light Weight
- Mechanical Protection
- Rodent and Pest Protection

Mechanical Characteristics

Impact Resistance (Nm) [IEC 60794-1-2-E4]	Height 0.5 meters, Weight = 1 Kg, 10 nos at different places
Crush Resistance (N) [IEC 60794-1-2-E3]	2000 N [100 X 100 mm] for 5 minutes, 3 times at 150 mm apart
Water Penetration [IEC 60794-1-2-F5 B]	1 Meter Water Head, 3 Meters Cable Sample, 24 Hours

Drum Length

2000/ 4000meters ± 5%

SINGLE SHEATH SPIRAL FURCATION TUBE CABLE



Applications

- To protect the bare or tight buffered optical fibers and to allow them to be terminated with connectors.



Typical Cross section

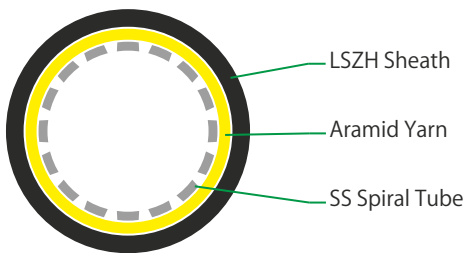

Cable Construction Details

- Stainless Steel Spiral tube.
- Aramid Yarn.
- LSZH Sheath, Black Colour.

Technical Characteristics

DIAMETER (mm)	WEIGHT (Kg./Km)	TENSILE STRENGTH (N)		BENDING RADIUS (mm)		TEMPERATURE RANGE (IEC 60794-1-2-F1)	
		Installation	Operation	Installation	Operation	Installation	Operation
4.8	30	450	300	15D	20D	-20°C to +70°C	-20°C to +70°C
2.75	12	250	170	15D	20D	-20°C to +70°C	-20°C to +70°C

Special Features

- Mechanical Protection.
- Flexibility.
- Rodent and Pest Protection.
- Environmental Protection.

Mechanical Characteristics

Kink Resistance (mm)
[IEC 60794-1-2-E10] 15 x D, D = Cable Diameter

Impact Resistance (Nm)
[IEC 60794-1-2-E4] Height 0.5 meters,
Weight = 0.5 Kg, 3 Nos

Crush Resistance (N)
[IEC 60794-1-2-E3] 500 N/ 10cm

Drum Length

2000/ 4000meters ± 5%

STAINLESS STEEL WIRE ARMoured TACTICAL CABLE FOR MILITARY APPLICATION

Tactical Optical Fibre Cables

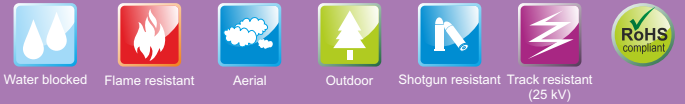

Applications

- Indoor/Outdoor
- Suitable for rapid deployment in extreme environmental conditions.
- Formilitary application
- Temporary robust communication lines and mobile applications with Rodent protection



Typical Cross section of 4 Fibre

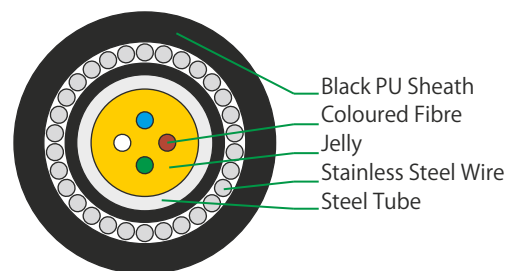
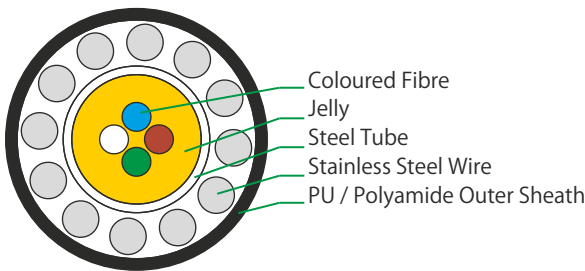

Technical Characteristics

FIBRE COUNT	DIAMETER SHEATH	WEIGHT (mm) Max.	(Kg./Km) Nominal	BENDING RADIUS (mm)		TEMPERATURE RANGE (IEC 60794-1-2-F1)	
				Installation	Operation	Installation	Operation
UPTO 6F	Double Sheath	6.0	70	15D	20D	-10° to +50° C	-40° to +70° C
12F	Double Sheath	7.0	95	15D	20D	-10° to +50° C	-40° to +70° C
UPTO 6F	Single Sheath	6.0	45	15D	20D	-10° to +50° C	-40° to +70° C

Color Coding - Fibre & Tube



Special Features

- Cut resistant, Polyurethane outer jacket
- Flexible construction for multiple deployment
- Performance in wide temp range
- High permissible tensile strength
- Excellent protection against rodents and termites
- Durable in high traffic areas
- Ruggedized cable and easy to use in the field
- High impact and crush resistance

Mechanical Characteristics

Tensile Strength Permanent	900 N max.
Crush Strength	1000 N/cm
Impact Resistance	200 (Min.)
Flex Resistance	2000 Cycle (Min.)
Storage Temperature	-30° C to +65° C
Breaking Load	>3500 N
Water Pressure	>500 Bar

Drum Length

500/ 1000/ 2000 meters ± 5%

2F-96F SINGLE SHEATH ULTRA LIGHT WEIGHT COMPACT FIBRE UNIT OPTICAL FIBRE CABLE



Applications

- This Cable is suitable for FTTH Roll out and a range of light weight drop type design / construction cables for installation in the Fibre Network in Overhead and Underground environments.
- This cable meets the breaking load requirement between 1350 N to 2000 N in the interests of safety for overhead applications. It benefits from unique safety features of predictable breaking load which is essential in the event of vehicle strike, to protect equipment and minimize the risk of loss of tangible assets that could potentially harm personnel, property or equipment and will be a fully safe aerial installation solution. Span length of 55 meters maximum.

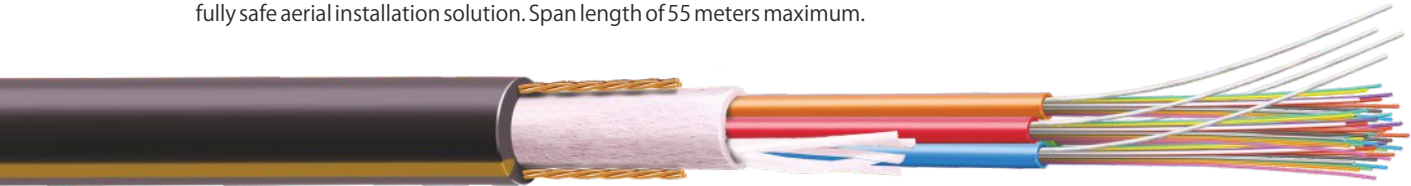

Typical Cross section of 48 Fibres

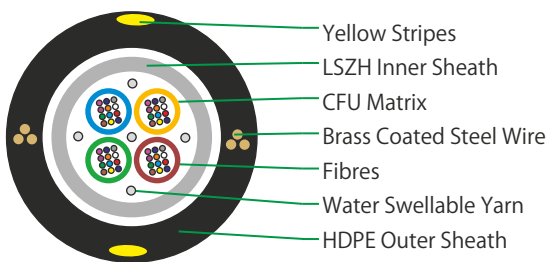

Cable Construction Details

- The CFU units consist of groups of fibres.
- The CFU are surrounded with water swelling elements to protect against moisture ingress.
- Inner Sheath of HFFR, Black Colour.
- Embedded strength members protect from against buckling.
- Outer Sheath of HDPE, UV Stabilized, Black Colour.

Technical Characteristics

FIBRE COUNT	DIAMETER (mm) Nominal	WEIGHT (Kg./Km) Nominal	TENSILE STRENGTH (N)		BENDING RADIUS (mm)		TEMPERATURE RANGE (IEC 60794-1-2-F1)	
			Installation	Operation	Installation	Operation	Installation	Operation
4F	7.0	38	950	500	10D	12D	-40°C to +60°C	-40°C to +60°C
12F	7.2	38	950	500	10D	12D	-40°C to +60°C	-40°C to +60°C
24F	7.2	38	950	500	10D	12D	-40°C to +60°C	-40°C to +60°C
36F	7.2	38	950	500	10D	12D	-40°C to +60°C	-40°C to +60°C
48F	7.2	38	950	500	10D	12D	-40°C to +60°C	-40°C to +60°C
72F	7.1	38	950	500	10D	12D	-40°C to +60°C	-40°C to +60°C
96F	7.1	38	950	500	10D	12D	-40°C to +60°C	-40°C to +60°C

CFU Color coding

Natural
We provide contrast dot marking on CFU

Fibre Colour Coding



- For Fibre Count 12F We provide the above colour code
- For Higher Fibre count We provide contrast dot marking of above colour code

Special Features

- Reduced diameter CFUs manufactured from soft and flexible elastomeric material.
- Diametrically opposed embedded strength members provides excellent crush protection and Tensile performance.
- CFUs are kink resistant and easily removed without the need for tools.
- Ultra-compactness, easier storage and faster installation.
- UV protected.

Mechanical Characteristics

Kink Resistance (mm) [IEC 60794-1-2-E10]	10 x D, D = Cable Diameter
Impact Resistance (Nm) [IEC 60794-1-2-E4]	10 Nm, Number of Impact 1, No. of Location: 3 at 100 mm apart.
Crush Resistance (N) [IEC 60794-1-2-E3]	2000 N [100 X 100 mm] for 10 minutes, Total number of applied load: 3 at 250 mm apart
Torsion Resistance [IEC 60794-1-2-E7]	5 Cycle [± 180°] 100 N Weight, Length under Test 1 meters
Water Penetration [IEC 60794-1-22-F5 B]	Water Head 1 m, 3 Meters Cable Sample, 24 Hours

Drum Length

2000/ 4000meters ± 5%

12F - 144F SINGLE SHEATH RETRACTABLE OPTICAL FIBRE CABLE WITH RIDGE

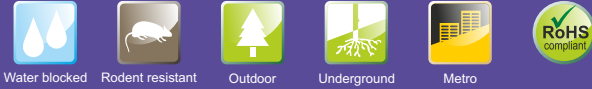

Applications

- These cables can be used for indoor installation.
- Window cuts into the sheath allow easy selection and extraction of single fibre unit for re-routing purposes without the need to dispose of excess cable
- Modules may be further blown, pushed or pulled (using pulling cords) inside micro-ducts.



Typical Cross section of 144 Fibre

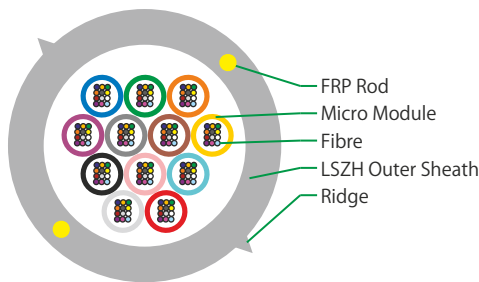

Cable Construction Details

- The micro-module unit consist of 12 fibres, an easily strippable and flexible
- Non-metallic and anti-buckling element FRP rod (2 nos) used as Embedded Strength Member
- LSZH Outer sheath

Technical Characteristics

FIBRE COUNT	DIAMETER (mm) Nominal	WEIGHT (Kg./Km) Nominal	TENSILE STRENGTH (N)		BENDING RADIUS (mm)		TEMPERATURE RANGE (IEC 60794-1-2-F1)	
			Installation	Operation	Installation	Operation	Installation	Operation
12F	≤ 6.0	≤ 26	500	300	15D	20D	-5°C to +60°C	-20°C to +60°C
24F	≤ 7.0	≤ 35	500	300	15D	20D	-5°C to +60°C	-20°C to +60°C
36F	≤ 8.0	≤ 46	500	300	15D	20D	-5°C to +60°C	-20°C to +60°C
48F	≤ 9.5	≤ 65	500	300	15D	20D	-5°C to +60°C	-20°C to +60°C
72F	≤ 10.0	≤ 72	500	300	15D	20D	-5°C to +60°C	-20°C to +60°C
96F	≤ 10.5	≤ 80	500	300	15D	20D	-5°C to +60°C	-20°C to +60°C
144F	≤ 12.0	≤ 98	500	300	15D	20D	-5°C to +60°C	-20°C to +60°C

Fiber Color Coding



Micro Module Color Coding



For Fiber Count 12F We provide the above color code

Special Features

- Low-bend-sensitivity fibre provides high bandwidth and excellent communication transmission property
- Two parallel strength members ensure good performance of crush resistance to protect the fibre
- Simple structure, light weight and high practicability
- All dielectric construction.

Mechanical Characteristics

Impact Resistance [IEC 60794-1-2-E4]	3 Nm, 3 Impacts at different places 500 mm apart
Repeated Bending [IEC 60794-1-2-E6]	25 Cycle, r = 20 X D, 20 N Load, D = Cable Diameter
Crush Resistance [IEC 60794-1-2-E3]	1000 N [100 X 100 mm] for 30 sec
Torsion Resistance [IEC 60794-1-2-E7]	10 Cycle [± 180°] 20 N Weight, Length under Test: 1 meters
Micro Module Strip-ability	1 meter in 1 minutes

Drum Length

2000/ 4000 meters ± 5%

2F-48F SINGLE SHEATH FAN OUT TIGHT BUFFERED UNARMoured OPTICAL FIBRE CABLE



Applications

- These cables are specifically designed for indoor/outdoor applications.
- Mainly used in intra-building backbones.
- Routing between telecommunications rooms and as a riser cable in Multi-Storey buildings.



Typical Cross section of 24 Fibre

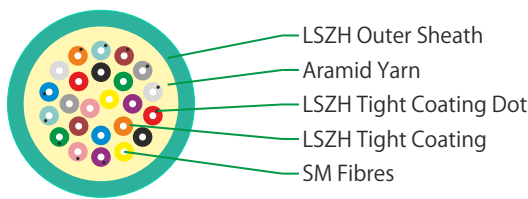

Cable Construction Details

- LSZH Tight Buffer.
- High Modulus, Aramid yarn as strength member below inner sheath.
- UV Stabilized, LSZH Outer sheath, black.

Technical Characteristics

FIBRE COUNT	TIGHT BUFFER DIAMETER (µm)Nominal	DIAMETER (mm) Nominal	WEIGHT (Kg./Km) Nominal	TENSILE STRENGTH (N)		BENDING RADIUS (mm)		TEMPERATURE RANGE (IEC 60794-1-2-F1)	
				Installation	Operation	Installation	Operation	Installation	Operation
2	900	4.8	20	800	500	10D	20D	-5°C to +60°C	-40°C to +70°C
4	900	5.2	24	800	500	10D	20D	-5°C to +60°C	-40°C to +70°C
6	900	5.7	28	800	500	10D	20D	-5°C to +60°C	-40°C to +70°C
8	900	6.2	32	800	500	10D	20D	-5°C to +60°C	-40°C to +70°C
12	900	7.0	42	800	500	10D	20D	-5°C to +60°C	-40°C to +70°C
16	900	7.5	48	1000	600	10D	20D	-5°C to +60°C	-40°C to +70°C
24	900	8.8	65	1500	700	10D	20D	-5°C to +60°C	-40°C to +70°C
32	900	9.5	72	1500	700	10D	20D	-5°C to +60°C	-40°C to +70°C
36	900	9.8	78	1700	800	10D	20D	-5°C to +60°C	-40°C to +70°C
48	900	10.8	94	2000	1000	10D	20D	-5°C to +60°C	-40°C to +70°C

Fiber & Micro Module Color Coding



- For Fiber Count 12F We provide the above colour code.
- For Higher Fiber count we provide contrast dot marking of above colour code.

Special Features

- 9900 Microns Tight buffered fibres support fast field installations.
- Reduce installation time and costs.
- Easy jacket removal using standard tools.
- Flexible and Fire retardant Inner & outer sheath with aramid yarns and Glass Yarn as tensile elements helps in easy installation in space constrained areas.
- LSZH sheath makes cable suitable for higher fire safety requirement.
- Small cable diameter & lightweight.
- Requires no grounding or bonding due to all-dielectric construction.

Mechanical Characteristics

Kink Resistance (mm) [IEC 60794-1-2-E10]	10 x D, D = Cable Diameter
Impact Resistance (Nm) [IEC 60794-1-2-E4]	Height 0.5 meters, Weight = 0.5 Kg, 3 Nos
Crush Resistance (N) [IEC 60794-1-2-E3]	500 N [100 X 100 mm] for 60 sec
Torsion Resistance [IEC 60794-1-2-E7]	10 Cycle [± 180°] 1 Kg Weight, Length under Test-2 meters
Repeated Bending [IEC 60794-1-2-E6]	30 Cycle, r = 20 X D, 1 Kg Load, D = Cable Diameter

Drum Length

2000/ 4000meters ± 5%

6F-48F DOUBLE SHEATH FAN OUT ECCS TAPE ARMoured OPTICAL FIBRE CABLE



Applications

- The universal design is suited for use in most network arenas, including backbone, access and distribution..
- Quick fibre preparation ready for installation.
- Installation within ducts using blown on pulling techniques.

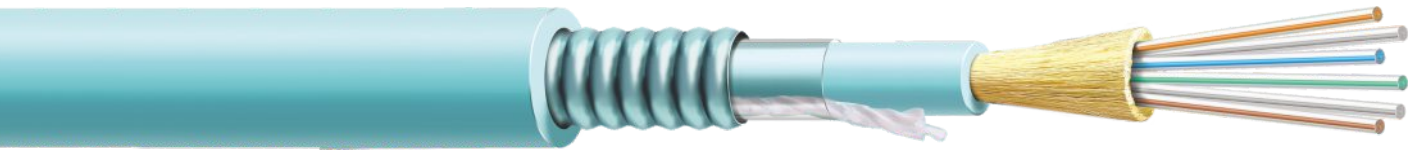

Typical Cross section of 12 Fibre

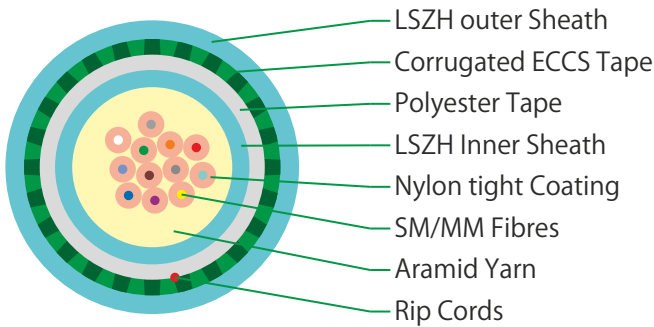

Cable Construction Details

- Tight Buffer Nylon.
- High Modulus, Aramid yarn as peripheral strength member.
- The Tight buffer unit consist of single fibre an easily strippable and flexible.
- LSZH inner sheath.
- Corrugated ECCS tape armour.
- LSZH outer sheath.

Technical Characteristics

FIBRE COUNT	TIGHT BUFFER DIAMETER (µm)Nominal	DIAMETER (mm) Nominal	WEIGHT (Kg./Km) Nominal	TENSILE STRENGTH (N)		BENDING RADIUS (mm)		TEMPERATURE RANGE (IEC 60794-1-2-F1)	
				Installation	Operation	Installation	Operation	Installation	Operation
6	900	10.5	120	1200	700	10D	20D	-15°C to +60°C	-15°C to +70°C
12	900	11.5	140	1400	750	10D	20D	-15°C to +60°C	-15°C to +70°C
24	900	13.4	195	2400	1200	10D	20D	-15°C to +60°C	-15°C to +70°C
48	900	15.6	245	2700	1500	10D	20D	-15°C to +60°C	-15°C to +70°C

Fiber & Micro Module Colour Coding



For Fibre Count 12F We provide the above colour code
For Higher Fibre count we provide contrast dot marking of above colour code

Special Features

- Reduced diameter.
- Armour provides excellent crush performance.

Mechanical Characteristics

Kink Resistance (mm) [IEC 60794-1-2-E10]	10 x D, D = Cable Diameter
Impact Resistance (Nm) [IEC 60794-1-2-E4]	Height 0.5 meters, Weight = 1 Kg, 3 Nos
Crush Resistance (N) [IEC 60794-1-2-E3]	1000 [100 X 100 mm] for 60 sec
Torsion Resistance [IEC 60794-1-2-E7]	10 Cycle, ± 180°, Length under Test 2 meters
Repeated Bending [IEC 60794-1-2-E6]	25 Cycle, r = 20 X D, D = Cable Diameter

Drum Length

2000/ 4000meters ± 5%

6F-48F DOUBLE SHEATH FAN OUT WITH GLASS YARN ARMoured DIELECTRIC OPTICAL FIBRE CABLE



Applications

- These cables are specifically designed for indoor/outdoor applications.
- Mainly used in intra-building backbones.
- Routing between telecommunications rooms and as a riser cable in Multi-Storey buildings.



Typical Cross section of 24 Fibre

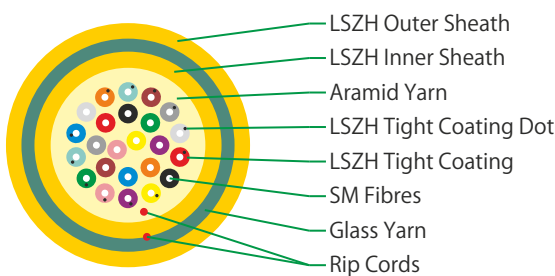

Cable Construction Details

- TLSZH Tight Buffer.
- High Modulus, Aramid yarn as strength member below inner sheath.
- LSZH Inner sheath, black.
- Peripheral Strength Member as Glass Yarn below outer sheath.
- LSZH Outer sheath, black.

Technical Characteristics

FIBRE COUNT	TIGHT BUFFER DIAMETER (µm)Nominal	DIAMETER (mm) Nominal	WEIGHT (Kg./Km) Nominal	TENSILE STRENGTH (N)		BENDING RADIUS (mm)		TEMPERATURE RANGE (IEC 60794-1-2-F1)	
				Installation	Operation	Installation	Operation	Installation	Operation
6	900	9.2	94	2000	800	10D	15D	-10°C to +60°C	-20°C to +70°C
12	900	10.4	120	3000	1000	10D	15D	-10°C to +60°C	-20°C to +70°C
24	900	12.5	165	3000	1000	10D	15D	-10°C to +60°C	-20°C to +70°C
48	900	14.8	225	3000	1000	10D	15D	-10°C to +60°C	-20°C to +70°C

Fibre & Micro Module Colour Coding



- For Fiber Count 12F We provide the above colour code.
- For Higher Fiber count we provide contrast dot marking of above colour code

Special Features

- 900 Microns Tight buffered fibres support fast field installations.
- Easy jacket removal using standard tools.
- Reduce installation time and costs.
- Flexible and Fire retardant Inner & outer sheath with aramid yarns and Glass Yarn as tensile elements helps in easy installation in space constrained areas.
- LSZH sheath makes cable suitable for higher fire safety requirement.
- Small cable diameter & lightweight.
- Requires no grounding or bonding due to all-dielectric construction.

Mechanical Characteristics

Kink Resistance (mm) [IEC 60794-1-2-E10]	10 x D, D = Cable Diameter
Impact Resistance (Nm) [IEC 60794-1-2-E4]	1500 Impacts
Crush Resistance (N) [IEC 60794-1-2-E3]	1000 N [100 X 100 mm] for 60 sec
Water Penetration [IEC 60794-1-2-F5 B]	1 Meter Water Head, 3 Meters Cable Sample, 24 Hours [on Inner Sheath]
Flame test [IEC 60332-1-2]	Complied

Drum Length

2000/ 4000meters ± 5%

**1F-4F FRP EMBEDDED
FLAT DROP INDOOR OPTICAL FIBRE CABLE**

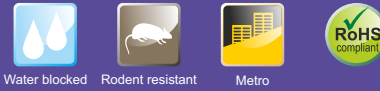

Applications

Suitable for Indoor drop application



Typical Cross section

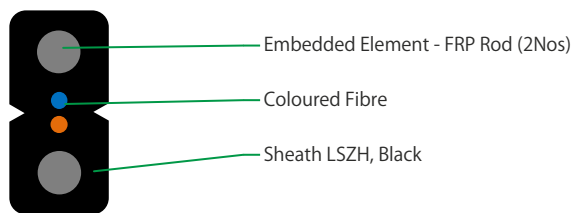

Cable Construction Details

- Up to 4 enhance low water peak single mode fibres in full compliance with ITU-T-G.652D (also available with G.657A1 & G.657A2)
- Outer sheath LSZH, Black
- FRP Embedded in outer sheath as strength member.

Technical Characteristics

FIBRE COUNT	DIAMENTION (mm) Nominal	WEIGHT (Kg./Km) Nominal	TENSILE STRENGTH (N)		BENDING RADIUS (mm)		TEMPERATURE RANGE (IEC 60794-1-2-F1)	
			Installation	Operation	Installation	Operation	Installation	Operation
1	2.0 X 3.0	9.0	100	50	10D	20D	-10°C to +50°C	-40°C to +70°C
2	2.0 X 3.0	9.0	100	50	10D	20D	-10°C to +50°C	-40°C to +70°C
4	2.0 X 3.0	9.0	100	50	10D	20D	-10°C to +50°C	-40°C to +70°C

Fibre colour coding

Without ring mark



Special Features

- Completely dielectric cable/ non metallic cable immune to electromagnetic interferences.
- Small size and Diamention for easy to strip.
- Easy access to the fibres.
- Quick cable entry & easy to peel.
- Low insertion and back reflection loss.
- Good durability.
- High temprature stability.
- Clean, gel free, Dry design

Mechanical Characteristics

Cable Bending Radius (mm) [IEC 60794-1-21-E11 A & B]	20 X D, D= Cable diameter
Impact Resistance (Nm) [IEC 60794-1-21-E4]	1 Nm, 1 Impacts
Crush Resistance (N) [IEC 60794-1-21-E3A]	500 N/ (100 X 100 mm)
Torsion Resistance [IEC 60794-1-21-E7]	5 Cycle (± 180°)

Drum Length

1000/ 2000 meters ± 5%

**2F-24F SINGLE SHETH UNI-TUBE
MICRO OPTICAL FIBRE CABLE**



Applications

- Suitable for Indoor application.
- Suitable for micro duct installation.



Typical Cross section of 24 Fibre

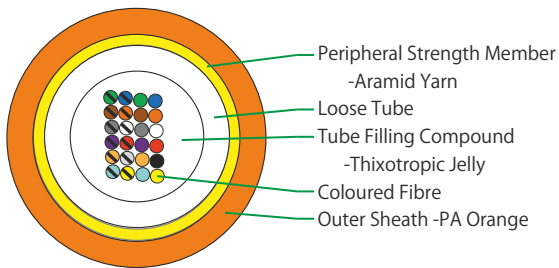

Cable Construction Details

- 1.Up to 24 enhance low water peak single mode fibres in full compliance with ITU-T-G.652D (also available with G.657A1 & G.657A2)
- Loose buffer tubes fully filled with Thixotropic Jelly & Fibers.
- Aramid yarn as flexible strength member.
- Outer sheath, Nylon Orange (Also available with HDPE)

Technical Characteristics

FIBRE COUNT	DIAMETER (mm) Nominal	WEIGHT (Kg./Km) Nominal	TENSILE STRENGTH (N)		BENDING RADIUS (mm)		TEMPERATURE RANGE (IEC 60794-1-2-F1)	
			Installation	Operation	Installation	Operation	Installation	Operation
With Nylon Sheath								
2F-12F	2.5	6.0	250 N	100 N	10D	20D	-10°C to +50°C	-40°C to +70°C
24F	3.5	11.0	250 N	100 N	10D	20D	-10°C to +50°C	-40°C to +70°C
With HDPE Sheath								
2F-12F	3.5	10.0	300 N	150 N	10D	20D	-10°C to +50°C	-40°C to +70°C
24F	4.0	13.0	300 N	150 N	10D	20D	-10°C to +50°C	-40°C to +70°C
Nylon Sheath With 200 Micron (ITU-T G.657A1 & G.657A2)								
2F-12F	2.5	10.0	100 N	50 N	10D	20D	-10°C to +50°C	-20°C to +70°C

Fiber Color Coding Without ring mark



Fiber Color Coding With ring mark



More than 12F We provide Black ring mark over colored fibre

Special Features

- Completely dielectric cable/ non metallic cable immune to electromagnetic interferences.

Drum Length

2000/ 4000 meters ± 5%

Mechanical Characteristics

Cable Bending Radius (mm) [IEC 60794-1-21-E11 A & B]	20 X D, D= Cable diameter
Impact Resistance (Nm) [IEC 60794-1-21-E4]	1 Nm, 1 Impacts
Crush Resistance (N) [IEC 60794-1-21-E3A]	100 N/ (100 X 100 mm)
Torsion Resistance [IEC 60794-1-21-E7]	2 Cycle (± 180°)

2F-48F FANOUT TIGHT BUFFER UNARMoured OPTICAL FIBRE CABLE



Indoor



Metro



Flame resistant



RoHS compliant

Applications

- Rugged multi fibre cross connect
- Intra building backbone
- Fibre backbone to communication closets



Typical Cross Section of 2F

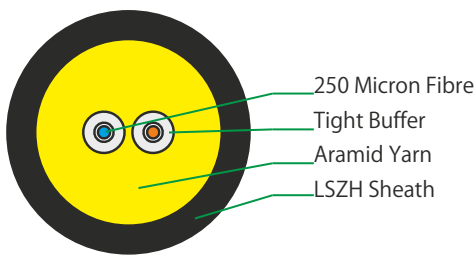

Cable Construction Details

- Upto 48 Fibre of Single mode fibre in full compliance with ITU-T G652D (also available with G657 SM Fibre and OM1 / OM2 / OM3 & OM4 MM Fibre)
- Aramid Yarns as Strength Member
- PA-12 / LSZH tight coating on Fibre
- LSZH Compound for outer sheathing

FIBRE COUNT	DIAMETER (mm) Nominal	WEIGHT (Kg./Km) Nominal	TENSILE STRENGTH (N)		BENDING RADIUS (mm)		TEMPERATURE RANGE (IEC 60794-1-2-F1)	
			Installation	Operation	Installation	Operation	Installation	Operation
UPTO 6F	5.0	25	500	300	15D	20D	-10° to +70° C	-40° to +70° C
8/12F	6.8	32	500	300	15D	20D	-10° to +70° C	-40° to +70° C
36/48F	16.5	215	2000	1000	15D	20D	-10° to +70° C	-40° to +70° C

Color Coding - Fibre



* For Fibre count more than 12F, bundles in multiple of 9/12F will be formed with color identification binder (Blue, Orange, Green & Brown)

Special Features

- Tight buffer & jacket are available in variety of colours.
- Easy access to the fibres
- Quick Cable Entry

Mechanical Characteristics

Torsion Resistance [IEC 60794-1-2-E7]	2 Cycle (± 360°) 1 Kg Weight, L= 2 Mtr
Crush Resistance [IEC 60794-1-2-E3]	1000 N (100 X 100 mm) for 600 sec

Drum Length

1000 meters ± 10%

2F-16F BREAKOUT TIGHT BUFFER UNARMOURED OPTICAL FIBRE CABLE



Indoor



Metro



Flame resistant



RoHS compliant

Applications

- Rugged multi fibre cross connect
- Intra building backbone
- Fibre backbone to communication closets

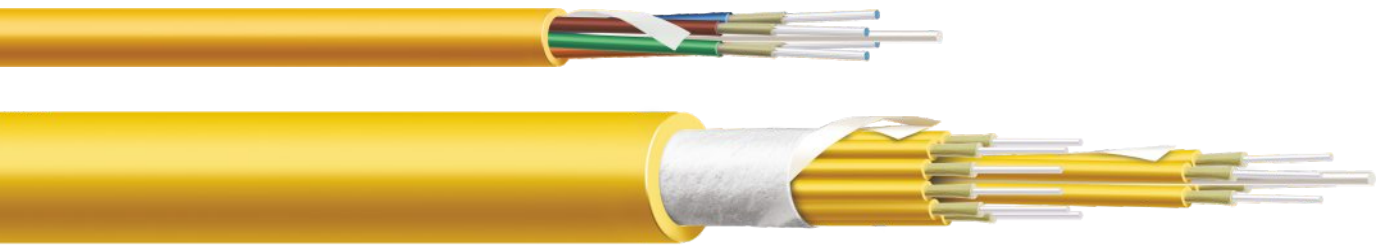

Typical Cross Section of 8F

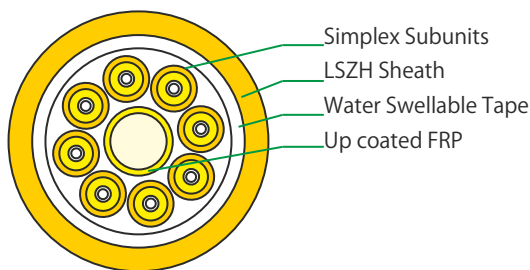

Cable Construction Details

- 4/6/8/12/16 Fibre of Single mode fibre in full compliance with ITU-TG652D (also available with G657 SM Fibre and OM1 / OM2 / OM3 & OM4 MM Fibre)
- FRP and Aramid Yarns as Strength Member
- PA-12 tight coating on Fibre
- LSZH Compound for sheathing for simplex subunits & outer sheath of cable

FIBRE COUNT	DIAMETER (mm) Nominal	WEIGHT (Kg./Km) Nominal	TENSILE STRENGTH (N)		BENDING RADIUS (mm)		TEMPERATURE RANGE (IEC 60794-1-2-F1)	
			Installation	Operation	Installation	Operation	Installation	Operation
4F	8.0	60	800	400	15D	20D	-20° to +70° C	-40° to +70° C
6F	9.0	79	800	400	15D	20D	-20° to +70° C	-40° to +70° C
8F	10.2	95	800	400	15D	20D	-20° to +70° C	-40° to +70° C
12F	12.0	120	800	400	15D	20D	-20° to +70° C	-40° to +70° C
16F	13.5	160	800	400	15D	20D	-20° to +70° C	-40° to +70° C

Special Features

- Individual cores are printed at every 200 mm for identification
- Tight buffer & simplex jacket are available in variety of colours.
- Easy access to the fibres
- Quick Cable Entry

Mechanical Characteristics

Torsion Resistance [IEC 60794-1-2-E7]	2 Cycle (± 360°) 1 Kg Weight, L= 2 Mtr
Crush Resistance [IEC 60794-1-2-E3]	1000 N (100 X 100 mm) for 60 sec
Kink Resistance [IEC 60794-1-2-E10]	15 x D, D = Cable D

Drum Length

1000 meters ± 10%

INTERCONNECT CABLES



Indoor



Metro



Flame resistant



RoHS compliant

Applications

- Communication racks and wiring closets, walls, ceilings, floor ducts, etc
- In the final connection to terminal devices such as workstation and computer terminals for high speed voice, video, data, and FTTx applications
- Short run office & computer room cabling
- Patch cords, Pigtails & Jumpers

Typical Cross Section of Simplex

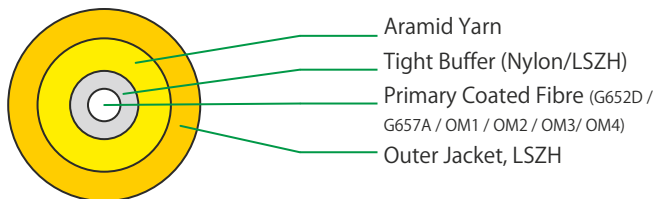

- Aramid Yarn
- Tight Buffer (Nylon/LSZH)
- Primary Coated Fibre (G652D / G657A / OM1 / OM2 / OM3 / OM4)
- Outer Jacket, LSZH

Cable Construction Details - Simplex

A single optical fibre is tight buffered and surrounded by aramid yarn strength member and jacketed with riser or plenum or LSZH grade jacketing to 2.0/3.0 mm diameter.



Typical Cross Section of Duplex

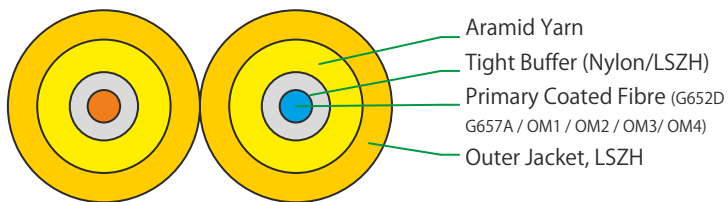

- Aramid Yarn
- Tight Buffer (Nylon/LSZH)
- Primary Coated Fibre (G652D / G657A / OM1 / OM2 / OM3 / OM4)
- Outer Jacket, LSZH

Cable Construction Details - Duplex

Two Simplex cables 2.0/3.0 mm are joined as a figure-8 design



Typical Cross Section of Flat Twin

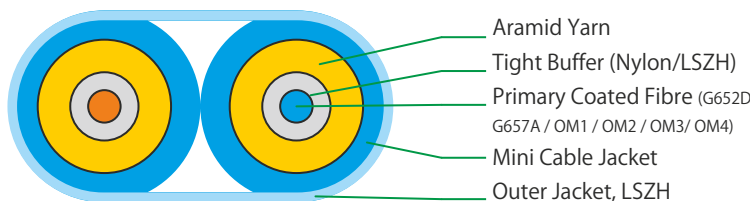

- Aramid Yarn
- Tight Buffer (Nylon/LSZH)
- Primary Coated Fibre (G652D / G657A / OM1 / OM2 / OM3 / OM4)
- Mini Cable Jacket
- Outer Jacket, LSZH

Cable Construction Details - Flat Twin

Duplex Zip cable (2.0/3.0 mm) is jacketed with riser, plenum or LSZH grade jacketing.



Drum Length

1000/ 2000 meters ± 5%



*Connections....
Unlimited*

Copper Telecommunications Cables

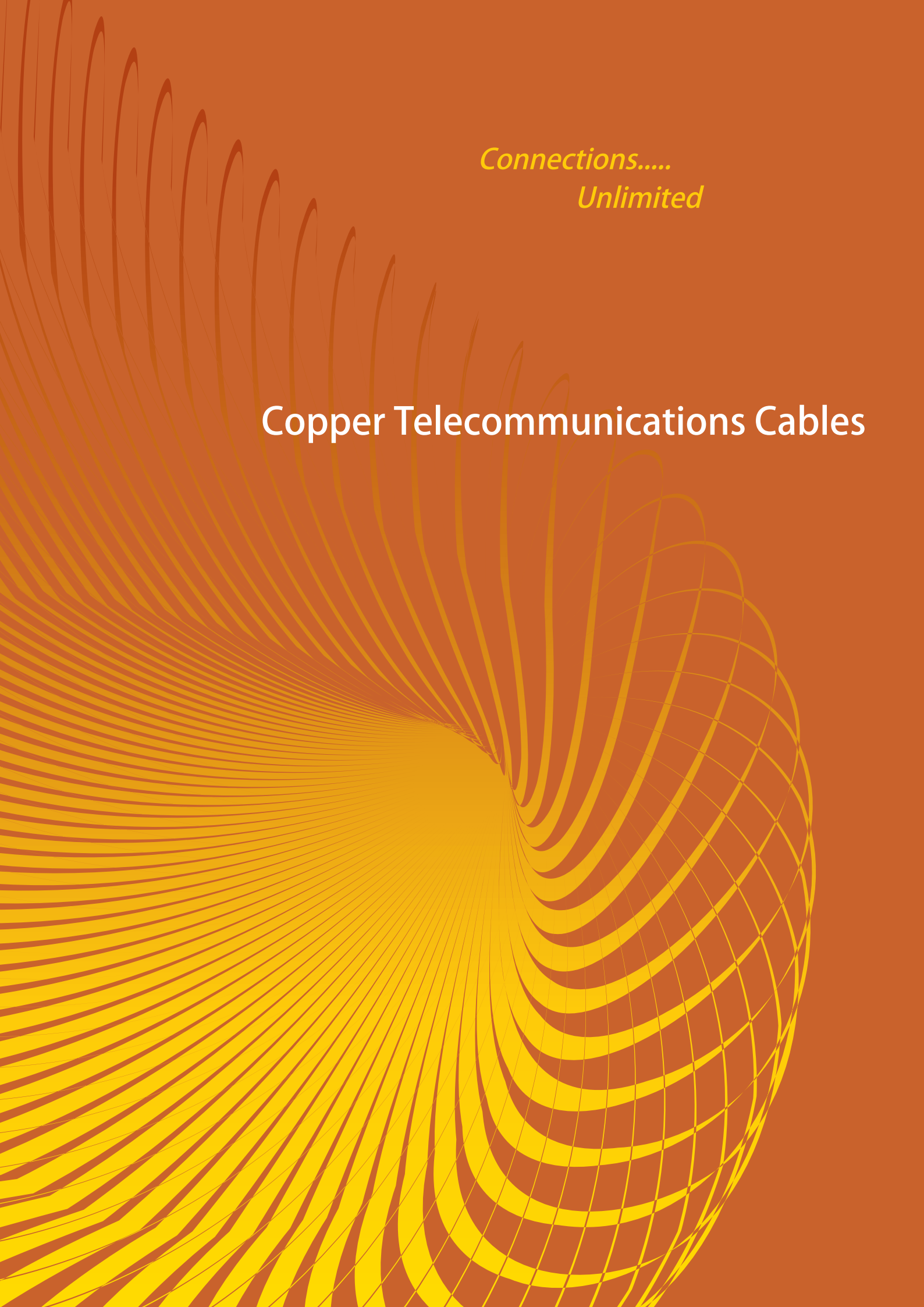

**FOAM SKIN / SOLID PE INSULATED
JELLY FILLED TELEPHONE CABLE**



Applications:

- Local distribution networks - Primary & Secondary
- Junction between exchanges



Typical Cross section for Armoured Cable

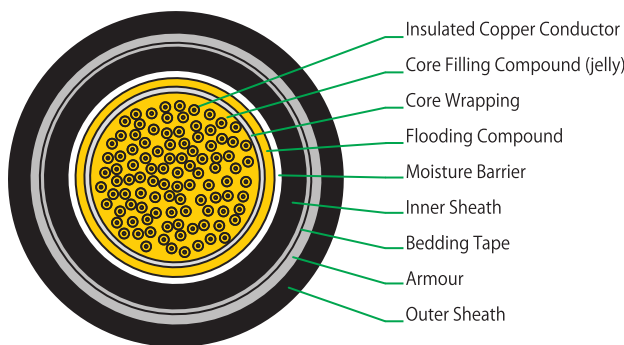

Features:

- Armoured & Unarmoured construction
- Availability of standard conductor sizes ranging from 0.4 mm to 0.9 mm diameter.
- Available in sizes up to 2400 pairs
- Suitable for installation in ducts
- Direct Burial application for armoured cable

Technical Details

Conductor Diameter	Conductor Resistance at 20°C (Solid or Foam Skin Cable)	Attenuation at 150KHz.
0.40 mm	135 ± 8 Ω/Km	12.00 dB/Km (max.avg.)
0.50 mm	86 ± 6 Ω/Km	8.25 dB/Km (max. avg.)
0.63 mm	58 ± 4 Ω/Km	6.30 dB/Km (max. avg.)
0.90 mm	28 ± 2 Ω/Km	4.40 dB/Km (max. avg.)

Mutual Capacitance	Capacitance Unbalance	
52 +/- 3 nF/Km (avg.)	Pair to Pair	Pair to Earth
52 +/- 4.5 nF/Km (individual)	50 pF/Km (Max. Avg.)	750 pF/Km (max. avg.)
	200 pF/Km (Max.)	3000 pF/Km (max.)

Insulation Resistance : 5000 mega ohms / Km (Min.)

ELFEXT :55 dB/Km (min) at 150 KHz	NEXT : 55 dB (min.) at 150 KHz.
67.8 dB/Km (RMS) at 150 KHz.	

Cable Construction Details

- Conductor** Conductor - Each conductor consists of a round wire of annealed high conductivity copper.
- Insulation** Each conductor is insulated with Foam Skin / Solid PE insulation. Foam Skin insulation consists of an extruded inner layer of uncoloured foam, covered by an extruded outer layer of coloured skin with required colours to meet the specification. For Solid insulation each conductor is insulated with Solid medium/high density polyethylene insulation.
- Twinning** Two insulated conductors are twisted with uniform lay to form a pair. The length of the lay of the pairs is so chosen that the cross talk is minimum.
- Units & Super Units** No's of twisted pairs are laid up to form a group which constitutes a unit.
- Stranding** Twisted pairs/ super units are stranded to form a cable core.
- Filling** The cable core is fully filled with water resistant compound which is compatible with the polythene insulation of the conductors.
- Core Wrapping & Screening** The filled cable core is wrapped with at least one helical or longitudinal plastic tape. Thereafter one aluminium tape, coated with copolymer on both sides is applied longitudinally over the cable core with a specified overlap.
- Sheathing** The screened cable core is sheathed with black polythene compound grade 03C as per BS:6234.
- Bedding tape** If the cable is required to be armoured, two helical lapping of polythene bedding tape is applied over the polythene sheath.
- Armouring** The cable is then armoured with two applications of galvanized steel tape each applied helically with a specified gap. The second tape covers the gap left by the first tape.
- Jacketing** The armoured cable is finally jacketed with black polythene compound grade 03C of BS:6234.

SELF SUPPORTING AERIAL (FIGURE 8 TYPE) TELEPHONE CABLE



Applications:

- Suitable for Aerial Installation
- Local distribution networks - Secondary networks



Typical Cross section for Armoured Cable

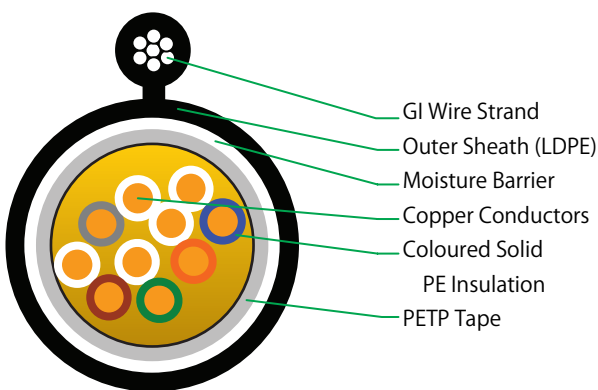

Features:

- Availability of standard conductor sizes of 0.4, 0.5, 0.6 & 0.9mm diameter
- Figure-8 construction
- Availability upto 200 pairs
- Suitable for installation in Hilly areas/areas where digging is not possible

Technical Details

Conductor Diameter	Conductor Resistance at 20°C (Solid or Foam Skin Cable)	Attenuation at 105KHz.
0.40 mm	135 ± 8 Ω/Km	12.00 dB/Km (max.avg.)
0.50 mm	86 ± 6 Ω/Km	8.25 dB/Km (max. avg.)
0.63 mm	58 ± 4 Ω/Km	6.30 dB/Km (max. avg.)
0.90 mm	28 ± 2 Ω/Km	4.40 dB/Km (max. avg.)

Mutual Capacitance	Capacitance Unbalance	
52 ± 3 nF/Km (avg.)	Pair to Pair	Pair to Earth
52 ± 4.5 nF/Km (individual)	50 pF/Km (Max. Avg.)	750 pF/Km (max. avg.)
	200 pF/Km (Max.)	3000 pF/Km (max.)

Insulation Resistance : 2500 mega ohms / Km (Min).

ELXT : 55 dB/Km (min)at 150 KHz	NEXT : 55 dB (min.) at 150 KHz.
67.8 dB/Km (RMS) at 150 KHz.	

Cable Construction Details

- Conductor** Each conductor consists of a round wire of annealed high conductivity copper.
- Insulation** Each conductor is insulated with solid medium/high density polyethylene insulation.
- Twining** Two insulated conductors are twisted with uniform lay to form a pair. The length of the lay of the pairs is so chosen that the cross-talk is minimum.
- Units & Super Units** 10 or 20 No's of twisted pairs are laid up to form a group which constitutes a unit. Each unit should have an overlapping for color ID. In case of cables having more than 100 pairs, 5 units of 10 pairs or 20 pairs are laid up to constitute 50 or 100 pairs of super units respectively.
- Stranding** For cable upto 20 pairs the required number of twisted pairs are stranded to form a cable core. For cables having 50 and 100 pairs, 5 numbers of 10 pair or 20 pair units are stranded to form 50 and 100 pair cables respectively. For cables having higher than 100 pairs, required number of super units are stranded to form a cable core.
- Core Wrapping & Screening** The cable core is wrapped with at least one helical or longitudinal plastic tape. Thereafter one aluminium tape ,coated with co-polymer on both sides is applied longitudinally over the cable core with a specified overlap. The tape is sealed and bonded to the inner surface of the polythene sheath.
- Suspension Wire /Strand** A Suspension Wire /Strand is provided.
- Sheathing** The screened cable core along with suspension wire as an integral part with the cable is sheathed with black polythene compound to form figure-8

UNDERGROUND JELLY FILLED QUAD CABLES



Applications

- Axle counter
- Signalling



Typical Cross section for Armoured Cable

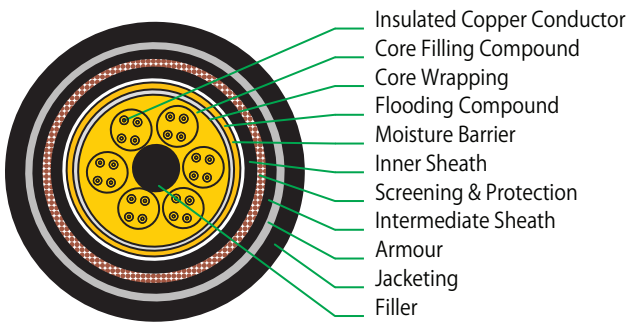

Cable Construction Details

- Conductor** Round wire of annealed high conductivity copper
- Insulation** Each conductor is insulated with solid PE
- Quadding** Four insulated conductors stranded to form a star quad.
- Laying Up** The quads are assembled to form a symmetrical core with a right hand lay. Polyethylene strings of required diameter may be used as fillers, if necessary.
- Filling & core wrapping** The cable core is fully filled with water -resistant compound and wrapped with polyethylene.
- Moisture Barrier** Aluminium tape coated with co-polymer on both sides is applied longitudinally over the cable core with a specified overlap.
- Sheathing** The screened cable core is sheathed with black polythene compound as per BS:6234.
- Screening & protection** The cable core with inner sheath is surrounded by a reasonably close fitted screen of Aluminium in the form of wires/ strips . The aluminium screen is wrapped with a single layer of woven tape impregnated with Barium chromate with overlap.
- Intermediate sheath** Further protection of screening is provided by extruded PVC/PE sheath over screening.
- Armouring** Armouring with two applications of Galvanized steel tape each applied helically with a specified gap.
- Jacketing** The armoured cable is finally jacketed with black PVC/PE compound.

Technical Details

Conductor Diameter	Conductor Resistance at 20°C	Attenuation at 20°C
0.90mm	28 (Each Core) Ω/Km (Max)	4.40 dB/Km (Max. Avg.) at 150KHz
	56 (loop) Ω/Km (Max)	
1.4mm	11.6 (Each Core) Ω/Km (Max)	2 dB/Km (Max. Avg.)at 300-3400 Hz
	23.2 (loop) Ω/Km (Max)	
	0.3 dB/Km (Max. Avg.) at 0.8KHz	
	0.8 dB/Km (Max. Avg.) at 5KHz	
	1.3 dB/Km (Max. Avg.) at 21KHz	
	2.5 dB/Km (Max. Avg.) at 150KHz	

Mutual Capacitance	Capacitance Unbalance (800 Hz to 1000 Hz)	
50 ± 2.5 nF/ Km (avg.)	Pair to Pair	Pair to Earth
50 ± 6 nF/Km (individual)	300 pF/Km (max.)	1500 pF/Km (max. avg.)

Insulation Resistance 5000 mega Ωs / Km (min.)

0.90 mm	ELFEXT : 150 KHz	NEXT : 55 dB (min.) at 150 KHz
	55 dB/Km Ind. (Min.)	
	67.8 dB/Km (RMS) (Min.)	
1.4 mm	ELFEXT : at 0.8KHz, 5KHz	NEXT : 55 dB (min.) at 0.8 KHz, 5 KHz, 21 KHz & 150 KHz
	21 KHz & 150 KHz	
	60.0 dB/Km Ind. (Min.)	
	70.8 dB/Km (RMS) (Min.)	

Reduction Factor (Field intensity of 50v to 450v) : 0.10 (Max)
Characteristic Impedance (Ω)

0.90 mm	470 +/- 15% Ω at 0.8KHz
	195 +/- 15% Ω at 5.0 KHz
1.4 mm	310 +/- 15% Ω at 0.8KHz
	150 +/- 15% Ω at 5.0 KHz
	110 +/- 15% Ω at 21.0 KHz
	100 +/- 15% Ω at 150.0 KHz

Color Coding for Quad :

- No1 - White, Orange, Red , Green
- No2 - White, Blue, Red , Green
- No3 - White, Brown, Red , Green
- No4 - White, Green, Red , Green
- No5 - White, Yellow, Red , Green
- No6 - White, Black, Red , Green

Features:

- Suitable for Direct burial application
- Armoured construction
- Availability of standard conductor sizes of 0.9 mm & 1.4 mm diameter.
- Available in 4 and 6 quads.
- Suitable for use on AC systems (earthed or unearthed) for rated voltage up to and including 1100 volts.
- These cables may be used on DC systems for rated voltages up to and including 1500 volts on earth.

SIGNALING CABLES



Applications

- Railway Signalling



Typical Cross section for Armoured Cable

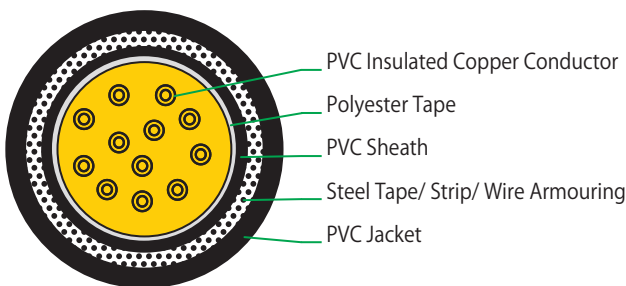

Cable Construction Details

Conductor Each conductor shall consist of a solid round/stranded wire(s) of annealed high conductivity copper, smoothly drawn, nominally circular in section, uniform in quality and resistance and free from defects.

Insulation Insulation shall be of PVC Compound conforming to requirements of Type-A compound of IS 5831:1984. Insulation color shall be as per customer specification.

Core Formation The insulated cores shall be laid up together with suitable lay. The outer most layer shall have right hand lay and the successive layers shall be laid with opposite lay. A polyester tape of suitable thickness shall be helically applied normally in cables with double steel tape with suitable overlap.

Inner Sheath The inner sheath shall be of PVC Compound conforming to requirements of Type- ST1 as per IS 5831:1984.

Armouring Armouring shall consist of the either Galvanised Round Wire strip/Double Steel Tape.

Jacket The outer sheath shall be of PVC Compound conforming to requirements of Type- ST1 as per IS 5831:1984.

Technical Details

Nominal Cross Sectional Area	No. of Wires in Conductors	Nom. Dia of Wire	Max. Resistance at 20°C		Nom. Thickness of Insulation	
			Single Core	Multi Core	Single Core	Multi Core
Sqmm	No(s)	mm	Ω/Km	Ω/Km	mm	mm
1.0	1	1.13	17.689	18.04	1.5	0.8
1.5	1	1.4	11.54	11.77	1.5	0.8
2.5	1	1.80	6.978	7.118	1.5	0.9
2.5	3	1.06	6.843	6.980	1.5	0.9
4	1	2.24	4.506	4.596	1.5	1.0
4	7	0.85	4.591	4.683	1.5	1.0
6	1	2.8	2.884	2.942	1.5	1.0
10	7	1.4	1.660	1.693	1.5	1.0
16	7	1.70	1.124	1.149	1.5	1.0
25	7	2.24	0.6484	0.6614	1.5	1.2
35	7	2.50	0.5205	0.5309	1.5	1.2
50	19	1.8	0.3706	0.3780	1.5	1.4

Insulation Resistance (M-Ω/Km) (Dry) (500 V DC for 1 Min. at 50° C)	10 M-Ω/Km upto 2.5 mm ² Conductor 5 M-Ω/Km More than 2.5 mm ² Conductor
Insulation Resistance (M-Ω/Km) (Wet) (500 V DC for 1 Min. at 50° C)	7.5 M-Ω/Km upto 2.5 mm ² Conductor 5 M-Ω/Km More than 2.5 mm ² Conductor
HV Test at Room Temp.	4 KV AC (rms) or 12 KV DC (for 5 Min.)

Features:

- Availability of conductor sizes ranging from 1.13 mm to 2.80 mm diameter. Cable size ranging from 2 core to 100 cores with 1.0 Sqmm to 50 Sqmm.
- Suitable for use on AC systems (Earthed or unearthed) for rated voltage upto 1100 volts
- Suitable for use on DC systems for rated voltage upto 1500 volts

JUMPER WIRE



Indoor



Outdoor



RoHS
compliant

Applications

- Indoor Telephone wiring & Signal distribution



Typical Cross section for Armoured Cable

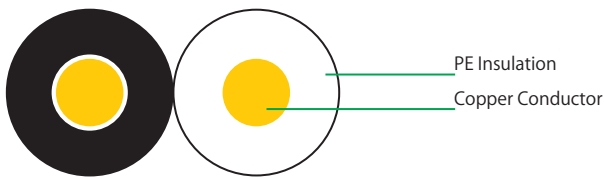

Cable Construction Details

- Conductor** Each conductor shall consist of a solid round wire of annealed high conductivity copper, smoothly drawn, nominally circular in section, uniform in quality and resistance and free from defects. The quality of copper shall confirm to IEC-28 or IS-12444.
- Insulation** Each conductor shall be insulated with solid polyethylene.
- Pairing** Two Insulated conductors shall be twisted together with uniform lay to form a pair.

Electrical Parameters At 20°C

For 0.50 mm Jumper Wire

Parameter	Limit	Tol.	Remarks
Resistance (Ω/Km)	89	+/- 4	
Re. Unbalance %	Ind 2.5 Ω/Km (Max.)		
Insulation Resistance	Min 500 (Ω/Km)		For 1 Minutes with 250-500 V DC
Dielectric Strength	10KVDC		For 3 Seconds

For 0.65 mm Jumper Wire

Parameter	Limit	Tol.	Remarks
Resistance (Ω/Km)	62	+/- 4	
Re. Unbalance %	Ind 2.5Ω/Km (Max.)		
Insulation Resistance	Min 500 (Ω/Km)		For 1 Minutes with 250-500 V DC
Dielectric Strength	10KVDC		For 3 Seconds

Length & Tolerance :

500 Mtrs.(± 5 %)

Packing :

In Coils, wrapped with polyethylene sheets, packed in Cartons or Plastic Reels

Colour Code For Conductor Insulation(*)

Cond. Size Insulation	Colour 1st Wire(Tip)	Colour 2nd Ring	Dia Over
0.50 mm	Black	White	1.40 mm (Nom.)
0.60 mm	Black	White	1.10 mm (Nom.)

(*) or as desired by the customer

ELECTROPLATED TINNED COPPER WIRE



Applications

- Copper wire armoring & soldering power sectors
- Screening applications in telecom & signaling cables



Data Sheet

A) Electroplated Tinned Wires Suitable for Drawing to Fine Wire [UN-ANNEALED]

WIRE SIZE	PARAMETER	SPECIFIED VALUES	UOM
2.80 mm	Diameter (Mom)	2.80	mm
	Tin Coating (Min)	As per Requirement*	Microns
	Persulphate Test	Should Pass	
WIRE SIZE	PARAMETER	SPECIFIED VALUES	UOM
1.60 mm	Diameter (Mom)	1.60	mm
	Tin Coating (Min)	As per Requirement*	Microns
	Persulphate Test	Should Pass	

*Depends on the Tin Coating Thickness required at finely Drawn Copper Wire

Above Sizes Shall be packed in Returnable MS Baskets.

B) Drawn Tinned Copper [ANNEALED]

WIRE SIZE	PARAMETER	SPECIFIED VALUES	UOM
0.50 mm	Resistance (max)	91	Ω/Km
	Diameter (Nom)	0.492	mm
	Elongation (Min)	20	%
	Tin Coating (Min)	1	Microns
	Persulphate Test	Should Pass	
WIRE SIZE	PARAMETER	SPECIFIED VALUES	UOM
0.40 mm	Resistance (max)	142	Ω/Km
	Diameter (Nom)	0.392	mm
	Elongation (Min)	18	%
	Tin Coating (Min)	1	Microns
	Persulphate Test	Should Pass	

Above Sizes Shall be packed in Returnable 630 mm MS Reels.

Persulphate Test : Shall be done as per IS 10810 Part 4 : 1994

We can make as per customer specifications

Note: Tinned copper wire of other specific wire sizes also available on request.

Advantages of Electro-tinned Wire Over Hot Dip Tinned Wire

- Uniform & Controlled Tin coating
- Better tin bonding with base metal i.e. copper
- Uniform wire elongation
- Re-drawable to finer sizes offering flexibility to customer



Powering the world



Power Cables

L.T. AERIAL BUNCHED CABLE



Applications:

Aerial Bunched Cables are suitable for the following fuctions:

- In power theft prone areas.
- As replacement of bare lines in rural areas, in woods, other localities & narrow street where space is limited.
- As replacement of bare lines where reliability of supply is of prime importance and where high degree of stability of supply voltage is of importance.
- In hilly terrains where cost of erection of overhead lines of under ground cable becomes very high.
- Where space is limited like those in densely populated area, dense forests.
- As reinforcement of existing system without increasing voltage.
- For temporary supplies.

Cable Construction Details

Conductor The phase conductor and neutral/street lighting conductors is of H2 or H4 grade aluminium complying with the requirements of IS 8130:1984 and conforms to flexibility class 2 of IS 8130:1984. The size of the street lighting conductor is 16 mm².

Messenger (Neutral Conductor or Otherwise) The conductor is heat treated aluminium-magnesium-silicon alloy wire conforming to IS 398 (Part 4):1979. It is either stranded circular or compacted circular type and has minimum 7 strands with smooth surface.

Insulation The conductor is insulated with crosslinked polyethylene applied by extrusion. The insulation so applied fits closely on the conductor and it is possible to remove without damaging the conductor. The color of insulation is black, offering UV protection.

Core Identification The phase conductors is provided with one, two or three 'ridges' and outer neutral insulated conductor, if provided, has four 'ridges' for quick identification. The street lighting conductor and messenger conductor (if insulated) does not have any identification mark.

Assembly (Laying up) The required number of insulated phase conductors, one insulated neutral conductor (if required) and a street lighting conductor (if required) is twisted around the bare (or insulated) as required messenger conductor without fillers with a lay not exceeding 35 times the diameter of the insulated phase conductor. The direction of lay is right hand.

Typical Cross section for Armoured Cable

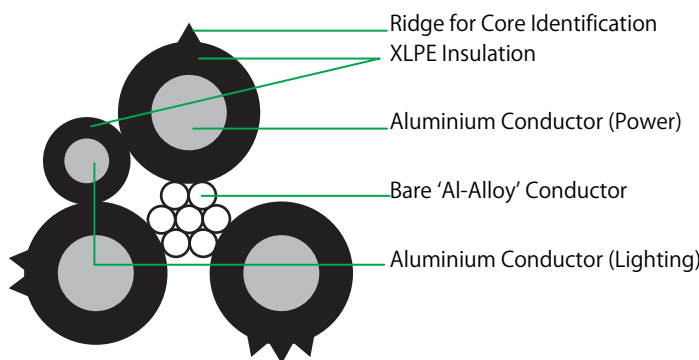



Outdoor



Aerial



RoHS compliant



Technical Particulars (as Per Is: 14255 - 1995)

Phase Conductor (Aluminium) As per IS 8130 : 1984			Street Lighting Conductor (Aluminium) As per IS 8130 : 1984			Messenger Conductor Aluminium Alloy As per IS 398 (Part-4) : 1979		
Nom. Area	Max. D.C. Conductor Resistance at 20°C	Nom. Thickness of Insulation XLPE/PE	Nom. Area	Max. D.C. Conductor Resistance at 20°C	Nom. Thickness of Insulation XLPE/P	Nom. Area	Max. D.C. Conductor Resistance at 20°C	Min. Breaking Load
Sqmm	Ω/Km	mm	Sqmm	Ω/Km	mm	Sqmm	Ω/Km	KN
16	1.910	1.2	16	1.91	1.2	25	1.380	7.0
25	1.200	1.2	16	1.91	1.2	25	1.380	7.0
35	0.868	1.2	16	1.91	1.2	25	1.380	7.0
50	0.641	1.5	16	1.91	1.2	35	0.986	9.8
70	0.443	1.5	16	1.91	1.2	50	0.689	14.0
95	0.320	1.5	16	1.91	1.2	70	0.492	19.7
120	0.253	1.5	16	1.91	1.2	95	0.357	26.5

Composition & Designation Of L.t. Aerial Bunched Cables

Designation	Complete Bunched Cable	
	Approx. Overall Dia mm	Approx. Total Mass Kg/Km
3C x 16 mm ² + 25 mm ² + 16 mm ²	20	320
3C x 25 mm ² + 25 mm ² + 16 mm ²	23	410
3C x 35 mm ² + 25 mm ² + 16 mm ²	25	500
3C x 50 mm ² + 35 mm ² + 16 mm ²	30	690
3C x 70 mm ² + 50 mm ² + 16 mm ²	34	915
3C x 95 mm ² + 70 mm ² + 16 mm ²	39	1195
3C x 120 mm ² + 70 mm ² + 16 mm ²	44	1485

Notes

We can manufacture Aerial Bunched cable as per customer's requirement meeting the National/ International specifications.

Advantages

Aerial Bunched Cables Lines have very high reliability in maintaining services because conductors are insulated with the best dielectric. The benefits of using this line are:

- Safest system because phase conductors are insulated, no risk of danger of accidental touching live conductor.
- Less fault rage on account of good protection against line and ground fault by high winds or falling trees or bird especially in hilly areas & forests as encountered in rural distribution networks.
- High insulation resistance to earth in all seasons and polluted atmospheres. Negligible leakage currents and low losses.
- Multiple circuits of power and telephone cables could be strung in the same set of poles or any other supports like walls etc.
- Better adaptability to run concurrently with existing over-head bare conductor system without any interference.
- High capacitance and low inductance leading to low impedance of lines.
- Total lines costs are reduced and maintenance is very easy.
- Insulation of conductors also helps in preventing corrosion of the conductor.
- Cores being insulated, the chances of power thefts are eliminated.
- These are cheaper than underground power cables.
- Life of Transformers increased as the supply interruptions are minimized.

INSTRUMENTATION CABLE

Generally to BS:5308 Part-1 (Polyethylene Insulation)



Typical Cross section for Armoured Cable

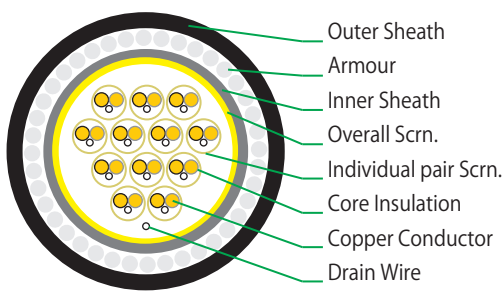

Cable Construction Details

- Operating Voltage:** 300/500V
- Size:** Available in following no of pairs : 1, 2 (1 Quad), 5, 10, 15, 20, 30 and 50 Pairs
- Conductor:** Solid/Stranded/Flexible Annealed Bare/Tinned copper class 1/2/5 to BS:6360
- Insulation & Pairing/Quading:** Conductors are insulated with solid Polyethylene Type 03 as per BS:6234, uniformly twisted together to form a pair / quad with a max. lay length of 100 mm, and colour coded for identification.
- Colour Code:** As per BS:5308 Part-1
- Pairshield:** Each twisted pair shielded with aluminium backed polyester tape and a tinned copper drain wire of size 0.5mm². (for individual pair Shielded cables only)
- Assembly:** Twister pairs are cabled with non-hygroscopic fillers if necessary
- Overall shield:** The entire assembly is shielded with aluminium polyester tape and a tinned copper drain wire of size 0.5mm².
- Bedding:** Extruded Black Polyethylene Type 2 C or 03 as per BS:6234. (applicable for Type 2 Cables)
- Wire Armouring:** A serving of round galvanized steel wires (applicable for Type 2 Cables) as per BS:1442 is applied.
- Sheath:** Type - 1 & 2 Extruded Black PVC Type TM1 of BS:6746.

Resistance, as per BS 6360

Cross Sectional Area	Maximum Resistance at 20°C/Km					
	Class - 1 Solid Copper Conductor		Class - 2 Stranded Copper Conductor		Class - 5 Flexible Copper Conductor	
	Plain	Tinned	Plain	Tinned	Plain	Tinned
0.50	36.0	36.7	36.0	36.7	39.0	40.1
0.75	24.5	24.8	24.5	24.8	26.0	26.7
1.00	18.1	18.2	18.1	18.2	19.5	20.0
1.50	12.1	12.2	12.1	12.2	13.3	13.7

Max. Mutual Capacitance

Cross Sectional Area	Requirement as per BS:5308 Part - 1		
	Cable without screen	Cables with only collective screen (except 1 & 2 pair)	1 Pair & 2 Pair with collective screen & all cables with individual pair screen
Sqmm	(nF/Km)	(nF/Km)	(nF/Km)
0.5	75	75	115
1.0	75	75	115
1.5	85	85	120

L/R ratio (Max):

- 1.5 Sqmm - 40 Micro Henry/Ω
- 0.5/0.75/1.0 Sqmm - 25 Micro Henry/Ω

Note :

1. Type 1 – Unarmoured,
2. Type 2 – Armoured
3. Other conductor Sizes and Types, Alternative Colour Codes, Higher Pair Count and Sheath Material – FR/FRLS/Zero Halogen compounds are available on request.
4. As an alternate, armoured cables shall be supplied with Flat Strip/ Double Steel Tape/ Wire Braided as per customer requirement.

INSTRUMENTATION CABLE

Generally to BS:5308 Part-2 (PVC Insulation)

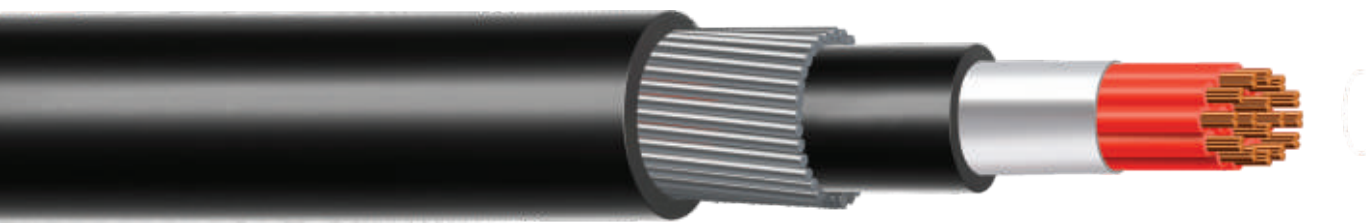

Typical Cross section for Armoured Cable

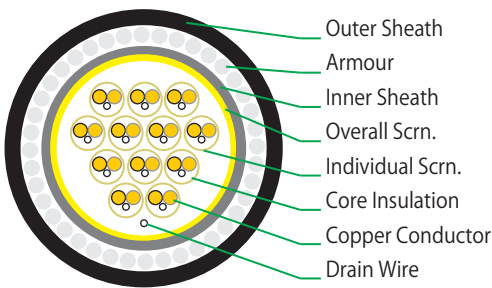

Cable Construction Details

- Operating Voltage:** 300/500V
- Size:** Available in following no of pairs : 1, 2 (1 Quad), 5, 10, 15, 20, 30 and 50 Pairs
- Conductor:** Solid/Stranded/Flexible Annealed Bare/Tinned copper class 1/2/5 to BS:6360
- Insulation & Pairing/Quading:** Conductors are insulated with solid Polyethylene Type 03 as per BS:6234, uniformly twisted together to form a pair / quad with a max. lay length of 100 mm, and colour coded for identification.
- Colour Code:** As per BS:5308 Part-1
- Pairshield:** Each twisted pair shielded with aluminium backed polyester tape and a tinned copper drain wire of size 0.5mm². (for individual pair Shielded cables only)
- Assembly:** Twister pairs are cabled with non-hygroscopic fillers if necessary
- Overall shield:** The entire assembly is shielded with aluminium polyester tape and a tinned copper drain wire of size 0.5mm².
- Bedding:** Extruded Black Polyethylene Type 2 C or 03 as per BS:6234. (applicable for Type 2 Cables)
- Wire Armouring:** A serving of round galvanized steel wires (applicable for Type 2 Cables) as per BS:1442 is applied.
- Sheath:** Type - 1 & 2 Extruded Black PVC Type TM1 of BS:6746.

Resistance, as per BS 6360

Cross Sectional Area	Maximum Resistance at 20°C/Km					
	Class - 1 Solid Copper Conductor		Class - 2 Stranded Copper Conductor		Class - 5 Flexible Copper Conductor	
	Plain	Tinned	Plain	Tinned	Plain	Tinned
0.50 Sqmm	36.0	36.7	36.0	36.7	39.0	40.1
0.75	24.5	24.8	24.5	24.8	26.0	26.7
1.00	18.1	18.2	18.1	18.2	19.5	20.0
1.50	12.1	12.2	12.1	12.2	13.3	13.7

Max. Mutual Capacitance at 1 kHz.

- Core to Core : 250 nF/Km
- Core to Screen : 450 nF/Km

L/R ratio (Max):

- 1.5 Sqmm - 40 Micro Henry/Ω
- 0.5/0.75/1.0 Sqmm - 25 Micro Henry/Ω

Note :

1. Type 1 – Unarmoured,
2. Type 2 – Armoured
3. Other conductor Sizes and Types, Alternative Colour Codes, Higher Pair Count and Sheath Material – FR/FRLS/Zero Halogen compounds are available on request.
4. As an alternate, armoured cables shall be supplied with Flat Strip/ Double Steel Tape/ Wire Braided as per customer requirement.

CONTROL CABLE

As per IS:1554 (Part-1):1988



Typical Cross section for Armoured Cable

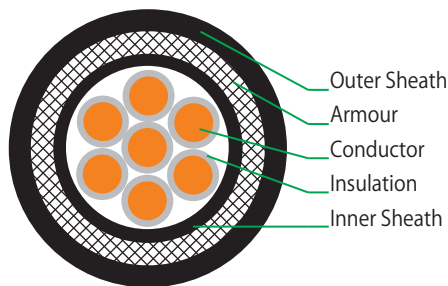

1.1 KV 1.5/2.5 Sqmm (Solid) Multicore Unarmoured PVC Control Cables
Conforming to IS: 1554 (Pt - I) - 1988

No. of Cores & Cross Sectional Area	Thickness of PVC Insulation (Nom.)	Thickness of PVC Inner Sheath (min.) Extruded	Thickness of PVC Outer Sheath (Nom.)	Approx. O.D.	Approx. Net Weight of Cable	Standard Delivery Length in	Current Rating	
							Direct in Ground	In Air/Duct
No x mm ²	mm	mm	mm	mm	Kg/Km	Mtrs	Amps.	Amps.
2 x 1.5	0.8	0.3	1.8	11.5	155	500/1000	23	20
3 x 1.5	0.8	0.3	1.8	12.0	177	500/1000	21	17
4 x 1.5	0.8	0.3	1.8	13.0	208	500/1000	21	17
5 x 1.5	0.8	0.3	1.8	14.0	243	500/1000	16	14
6 x 1.5	0.8	0.3	1.8	15.0	261	500/1000	15	13
7 x 1.5	0.8	0.3	1.8	15.0	271	500/1000	14	13
10 x 1.5	0.8	0.3	1.8	18.0	368	500/1000	13	11
12 x 1.5	0.8	0.3	1.8	18.5	416	500/1000	12	10
14 x 1.5	0.8	0.3	1.8	19.0	466	500/1000	11	10
16 x 1.5	0.8	0.3	1.8	20.0	521	500/1000	11	9
19 x 1.5	0.8	0.3	2.0	21.5	607	500/1000	10	9
24 x 1.5	0.8	0.3	2.0	24.5	749	500/1000	9	8
27 x 1.5	0.8	0.3	2.0	25.0	817	500/1000	9	8
30 x 1.5	0.8	0.3	2.0	26.0	890	500/1000	9	7
37 x 1.5	0.8	0.3	2.0	28.0	1058	500/1000	8	7
2 x 2.5	0.9	0.3	1.8	13.0	200	500/1000	32	27
3 x 2.5	0.9	0.3	1.8	13.5	234	500/1000	27	24
4 x 2.5	0.9	0.3	1.8	14.5	281	500/1000	27	24
5 x 2.5	0.9	0.3	1.8	15.5	331	500/1000	23	19
6 x 2.5	0.9	0.3	1.8	16.5	356	500/1000	21	18
7 x 2.5	0.9	0.3	1.8	16.5	374	500/1000	20	17
8 x 2.5	0.9	0.3	1.8	18.0	434	500/1000	19	16
9 x 2.5	0.9	0.3	1.8	19.0	492	500/1000	18	15
10 x 2.5	0.9	0.3	1.8	20.5	512	500/1000	18	15
12 x 2.5	0.9	0.3	2.0	21.5	602	500/1000	17	14
14 x 2.5	0.9	0.3	2.0	22.5	680	500/1000	16	14
16 x 2.5	0.9	0.3	2.0	23.5	764	500/1000	15	13
19 x 2.5	0.9	0.3	2.0	24.5	870	500/1000	14	12
24 x 2.5	0.9	0.3	2.0	28.5	1077	500/1000	13	11
27 x 2.5	0.9	0.3	2.0	29.0	1182	500/1000	12	10
30 x 2.5	0.9	0.3	2.0	30.0	1292	500/1000	12	10
37 x 2.5	0.9	0.4	2.2	32.5	1588	500/1000	11	9

Cable Construction Details

- Voltage:** These cables can be used on AC voltage up to & Including 1100 V or DC up to & including 1500 V.
- Size:** 1.5 Sq.mm. & 2.5 Sq.mm. upto 37 Cores
- Conductor:** Annealed Bare Electrolytic Copper/ Aluminum Conductor conforming to IS:8130:1984.
- Insulation:** Conductors are insulated with PVC Compound as per IS:5831:1984.
- Colour of Cores:** Cores are identified with a colour scheme as per IS:1554 (pt-1):1988 as under
 - 2 Cores - Red & Black
 - 3 Cores - Red, Yellow & Blue
 - 3½ & 4 Cores - Red, Yellow, Blue & Black (Reduced Neutral Core in case of 3½ Core).
 - 5 Cores - Red, Yellow, Blue, Black and Grey

In case of cable exceeding five cores, two adjacent (counting and direction cores) in each layer shall be colored Blue, Yellow and remaining cores grey, or identification by numbers printed over insulation as per IS:1554 (pt-1):1988

- Laying of Cores:** Cores are laid up with a suitable lay. The final layer direction shall be kept right hand lay.
- Inner Sheath:** The Inner Sheath is applied over laid up of cores by extrusion/wrapping of thermoplastic material.
- Armouring:** It is applied over inner sheath. It may consist of galvanized Round Steel wires or galvanized Flat Steel Strips conforming to IS 3975. Round Wire armouring is provided, where the calculated diameter under armour is 13.0 mm. Above this, armouring is either round wire/steel strip.
- Outer Sheath:** A final covering of PVC Compound, conforming to IS:5831:1984, is applied over Armouring in case of Armoured Cable or over Inner Sheath in case of Unarmoured cable, called as "Outer Sheath".
The Insulation, Inner Sheath or Outer Sheath can be HR PVC, FRLS PVC or FRHF Compound, depending upon their application.

Construction Variants

- Solid / Stranded annealed copper conductor & Tinned / Bare
 - General Purpose / HR PVC insulation
 - Cores laid up (filled if needed)
 - FRLS / General Purpose PVC inner sheath
 - FRLS / General purpose PVC Outersheath
- Max. Conductor D.C. Resistance at 20 Deg C - Conductor Size :**
 1.5 sq.mm - 12.1 Ω / km (Bare), 12.2 Ω / km (Tinned)
 2.5 sq.mm - 7.41 Ω / km (Bare), 7.56 Ω / km (Tinned)



1.1 KV 1.5/2.5 Sqmm (Solid) Multicore Armoured PVC Control Cables
Conforming to IS : 1554 (Pt - I) - 1988



No. of Cores & Cross Sectional Area	Thickness of PVC Insulation (Nom.)	Thickness of PVC Inner Sheath (min.) Extruded	Round Wire Dia	Flat Strip	Thickness of PVC Outer Sheath (Min.)	Approx. O.D.	Approx. Net Weight of Cable	Standard Delivery Length in	Current Rating	
									Direct in Ground	In Air/ Duct
No x mm ²	mm	mm	mm	mm	mm	Mtrs	Kg/Km	Mtrs	Amps.	Amps.
2 x 1.5	0.8	0.3	1.4		1.24	13.5	357	500/1000	23	20
3 x 1.5	0.8	0.3	1.4		1.24	14.0	390	500/1000	21	17
4 x 1.5	0.8	0.3	1.4		1.24	14.5	446	500/1000	21	17
5 x 1.5	0.8	0.3	1.4		1.24	15.5	491	500/1000	16	14
6 x 1.5	0.8	0.3	1.4		1.24	16.5	534	500/1000	15	13
7 x 1.5	0.8	0.3	1.4		1.24	16.5	544	500/1000	14	13
10 x 1.5	0.8	0.3	1.4		1.40	20.0	726	500/1000	13	11
12 x 1.5	0.8	0.3		4.0 x 0.8	1.24	19.0	632	500/1000	12	10
14 x 1.5	0.8	0.3		4.0 x 0.8	1.40	20.0	724	500/1000	11	10
16 x 1.5	0.8	0.3		4.0 x 0.8	1.40	21.0	778	500/1000	11	9
19 x 1.5	0.8	0.3		4.0 x 0.8	1.40	22.0	871	500/1000	10	9
24 x 1.5	0.8	0.3		4.0 x 0.8	1.40	25.0	1060	500/1000	9	9
27 x 1.5	0.8	0.3		4.0 x 0.8	1.40	25.5	1127	500/1000	9	8
30 x 1.5	0.8	0.3		4.0 x 0.8	1.40	26.5	1225	500/1000	9	7
37 x 1.5	0.8	0.3		4.0 x 0.8	1.40	28.0	1416	500/1000	8	7
2 x 2.5	0.9	0.3	1.4		1.24	14.5	438	500/1000	32	27
3 x 2.5	0.9	0.3	1.4		1.24	15.0	483	500/1000	27	24
4 x 2.5	0.9	0.3	1.4		1.24	16.0	554	500/1000	27	24
5 x 2.5	0.9	0.3	1.4		1.24	17.5	628	500/1000	23	19
6 x 2.5	0.9	0.3	1.4		1.24	18.5	676	500/1000	21	18
7 x 2.5	0.9	0.3	1.4		1.24	18.5	694	500/1000	20	17
8 x 2.5	0.9	0.3	1.4		1.40	20.0	793	500/1000	19	16
9 x 2.5	0.9	0.3		4.0 x 0.8	1.40	20.0	750	500/1000	18	15
10 x 2.5	0.9	0.3		4.0 x 0.8	1.40	21.0	795	500/1000	18	15
12 x 2.5	0.9	0.3		4.0 x 0.8	1.40	22.0	866	500/1000	17	14
14 x 2.5	0.9	0.3		4.0 x 0.8	1.40	23.0	969	500/1000	16	14
16 x 2.5	0.9	0.3		4.0 x 0.8	1.40	24.0	1051	500/1000	15	13
19 x 2.5	0.9	0.3		4.0 x 0.8	1.40	25.0	1181	500/1000	14	12
24 x 2.5	0.9	0.3		4.0 x 0.8	1.40	29.0	1459	500/1000	13	11
27 x 2.5	0.9	0.3		4.0 x 0.8	1.40	29.5	1564	500/1000	12	10
30 x 2.5	0.9	0.3		4.0 x 0.8	1.56	30.5	1723	500/1000	12	10
37 x 2.5	0.9	0.4		4.0 x 0.8	1.56	33.0	2014	500/1000	11	9

Construction Variants

1. Solid / Stranded annealed copper conductor & Tinned / Bare
2. General Purpose / HR PVC insulation
3. Cores laid up (filled if needed)
4. FRLS / General Purpose PVC inner sheath
5. Armouring round Galvanised Steel wires / strips
6. FRLS / General purpose PVC Outersheath

Max. Conductor D.C. Resistance at 20 Deg C - Conductor Size :

- 1.5 sq.mm - 12.1 Ω / km (Bare), 12.2 Ω / km (Tinned)
- 2.5 sq.mm - 7.41 Ω / km (Bare), 7.56 Ω / km (Tinned)

PVC INSULATED INDUSTRIAL CABLE (UNSHEATHED)

These are Single cables/cords with rigid as well as flexible annealed bare/tinned copper and aluminium conductors, insulated with PVC.



Indoor



Flame Resistant



RoHS compliant

Applications

These wires are rated for voltages upto and including 450/750 V AC, 50Hz and used for electric power and lighting including cables for outdoor and low temperature use. These cables may be used on DC system for rated voltages upto and including 1500 V to earth.



Typical Cross section

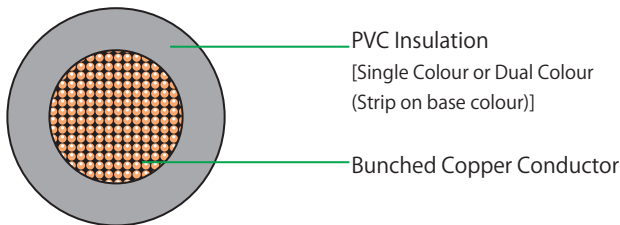

Technical Details

Nominal Cross Section Sq mm	Diameter of Single Wire Max mm	Maximum Electrical Resistance @ 20°C (Ω/Km)		Insulation Wall Thickness Nominal. mm	Cable Outer Diameter	
		Plain Wires	Tinned Wires		Nominal	Maximum
0.50	0.21	39.0	40.1	0.60	2.3	2.6
0.75	0.21	26.0	26.7	0.60	2.5	2.8
1.0	0.21	19.5	20.0	0.60	2.7	3.0
1.5	0.26	13.30	13.70	0.70	3.1	3.4
2.5	0.26	7.98	8.21	0.80	3.8	4.1
4.0	0.31	4.95	5.09	0.80	4.3	4.8
6.0	0.31	3.30	3.39	0.80	4.9	5.3
10.0	0.41	1.91	1.95	1.00	6.2	7.0
16.0	0.41	1.21	1.24	1.00	7.3	8.1
25.0	0.41	0.41	0.780	1.20	9.0	10.2
35.0	0.41	0.554	0.565	1.20	10.2	11.7
50.0	0.41	0.386	0.393	1.40	12.2	13.9

Features:

- Categories of Cables: Indoor, Outdoor, FR and FR-LSH.
- Temperature Range: -10° C to +70° C or +85° C.
- Available in different colors and stripes.
- Available in Leaded or Lead free grades.
- Packed in Coils of suitable standard lengths.
- BIS Certification vide IS 694 Licence No. CM/L 3050333

Note:

Cables upto 300 Sqmm with Flexible conductor (Class 5 of Copper Conductor as per IS 8130) can be supplied.

Cables upto 630 Sqmm with Rigid conductor (Class 1 or 2 of Copper or Aluminium Conductor as per IS 8130) can be supplied.

PVC INSULATED INDUSTRIAL CABLE (SHEATHED)

These are Single and multicore cables/cords with rigid as well as flexible annealed bare/tinned copper and aluminium conductors, insulated and sheathed with PVC.



Indoor



Flame Resistant



RoHS compliant

Applications

These wires are rated for voltages upto and including 450/750 V AC, 50Hz and used for electric power and lighting including cables for outdoor and low temperature use. These cables may be used on DC system for rated voltages upto and including 1500 V to earth.



Typical Cross section

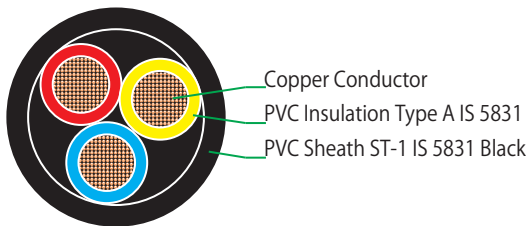

Technical Details

Nominal Cross Section Sq mm	Diameter of Single Wire Max mm	Maximum Electrical Resistance @ 20°C (Ω/Km)		Insulation Wall Thickness Nominal mm.	Sheath Thickness Nominal mm.	Cable Outer Diameter	
		Plain Wires	Tinned Wires			Nominal	Maximum
0.50	0.21	39.0	40.1	0.60	0.90	7.0	7.3
0.75	0.21	26.0	26.7	0.60	0.90	7.4	7.7
1.0	0.21	19.50	20.0	0.60	0.90	7.8	8.1
1.5	0.26	13.30	13.70	0.60	0.90	8.3	9.4
2.5	0.26	7.98	8.21	0.70	1.00	9.9	10.9
4.0	0.31	4.95	5.09	0.80	1.00	11.5	12.4
6.0	0.31	3.30	3.39	0.80	1.20	13.1	13.8
10.0	0.41	1.91	1.95	1.00	1.40	16.5	17.69
16.0	0.41	1.21	1.24	1.00	1.40	18.8	20.6
25.0	0.41	0.780	0.795	1.20	1.50	22.6	25.6
35.0	0.41	0.554	0.565	1.20	1.60	25.3	29.3
50.0	0.41	0.386	0.393	1.40	2.00	30.2	34.6

Note:

- a) Multicore Cables upto 120 Sqmm with Rigid conductor (Class 1 or 2 of Copper or Aluminium Conductor as per IS 8130) can be supplied
- b) Multicore Cables upto 300 Sqmm with Flexible conductor (Class 5 Copper Conductor as per IS 8130) can be supplied.



Typical Cross section

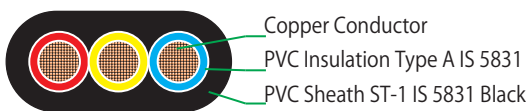

Technical Details

Nominal Cross Section Sq mm	Diameter of Single Wire Max mm	Maximum Electrical Resistance @ 20°C (Ω/Km)		Insulation Wall Thickness Min. mm	Sheath Thickness Nominal	Cable Outer Diameter mm
		Plain Wires	Tinned Wires			
0.50	0.21	39.0	40.1	0.60	0.90	9.6x4.9
0.75	0.21	26.0	26.7	0.60	0.90	10.5x5.2
1.0	0.21	19.5	20.0	0.60	0.90	11.0x5.4
1.5	0.26	13.30	13.70	0.70	0.90	10.7x5.3
2.5	0.26	7.98	8.21	0.80	1.00	13.0x6.2

Features:

- Categories of Cables: Indoor, Outdoor, FR and FR-LSH.
- Temperature Range: -10° C to +70° C or +85° C.
- Available in different colors and stripes.
- Available in Leaded or Lead free grades.
- Packed in Coils of suitable standard lengths.
- BIS Certification vide IS 694 Licence No. CM/L 3050333

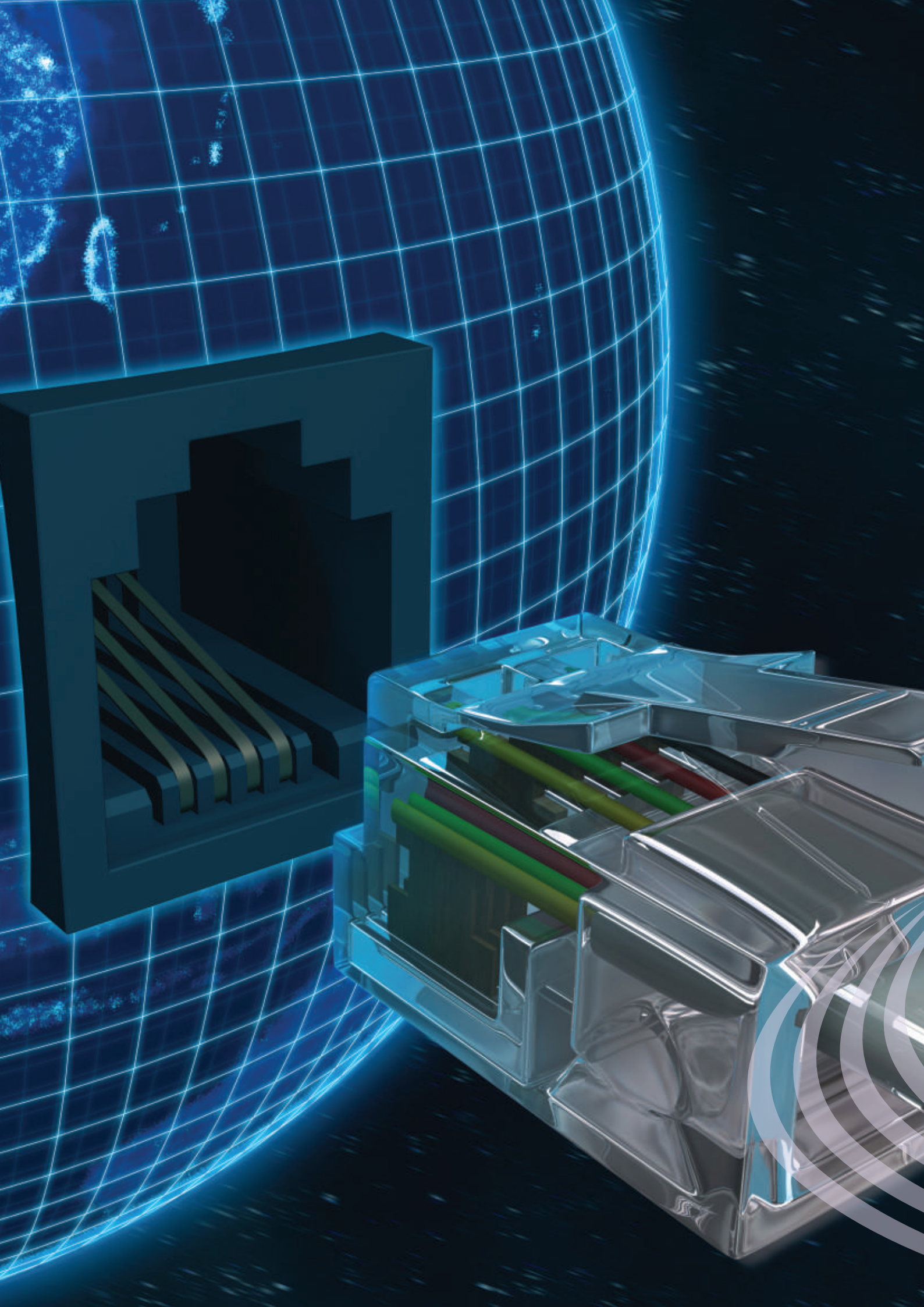

*Communication.....
made simple
in a special way*

Structured Cables

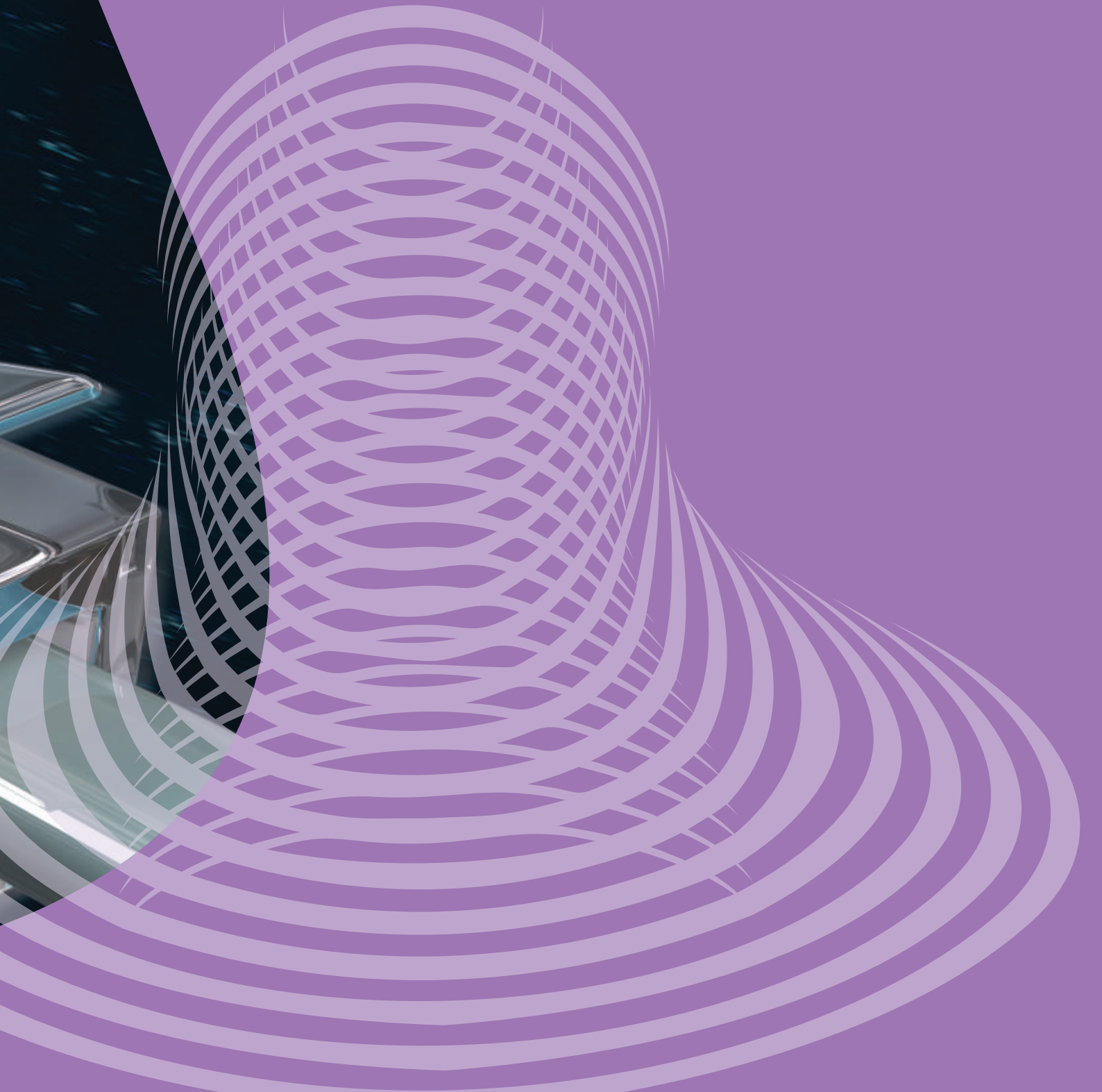

4PAIR CAT 7 23AWG F/FTP CABLE



Indoor



Flame Resistant



RoHS compliant

Applications

These cable Support Ethernet applications requiring Class D to F (10GBase-T, 1000Base-T, 100Base-TX, ATM) as well as VoIP, PoE Performance Specified up to 600Mhz.



Typical Cross section

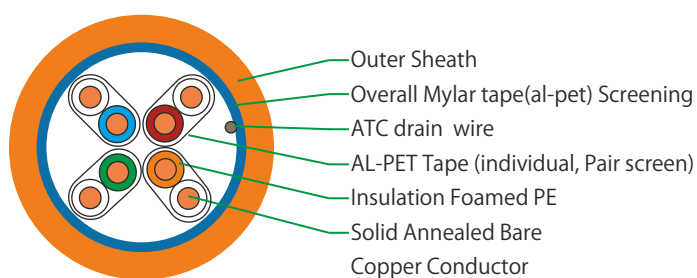

- Outer Sheath
- Overall Mylar tape(al-pet) Screening
- ATC drain wire
- AL-PET Tape (individual, Pair screen)
- Insulation Foamed PE
- Solid Annealed Bare Copper Conductor

Description:

Conductor	: 23AWG Solid Annealed Bare Copper Conductor
Insulation	: Foam Polyethylene, nominal diameter 1.4mm
Pair	: Each pair wrapped with Aluminium/Polyester (Mylar) Tape
Laid Up	: Four Individually Screened pairs stranded into cable core
Drain wire	: ATC nominal diameter 26AWG
Outer Sheath Colour:	Grey or per request
Outer Sheathing	: LSZH or PVC as per request
Cable Diameter	: 7.5 ± 0.50 mm

Features:

- ISO/IEC-11801, Class F / IEC 61156-5: Category 7
- LSZH Properties: IEC 60332-1, IEC 61034 ,IEC 60754-1&2
- Packaged in wooden Spool.
- Cable Characterized up to 600 MHz,
- Individually Screened pairs.
- Overall Mylar screen
- ATC drain wire

Colour Code:

Pair 1	: White -Blue
Pair 2	: White -Orange
Pair 3	: White -Green
Pair 4	: White -Brown

Standard Length & Packing:

Packing Length	: 305m
Spool Dimension(FxBxT)	: 14x 6x12 Inch

Electrical Characteristics:

Conductor Resistance @20 deg.	Max. 14.5 Ω/100m
Conductor Resistance Unbalance	Max. 5 %
Capacitance Earth Unbalance	Max. 1600 pF/Km
Insulation Resistance@500VDC	Min. 5000 M Ohm. km
Dielectric Strength	DC 1.5kv/2s
VOP	Nom 70%
Propagation Delay Skew	Max. 45 ns/100 m
Characteristics Impedance	100 Ω, ± 25 Ω

Technical Details

Freq (MHZ)	Attenuation (dB/100m)	NEXT (dB)	PSNEXT (dB)	ACRF (ELFEXT) (dB)	PSACRF (PSELFEXT) (dB)	Return Loss (dB)
Max.	Min.	Min.	Min.	Min.	Min.	
1	4	65	62	65	62	19
16	8.1	65	62	57.5	54.5	18
100	20.8	62.9	59.9	44.4	41.4	12
250	33.8	56.9	53.9	37.8	34.8	8
500	49.3	52.4	49.4	32.6	29.6	8
600	54.6	51.2	48.2	31.3	28.3	8

Note: Supplied cable shall be passed 70m Fluke Channel Test.

Mechanical Properties:

Bending radius	: 8 x overall diameter (min.)
Pulling Force	: Max 130 N

Thermal Characteristics:

Operating Temperature	: -10°C to +60°C
Installation Temperature	: -0°C to +50°C

4 PAIR CAT 7 - 23AWG S/FTP CABLE



Indoor



Flame Resistant



RoHS compliant

Applications

These cable Support Ethernet applications requiring Class D to F (10GBase-T, 1000Base-T, 100Base-TX, ATM) as well as VoIP, PoE. Performance specified up to 600Mhz.



Typical Cross section

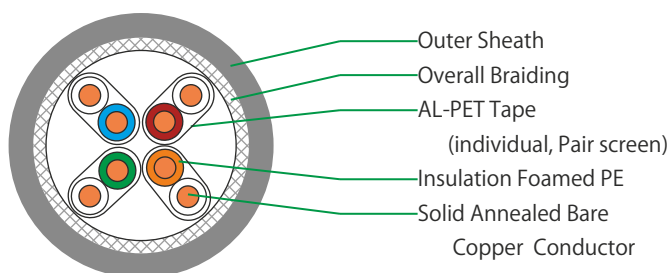

Description:

Conductor	: 23AWG Solid Annealed Bare Copper Conductor
Insulation	: Foam Polyethylene, diameter- 1.4 mm (nom)
Pair Screening	: Each pair wrapped with Aluminium/Polyester (Mylar) Tape
Laid Up	: Four Individually Screened pairs stranded into cable core
Overall Screening	: AL-Alloy /ATC braiding, Coverage \geq 30 %
Outer Sheathing	: LSZH or PVC, Colour: Grey or per request
Cable Diameter	: 8.0 ± 0.50 mm

Features:

- ISO/IEC-11801, Class F / IEC 61156-5: Category 7
- LSZH Properties: IEC 60332-1, IEC 61034 ,IEC 60754-1&2
- Packaged in wooden Spool.
- Cable Characterized up to 600 MHz,
- Individually Screened pairs.
- Overall ATC Braiding screen

Colour Code:

Pair 1	: White -Blue
Pair 2	: White -Orange
Pair 3	: White -Green
Pair 4	: White -Brown

Standard Length & Packing:

Packing Length	: 305m
Spool Dimension(FxBxT)	: 14x 06x12 Inch

Electrical Characteristics:

Conductor Resistance @20 deg.	Max. 14.5 Ω /100m
Conductor Resistance Unbalance	Max. 2 %
Capacitance Earth Unbalance	Max. 1600 pF/Km
Dielectric Strength	DC 1.5 KV/2s
Propagation Delay Skew	Max. 25 ns/100 m

Technical Details

Freq (MHZ)	Attenuation (dB/100m)	NEXT (dB)	PSNEXT (dB)	ACRF (ELFEXT) (dB)	PSACRF [PSELFEXT] (dB)	Return Loss (dB)
Max.	Min.	Min.	Min.	Min.	Min.	
1	4	65	62	65	62	19
16	8.1	65	62	57.5	54.5	18
100	20.8	62.9	59.9	44.4	41.4	12
250	33.8	56.9	53.9	37.8	34.8	8
500	49.3	52.4	49.4	32.6	29.6	8
600	54.6	51.2	48.2	31.3	28.3	8

Note: Supplied cable shall be passed 70m Fluke Channel Test.

Mechanical Properties:

Bending radius	: 8 x overall diameter (min.)
Pulling Force	: Max 130 N

Thermal Characteristics:

Operating Temperature	: -10°C to +60°C
Installation Temperature	: -0°C to +50°C

4PAIR CAT6 23AWG SFTP ARMoured CABLE



Indoor



Flame Resistant



RoHS compliant

Applications

Enhanced performance cable for transmission of high-speed data, digital and analogue voice and video (RGB) signals on LANs. Supports Gigabit Ethernet (1000 base) standard.

This cable meets the requirements of TIA Cat6 Channel Spec (70M)



Typical Cross section

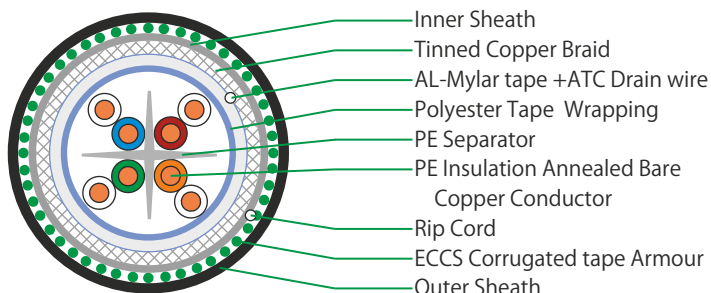

Description:

Conductor	: 23 AWG Solid Annealed Bare Copper Conductors.
Insulation	: HDPE, Diameter-1.08+/-0.05mm
Twisting	: 4 pairs laid up over polyethylene cross separator
Wrapping	: Overall Polyester Tape,
HF-Screening	: AL-PET Tape (Mylar)
Braiding	: Tinned copper conductor,
Rip cord	: Rip cord, applied under the jacket
Inner Sheath	: LSZH/ PVC Compound, as per request
Colour	: Black or Grey, per request
Armour	: ECCS corrugated tape Armour
Outer Sheath	: LSZH/PVC/PE as per request
Cable Diameter	: 12.0 +/- 1.5mm

Features:

- ANSI/TIA- 568- C.2-2009 and ISO/ IEC 11801 – 2nd Edition.
- Cable Tested upto 650Mhz
- Overall Mylar tape Screened core.
- ATC overall braid with Drain wire.
- ECCS tape Armour provides Excellent Mechanical protection
- Flame Properties ; IEC 60332-1, IEC 60754-1&2 and IEC 61034

Colour Code:

- Pair 1 : Blue + White -Blue
- Pair 2 : Green+White -Orange
- Pair 3 : Green+White -Green
- Pair 4 : Brown+White -Brown

Cable Diameter, Standard Length & Packing:

305m Spools Dimension(FxBxT) : 24 x 14 x 14 Inch

Electrical Characteristics:

Conductor Resistance @20°C	Max. 93.8 Ω/Km
Conductor Resistance Unbalance	Max. 5 %
Mutual Capacitance @1KHZ	Max. 56 nF/Km
Insulation Resistance	Min. 5000 MΩ.km
High voltage	2.5 Kv DC/2s
Capacitance Earth Unbalance	Max. 3300 pF/km
Propagation Delay Skew	Max. 50 ns/100 m
Characteristic Impedance	100 ± 15Ω

Technical Details

Freq (MHZ)	Attenuation (dB/100m)	NEXT (dB)	PSNEXT (dB)	ACRF (ELFEXT) (dB)	PSACRF [PSELFEXT] (dB)	Return Loss (dB)
Max.	Min.	Min.	Min.	Min.	Min.	
1	2.1	65.0	62.0	63.3	60.3	19
4	4.0	63.0	60.5	51.2	48.2	19
8	5.7	58.2	55.6	45.2	42.2	19
10	6.3	56.6	54.0	43.3	40.3	19
16	8.0	53.2	50.6	39.2	36.2	18
20	9.0	51.6	49.0	37.2	34.2	17
25	10.1	50.0	47.3	35.3	32.3	17
31.25	11.4	48.4	45.7	33.4	30.4	17
62.5	16.5	43.4	40.6	27.3	24.3	14
100	21.3	39.9	37.1	23.3	20.3	12
200	31.5	34.8	31.9	17.2	14.2	9
250	36.0	33.1	30.2	15.3	12.3	8
300	40.1	31.7	28.8	13.7	10.7	7
400	47.8	29.6	26.6	11.2	8.2	6
500	55.1	27.9	24.8	9.3	6.3	5
600	61.95	26.5	23.4	7.7	4.7	4
650	65.31	25.9	22.8	7.0	4.0	4

Note: Supplied cable guaranteed to pass 70m Fluke Channel Test as per ANSI/TIA 568-C.2.

Mechanical Properties:

Bending radius	: 20 x Diameter (min.)
Pulling Force	: 11.5 kgs (max.)

Thermal Characteristics:

Operating Temperature : - 20°C to +60°C

4 PAIR CAT6 24 AWG UTP CABLE



Indoor



Flame Resistant



RoHS compliant

Applications

Horizontal cabling networks for transmission of high speed data, digital and analog, voice and video signals over LANs. Supports gigabit Ethernet (1000 Base-T) standard suitable for noisy environments, high EMI interference surroundings and complies to the requirement of ANSI/TIA-568-C.2 and ISO/IEC 11801.



Typical Cross section

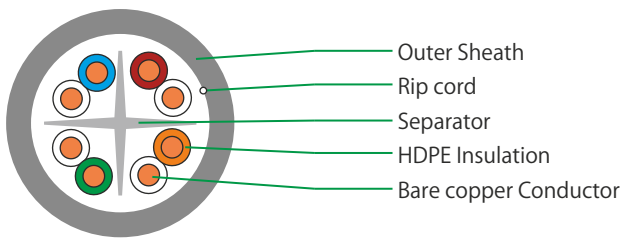

Description:

Conductor	: 24AWG Solid bare copper conductor
Insulation/td>	: High Density Polyethylene.
Insulation diameter	: 0.95 ± 0.03mm
Pair	: Two Insulated conductors Twisted together to form pair,
Cabling	: All pairs are assembled making the core cable. It shall be used a central element (filler /slot) made of a thermoplastic material to separate all 4 pairs.
Jacket	: PVC/LSZH, Compound
Colour	: Grey or as per request
Rip Cord	: Longitudinally applied below the Jacket.
Cable Diameter	: 5.8 ± 0.30 mm

Features:

- Generally Complied ANSI/TIA-568-C.2 (Category 6),ISO/IEC 11801 2nd ed(Class E)
- Supports all applications designed to operate over Category 6 or lower rated systems
- Performance verified upto 250MHz.
- Spool in box Packaging
- UL Listed , CM rated
- ROHS Compliant.

Colour Code:

- Pair 1 : White/Blue Strip -Blue
- Pair 2 : White/Orange Strip -Orange
- Pair 3 : White/Green Strip-Green
- Pair 4 : White/Brown Strip-Brown

Electrical Characteristics:

Conductor Resistance	Max. 9.38 Ω/100m
Conductor Resistance Unbalance	Max. 5 %
Nom Mutual Capacitance	Max. 5.6 nF/100m
Capacitance Earth Unbalance	Max. 330 pF/100m
Maximum Delay @ 100 MHZ	Max. 538 ns/100 m
Nominal Velocity of Propagation	69%(nom)
Propagation Delay Skew 1 – 250 MHZ	Max. 45 ns/100 m
Maximum Intended Operating Voltage	72 VDC
Characteristic Impedance (1-250 MHz)	100 ± 15Ω

Technical Details

Freq (MHZ)	Attenuation (dB/100m)	NEXT (dB)	PSNEXT (dB)	ACRF (ELFEXT) (dB)	PSACRF [PSELFEXT] (dB)	Return Loss (dB)
Max.	Min.	Min.	Min.	Min.	Min.	
1	2.1	65	62	63.3	60.3	19
4	4	63	60.5	51.2	48.2	19
8	5.7	58.2	55.6	45.2	42.2	19
10	6.3	56.6	54	43.3	40.3	19
16	8	53.2	50.6	39.2	36.2	18
20	9	51.6	49	37.2	34.2	17
25	10.1	50	47.3	35.3	32.3	17
31.25	11.4	48.4	45.7	33.4	30.4	17
62.5	16.5	43.4	40.6	27.3	24.3	14
100	21.3	39.9	37.1	23.3	20.3	12
200	31.5	34.8	31.9	17.2	14.2	9
250	36	33.1	30.2	15.3	12.3	8

Note: Supplied cable guaranteed to pass 90m Fluke Channel Test as per ANSI/TIA 568-C.2.

Mechanical Properties:

Bending radius	: 4 x overall diameter (min.)
Breaking Strength	: 400 N (max.)

Standard Length & Packing:

305m Plastic Reel in Carton : 13 x 10 x 14 inch

Thermal Characteristics:

Operating Temperature	: - 20°C to +70°C
-----------------------	-------------------

4PAIR CAT6 23 AWG UTP PVC CABLE



Indoor



Flame Resistant



RoHS compliant

Applications

These structure cable suitable for Gigabyte Ethernet Applications and compatible with all known connection Systems, Ideal for high performance workstation applications including voice/data systems, Digital video, Broadband and Voice over internet protocol etc.



Typical Cross section

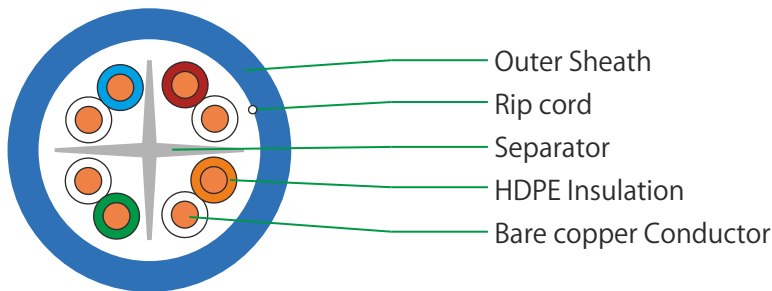

Electrical Characteristics:

Conductor Resistance@20°C	Max. 9.38 Ω/100m
Conductor Resistance Unbalance	Max. 5 %
Mutual Capacitance	Max. 5.6 nF/100m
Capacitance Earth Unbalance	Max. 330 pF/100m
Dielectric strength	2.5Kv/2s
Insulation Resistance@500VDC, 1 minute	5000 Mega ohm.km
Characteristic Impedance (1-250 MHz)	100 ± 15Ω
Nominal velocity of Propagation	69%
Propagation Delay Skew 1 – 250 MHz	Max. 45 ns/100 m

Description:

Conductor	: 23AWG Solid bare copper conductor
Insulation	: High Density Polyethylene, Diameter 0.98 ± 0.05mm)
Pairs	: Two Insulated conductors Twisted together to form pair
Twisting	: 4 pairs laid together over X-Separator
Jacket	: PVC/LSZH Compound
Colour	: Blue/Grey or per request
Cable Diameter	: 6.0 ± 0.3 mm

Features:

- Complies to the requirements of ANSI/TIA 568 C.2 and ISO/IEC 11801 – 2nd Edition ;
- Cable Characterized up to 250 MHz,
- Packing Pull out box

Colour Code:

- Pair 1 : White/Blue Strip -Blue
- Pair 2 : White/Orange Strip -Orange
- Pair 3 : White/Green Strip -Green
- Pair 4 : White/Brown Strip -Brown

Standard Length & Packing:

305m Plastic Reel in Carton : 13 x 10 x 14 inch

Technical Details

Freq (MHZ)	Attenuation (dB/100m)	NEXT (dB)	PSNEXT (dB)	ACRF (ELFEXT) (dB)	PSACRF [PSELFEXT] (dB)	Return Loss (dB)
Max.	Min.	Min.	Min.	Min.	Min.	
1	2.1	65	62	63.3	60.3	19
4	4	63	60.5	51.2	48.2	19
8	5.7	58.2	55.6	45.2	42.2	19
10	6.3	56.6	54	43.3	40.3	19
16	8	53.2	50.6	39.2	36.2	18
20	9	51.6	49	37.2	34.2	17
25	10.1	50	47.3	35.3	32.3	17
31.25	11.4	48.4	45.7	33.4	30.4	17
62.5	16.5	43.4	40.6	27.3	24.3	14
100	21.3	39.9	37.1	23.3	20.3	12
200	31.5	34.8	31.9	17.2	14.2	9
250	36	33.1	30.2	15.3	12.3	8

Note: Supplied cable shall be passed Fluke channel Test. Cable measurements are made on 100m length at 20°C . Length pulled out of their packages and released on a non-conductive surface as described in ANSI/TIA-568-C.2.

Mechanical Properties:

Bending Radius	: 4 x overall diameter (min.)
Breaking Strength	: 400 N (max.)

Thermal Characteristics:

Operating Temperature	: - 20°C to +70°C
-----------------------	-------------------

4PAIR CAT6 23AWG UTP ARMoured CABLE



Indoor



Flame Resistant



RoHS compliant

Applications

Enhanced performance cable for transmission of high-speed data, digital and analogue voice and video (RGB) signals on LANs. Supports Gigabit Ethernet (1000 baseT) standard. Operates at bandwidth of 250MHz. This cable meets the requirements of TIA Cat6 Channel Spec (50M)



Typical Cross section

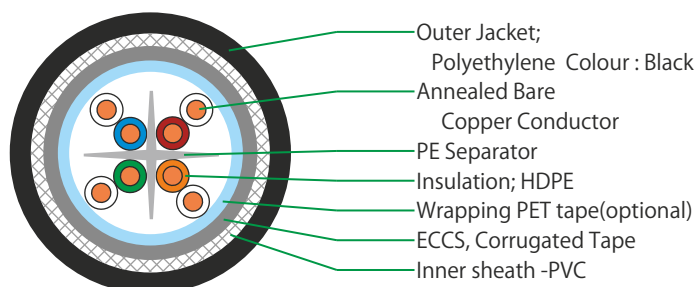

Description:

Conductor	: 23 AWG Solid Bare Copper conductor
Insulation	: High Density Polyethylene
Pairs	: Two Insulated conductors Twisted together to form pair
Twisting	: 4 pairs laid together and separated by cross element
Inner Sheath	: PVC/LSZH, compound
Armour	: ECCS, Corrugated Tape ; 0.125mm
Jacket	: HDPE, Colour: Black
Cable Diameter	: 10.5 ± 0.5 mm

Features:

- Generally complied to ANSI/TIA-568-C.2:2009 Category 6 & ISO/IEC 11801, EN 50173
- Performance specification up to 250 MHz.
- UV resistance outer sheath ,
- Inner Sheath Flame Retardant (IEC60332-1)
- Suitable for Outdoor application.
- Rugged Double sheath construction.
- RoHS Compliant.
- Steel tape (ECCS) Armour provides Excellent Mechanical protection.

Colour Code:

- Pair 1 : White/Blue Strip -Blue
- Pair 2 : White/Orange Strip -Orange
- Pair 3 : White/Green Strip-Green
- Pair 4 : White/Brown Strip -Brown

Electrical Characteristics:

Conductor Resistance @20°C	Max. 93.8 Ω/KM
Conductor Resistance Unbalance	Max. 5 %
Mutual Capacitance @1KHZ	Max. 56 nF/KM
Insulation Resistance	min. 5000 MΩ.km
High voltage	2.5 Kv DC/1 min
Capacitance Earth Unbalance	Max. 3300 pF/km
Propagation Delay @ 1, 10, 100 &250 MHz	Max. 570, 545,538 & 536ns/100 m536ns/100 m
Propagation DeLay Skew 1 – 250 MHz	Max. 45 ns/100 m

Technical Details

Freq (MHZ)	Attenuation (dB/100m)	NEXT (dB)	PSNEXT (dB)	ACRF (ELFEXT) (dB)	PSACRF [PSELFEXT] (dB)	Return Loss (dB)
Max.	Min.	Min.	Min.	Min.	Min.	
1	2.1	65	62	63.3	60.3	19
4	4	63	60.5	51.2	48.2	19
8	5.7	58.2	55.6	45.2	42.2	19
10	6.3	56.6	54	43.3	40.3	19
16	8	53.2	50.6	39.2	36.2	18
20	9	51.6	49	37.2	34.2	17
25	10.1	50	47.3	35.3	32.3	17
31.25	11.4	48.4	45.7	33.4	30.4	17
62.5	16.5	43.4	40.6	27.3	24.3	14
100	21.3	39.9	37.1	23.3	20.3	12
200	31.5	34.8	31.9	17.2	14.2	9
250	36	33.1	30.2	15.3	12.3	8

Note: Supply cable guaranteed to pass 50m Channel test as per ANSI/TIA-568-C.2 Category 6, testing configuration as one cable segment and 2 connector direct attached fluke tester

Mechanical Properties:

Min Bending radius	: 20x Diameter (mm)
Pulling Force	: 11.5Kg (max.)

Standard Length & Packing:

305m Spool Dimension (LxBxH): 20 x10x12 Inch

Thermal Characteristics:

Operating Temperature : - 20°C to +70°C

4 PAIR CAT 6A 23AWG F/UTP DOUBLE SHEATH CABLE



Indoor



Flame Resistant



RoHS compliant

Applications

These structure cable suitable for Ethernet Applications and compatible with all known connection Systems, Ideal for high performance workstation applications including voice/data systems, Digital video, Broadband and Voice over internet protocol etc.



Typical Cross section

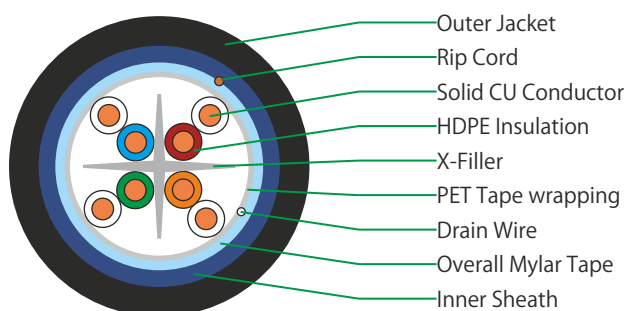

Description:

Conductor	: 23 AWG Solid Bare Copper Conductor
Insulation	: Polyethylene(HDPE), Thickness 0.28mm(nom)
Pair Screening	: Two Insulated conductors Twisted together
Laid Up	: Four pairs stranded over X-Filler into cable core
Wrapping	: Overall PET tape wrapping
Overall Screening	: AL/PET Mylar tape + Drain wire
Inner sheath	: LSZH/PVC, Colour: Black or grey
Outer Sheathing	: Polyethylene/LSZH/PVC as per request, Colour: Black or per request
Cable Diameter	: 9.2mm ± 0.5 mm

Features:

- Generally Complies to the requirements of TIA/EIA 568 C.2
- Packaged in wooden Spool.
- Cable Characterized up to 500 MHz,
- Overall Mylar tape Screening
- ATC Drain wire.
- Excellent EMC performance
- Double sheath Construction
- LSZH Properties ; IEC 60332-1, IEC 60754-1&2 and IEC 61034

Colour Code:

- Pair 1 : White/Blue Strip -Blue
- Pair 2 : White/Orange Strip -Orange
- Pair 3 : White/Green Strip-Green
- Pair 4 : White/Brown Strip -Brown

Electrical Characteristics:

Conductor Resistance @20°C	Max. 9.38 Ω/100m
Conductor Resistance Unbalance	Max. 5 %
Mutual Capacitance	Max. 5.6 nF/KM
Capacitance Earth Unbalance	Max. 330 pF/100m
Insulation Resistance@ 500v DC/1 minute	Min. 5000 MOhm km
Dielectric Strength	DC 2500V/2s
Propagation Delay @ 1 , 10 , 100 & 500 MHz	Max. 570, 545, 538 & 536 ns/100 m
Propagation Delay Skew 1 –500 MHz	Max. 50 ns/100 m

Technical Details

Freq (MHZ)	Attenuation (dB/100m)	NEXT (dB)	PSNEXT (dB)	ACRF (ELFEXT) (dB)	PSACRF [PSELFEXT] (dB)	Return Loss (dB)
Max.	Min.	Min.	Min.	Min.	Min.	
1	2.3	65	62	63.3	60.3	19
4	4.2	63	60.5	51.2	48.2	19
8	5.8	58.2	55.6	45.2	42.2	19
10	6.5	56.6	54	43.3	40.3	19
16	8.2	53.2	50.6	39.2	36.2	18
20	9.2	51.6	49	37.2	34.2	17.5
25	10.2	50	47.3	35.3	32.3	17
31.25	11.5	48.4	45.7	33.4	30.4	16.5
62.5	16.4	43.4	40.6	27.3	24.3	14
100	20.9	39.9	37.1	23.3	20.3	12
200	30.1	34.8	31.9	17.2	14.2	9
250	33.9	33.1	30.2	15.3	12.3	8
300	37.4	31.7	28.8	13.7	10.7	7.2
400	43.7	28.7	25.8	11.2	8.2	6
500	49.3	26.1	23.2	9.3	6.3	6

Note: Supplied cable 70m shall be passed Fluke Channel Test as per ANSI/TIA 568-C.2.

Mechanical Properties:

Bending radius	: 10 x Overall diameter (min.)
Pulling Force	: Max 130 N

Standard Length & Packing:

305m Spool Dimension (FxBxT)	: 22x14x14 Inch
500m Spool Dimension (FxBxT)	: 24x14x14 Inch

Thermal Characteristics:

Operating Temperature	: - 20°C to +60°C
Installation Temperature	: -0°C to +50°C

4 PAIR CAT 6A 23AWG U/ FTP LSZH CABLE



Indoor



Flame Resistant



RoHS compliant

Applications

These structure cable suitable for Ethernet Applications and compatible with all known connection Systems, Ideal for high performance workstation applications including voice/data systems, Digital video, Broadband and Voice over internet protocol etc.

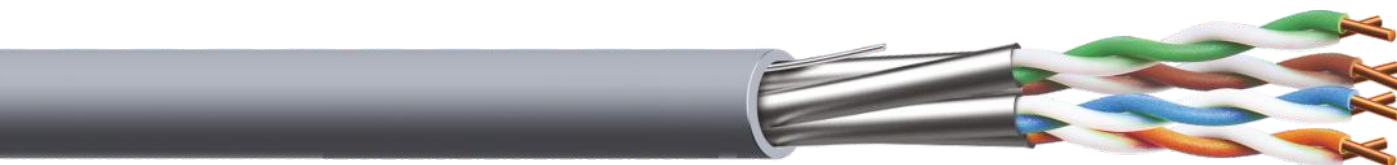

Typical Cross section

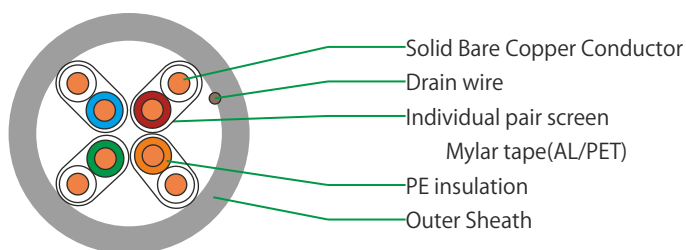

Description:

Conductor	: 23A WG Solid Annealed Bare Copper Conductor
Insulation	: Foamed Polyethylene, diameter 1.3mm(nom)
Pair Screening	: Each pair wrapped with Aluminium/Polyester(Mylar)Tape,
Laid Up	: Four Individually Screened pairs stranded into cable core.
Drain Wire	: Annealed Tinned Copper Wire
Outer Sheathing	: LSZH or PVC Compound, as per request
Cable Diameter	: 7.2 ± 0.50 mm

Features:

- Generally complied requirements of ISO 11801 Class EA , IEC 61156-5 & TIA/EIA 568 C.2
- Packaged in wooden Spool.
- Cable Characterized up to 500 MHz,
- Individually screened pair

Colour Code:

- Pair 1 : White/Blue
- Pair 2 : White/Orange
- Pair 3 : White/Green
- Pair 4 : White/Brown

Electrical Characteristics:

Conductor Resistance @20°C	Max. 9.38 Ω/100m
Conductor Resistance Unbalance	Max. 5 %
Capacitance Earth Unbalance	Max.330 pF/100m
Dielectric Strength	DC 1500V/2s
Propagation Delay Skew 1 –500 MHz	Max. 45 ns/100 m

Technical Details

Freq (MHz)	Attenuation (dB/100m)	NEXT (dB)	PSNEXT (dB)	ACRF (ELFEXT) (dB)	PSACRF [PSELFEXT] (dB)	Return Loss (dB)
Max.	Min.	Min.	Min.	Min.	Min.	
4	4.2	63	60.5	51.2	48.2	19
8	5.8	58.2	55.6	45.2	42.2	19
10	6.5	56.6	54	43.3	40.3	19
16	8.2	53.2	50.6	39.2	36.2	18
20	9.2	51.6	49	37.2	34.2	17.5
25	10.2	50	47.3	35.3	32.3	17
31.25	11.5	48.4	45.7	33.4	30.4	16.5
62.5	16.4	43.4	40.6	27.3	24.3	14
100	20.9	39.9	37.1	23.3	20.3	12
200	30.1	34.8	31.9	17.2	14.2	9
250	33.9	33.1	30.2	15.3	12.3	8
300	37.4	31.7	28.8	13.7	10.7	7.2
400	43.7	28.7	25.8	11.2	8.2	6
500	49.3	26.1	23.2	9.3	6.3	6

Note: Supply cable guaranteed to pass 70m Channel test as per ANSI/TIA-568-C.2 Category 6a

Mechanical Properties:

MBR installed(mm)	: 8 x OD
Max. Pulling force	: 100N

Standard Length & Packing:

305m Wooden Spool Dimension(FxBxT) : 14 x 6 x 12 Inch

Thermal Characteristics:

Operating Temperature	: - 10°C to +60°C
Installation Temperature	: -0°C to +50°C

4 PAIR CAT 6A 23AWG UTP CABLE



Indoor



Flame Resistant



RoHS compliant

Applications

Cat6A UTP Cable 4 Pairs is suitable for Horizontal Cabling Systems. Used to transmit High Speed Data, Voice and Video signals both digital & analog through entire CHANNEL. With 500 MHz operational bandwidth it well exceeds the requirement of ANSI/TIA 568-C.2 and ISO 11801.



Typical Cross section

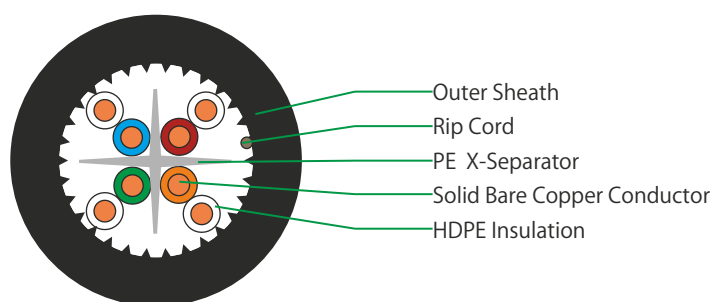

Description:

Conductor	23AWG Solid Annealed Bare Copper Conductor
Insulation	High Density Polyethylene
Pairs	Two Insulated conductors Twisted together to form pair ,lay 30mm
Twisting	4 pairs laid together and separated by cross element
Sheath	PVC/LSZH, inside corrugated Jacket
Colour	Grey or as per request.
Cable Diameter	7.2 ± 0.4 mm

Features:

- Reference standard TIA/EIA 568 C.2 (Category 6a) & ISO/IEC 11801 2nd ed(Class Ea)
- Packaged in Wooden Spool.
- True 23 AWG Solid Bare Copper
- 305 Meters Reel. 500 Meters Reel in Option
- Channel" Performance Warranty

Colour Code:

- Pair 1 : White/Blue Strip -Blue
- Pair 2 : White/Orange Strip -Orange
- Pair 3 : White/Green Strip-Green
- Pair 4 : White/Brown Strip -Brown

Standard Length & Packing:

305m Spool Dimension (FxBxT) : 14 x 6 x 12 Inch

Electrical Characteristics:

Conductor Resistance @20 deg.	Max. 9.38 Ω/100m
Conductor Resistance Unbalance	Max. 5 %
Mutual Capacitance	Max. 5.6 nF/100m
Capacitance Earth Unbalance	Max. 330 pF/100m
Insulation Resistance	Min. 5000 M.Ohm km
Dielectric Strength	DC 2500V/2s
Propagation Delay @ 1 , 10 , 100 & 500 MHz	Max. 570, 545, 538 & 536 ns/100 m
Velocity of Propagation	69%(nom)
Propagation DeLay Skew 1 –500 MHz	Max. 45 ns/100 m

Technical Details

Freq (MHZ)	Attenuation (dB/100m)	NEXT (dB)	PSNEXT (dB)	ACRF (ELFEXT) (dB)	PSACRF [PSELFEXT] (dB)	Return Loss (dB)
Max.	Min.	Min.	Min.	Min.	Min.	
1	2.3	65	62	63.3	60.3	19
4	4.2	63	60.5	51.2	48.2	19
8	5.8	58.2	55.6	45.2	42.2	19
10	6.5	56.6	54	43.3	40.3	19
16	8.2	53.2	50.6	39.2	36.2	18
20	9.2	51.6	49	37.2	34.2	17.5
25	10.2	50	47.3	35.3	32.3	17
31.25	11.5	48.4	45.7	33.4	30.4	16.5
62.5	16.4	43.4	40.6	27.3	24.3	14
100	20.9	39.9	37.1	23.3	20.3	12
200	30.1	34.8	31.9	17.2	14.2	9
250	33.9	33.1	30.2	15.3	12.3	8
300	37.4	31.7	28.8	13.7	10.7	7.2
400	43.7	28.7	25.8	11.2	8.2	6
500	49.3	26.1	23.2	9.3	6.3	6

Note: Supplied cable shall be passed Fluke Channel Test as per ANSI/TIA 568-C.2

Mechanical Properties:

Bending radius	: 8 x overall diameter (min.)
Breaking strength	: 400 N (max.)

Thermal Characteristics:

Operating Temperature	: - 20°C to +60°C
Installation Temperature	: -0°C to +50°C
Flammability	: IEC 60332-1-2

4 PAIR CAT6A 23AWG UTP ARMoured CABLE



Indoor



Flame Resistant



RoHS compliant

Applications

Cat6A UTP Cable 4 Pairs is suitable for Horizontal Cabling Systems. Used to transmit High Speed Data, Voice and Video signals both digital & analog through entire CHANNEL. With 500 MHz operational bandwidth it well exceeds the requirement of ANSI/TIA 568-C.2 and ISO 11801.

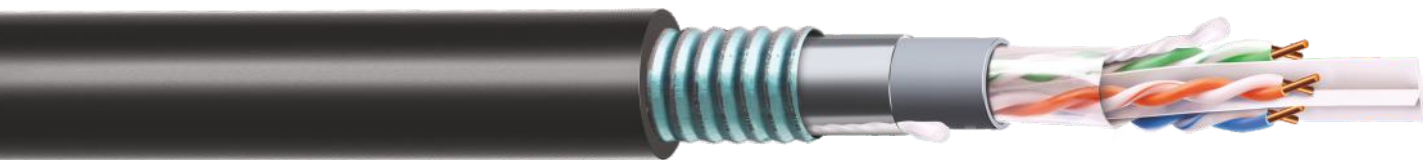

Typical Cross section

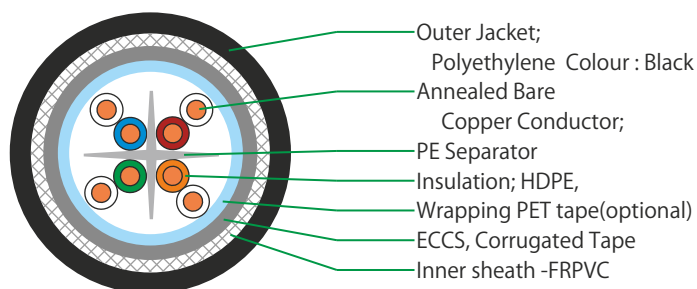

Electrical Characteristics:

Conductor Resistance	Max 9.38 Ω/100m
Conductor Resistance Unbalance	Max. 5 %
Mutual Capacitance	Max. 5.6 nF/100m
Capacitance Earth Unbalance	Max. 330 pF/100m
Insulation Resistance	Min. 5000 M.Ohm km
Dielectric Strength	2.5 Kv DC/2s
Characteristics Impedance:	100 ± 15Ω
Velocity of propagation	69%(nom)
Propagation Delay Skew 1 – 500 MHz	Max. 45 ns/100 m

Description:

Conductor	: 23AWG Solid Annealed Bare Copper Conductor
Insulation	: High Density Polyethylene,
Pairs	: Two Insulated conductors Twisted together to form pair
Twisting	: 4 pairs laid together and separated by PE Cross element
Wrapping	: Overall PET tape
Inner Sheath	: PVC, thickness 0.4mm(min)
Armour	: ECCS, Corrugated Tape ; > 0.125mm
Jacket	: PE - Black
Cable Diameter	: 11.5 ± 0.5 mm

Features:

- Reference standard TIA/EIA 568 C.2 (Category 6a) & ISO/IEC 11801 2nd ed(Class Ea)
- Packaged in Wooden Spool.
- True 23 AWG Solid Bare Copper
- 305 Meters Reel. 500 Meters Reel in Option
- 50m Channel" Performance Warranty

Colour Code:

- Pair 1 : White/Blue Strip -Blue
- Pair 2 : White/Orange Strip -Orange
- Pair 3 : White/Green Strip-Green
- Pair 4 : White/Brown Strip -Brown

Standard Length & Packing:

305m Spool Dimension (LxBxH) : 24 x14x14 Inch

Technical Details

Freq (MHZ)	Attenuation (dB/100m)	NEXT (dB)	PSNEXT (dB)	ACRF (ELFEXT) (dB)	PSACRF (PSELFEXT) (dB)	Return Loss (dB)
Max.	Min.	Min.	Min.	Min.	Min.	
1	2.3	65	62	63.3	60.3	19
4	4.2	63	60.5	51.2	48.2	19
8	5.8	58.2	55.6	45.2	42.2	19
10	6.5	56.6	54	43.3	40.3	19
16	8.2	53.2	50.6	39.2	36.2	18
20	9.2	51.6	49	37.2	34.2	17.5
25	10.2	50	47.3	35.3	32.3	17
31.25	11.5	48.4	45.7	33.4	30.4	16.5
62.5	16.4	43.4	40.6	27.3	24.3	14
100	20.9	39.9	37.1	23.3	20.3	12
200	30.1	34.8	31.9	17.2	14.2	9
250	33.9	33.1	30.2	15.3	12.3	8
300	37.4	31.7	28.8	13.7	10.7	7.2
400	43.7	28.7	25.8	11.2	8.2	6
500	49.3	26.1	23.2	9.3	6.3	6

Note: Supplied cable shall be passed Fluke Channel Test as per ANSI/TIA 568-C.2

Mechanical Properties:

Maximum tensile strength of jacket (N/mm ²):	13.1
Minimum Bending radius	: 20x Diameter (mm)@-20°C
Pulling Force	: 115 N (max.)

Thermal Characteristics:

Operating Temperature	: - 20°C to +60°C
Installation Temperature	: - 20°C to +60°C

4 PAIR CAT 6A 23AWG S/FTP LSZH CABLE



Indoor



Flame Resistant



RoHS compliant

Applications

These structure cable suitable for Gigabyte Ethernet Applications and compatible with all known connection Systems, Ideal for high performance workstation applications including voice/data systems, Digital video, Broadband and Voice over internet protocol etc. 10Base-T; 100Base-T; 1000Base-T; 10GBase-T



Typical Cross section

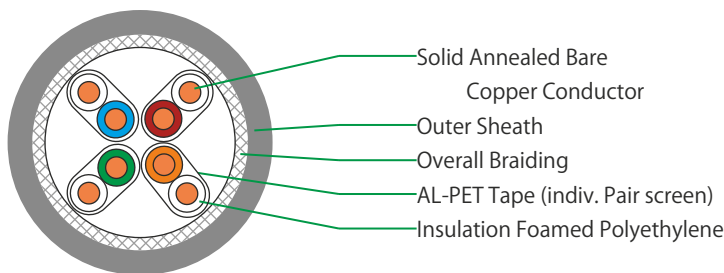

- Solid Annealed Bare Copper Conductor
- Outer Sheath
- Overall Braiding
- AL-PET Tape (indiv. Pair screen)
- Insulation Foamed Polyethylene

Electrical Characteristics:

Conductor Resistance	Max. 9.38 Ω/100m
Conductor Resistance Unbalance	Max. 5 %
Capacitance Earth Unbalance	Max. 1600 pF/Km
Insulation Resistance@500VDC	Min. 5000 M.Ohm km
Dielectric Strength	DC 1500V/2s
VOP	Nom 70%
Propagation Delay Skew	Max. 45 ns/100 m
Characteristics Impedance	100 Ω, ± 25 Ω

Description:

Conductor	: 23AWG Solid Annealed Bare Copper Conductor
Insulation	: Foam Polyethylene, nominal diameter 1.35mm
Pair Screening	: Each pair wrapped with Aluminium/Polyester (Mylar) Tape
Laid Up	: Four Individually Screened pairs stranded into cable core
Overall Screening	: Al Alloy/ATC braiding +ATC drain wire, coverage ≥30%
Outer Sheathing	: PE/LSZH/PVC per request,
Colour	: Grey / black or per request
Cable Diameter	: 7.3 ± 0.50 mm

Features:

- TIA/EIA 568 C.2 (Category 6a) & ISO/IEC 11801 2nd ed(Class Ea)
- Packaged in wooden Spool.
- Cable Characterized up to 500 MHz,
- Performance Designed to Support 10GB/S Ethernet requirements
- Individually Screened pairs.

Colour Code:

- Pair 1 : White/Blue Strip -Blue
- Pair 2 : White/Orange Strip -Orange
- Pair 3 : White/Green Strip-Green
- Pair 4 : White/Brown Strip -Brown

Standard Length & Packing:

305m Spool Dimension(FxBxT) : 14x 16x12 Inch

Technical Details

Freq (MHZ)	Attenuation (dB/100m)	NEXT (dB)	PSNEXT (dB)	ACRF (ELFEXT) (dB)	PSACRF (PSELFEXT) (dB)	Return Loss (dB)
Max.	Min.	Min.	Min.	Min.	Min.	
1	2.3	65	62	63.3	60.3	19
4	4.2	63	60.5	51.2	48.2	19
8	5.8	58.2	55.6	45.2	42.2	19
10	6.5	56.6	54	43.3	40.3	19
16	8.2	53.2	50.6	39.2	36.2	18
20	9.2	51.6	49	37.2	34.2	17.5
25	10.2	50	47.3	35.3	32.3	17
31.25	11.5	48.4	45.7	33.4	30.4	16.5
62.5	16.4	43.4	40.6	27.3	24.3	14
100	20.9	39.9	37.1	23.3	20.3	12
200	30.1	34.8	31.9	17.2	14.2	9
250	33.9	33.1	30.2	15.3	12.3	8
300	37.4	31.7	28.8	13.7	10.7	7.2
400	43.7	28.7	25.8	11.2	8.2	6
500	49.3	26.1	23.2	9.3	6.3	6

Note: Supplied cable shall be passed 70m Fluke

Mechanical Properties:

Bending radius	: 8 x overall diameter (min.)
Pulling Force	: Max 130 N

Thermal Characteristics:

Operating Temperature	: -20°C to +60°C
Installation Temperature	: -0°C to +50°C
Flammability Test	: IEC 60332-1
Acid Gas Emission Test	: IEC 60754-1 & 2
Smoke Density Test	: IEC 61034-2

4 PAIR CAT6A 23AWG SFTP CABLE



Indoor



Flame Resistant



RoHS compliant

Applications

These structure cable suitable for 10Gigabyte Ethernet Applications and compatible with all known connection Systems, Ideal for high performance workstation applications including voice/data systems, Digital video, Broadband and Voice over internet protocol etc.



Typical Cross section

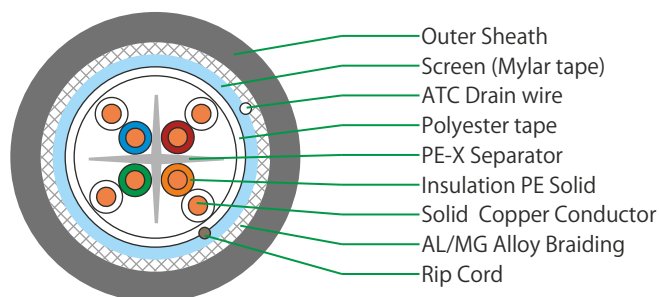

Electrical Characteristics:

Conductor Resistance @20°C	Max. 9.38 Ω/km
Conductor Resistance Unbalance	Max.5 %
Capacitance Earth Unbalance	Max. 330 pF/100m
Insulation Resistance @ 500VDC	Min. 5000 M.Ohm km
Dielectric Strength(cond, - cond)	2.5kVdc/2s
Nominal velocity of Propagation	69%
Characteristic Impedance	100 ± 15Ω
Propagation Delay Skew 1 –500 MHz	Max. 45 ns/100 m

Description:

Conductor	: 23AWG Solid Annealed Bare Copper Conductor
Insulation	: HDPE Compound
Pairs	: Two Insulated conductors Twisted together to form pair
No. of Pair	: 4 pairs laid together and Separated by Polyethylene Cross element
Core Wrapping	: Overall PET tape
Shielding	: Overall Aluminium/Polyester foil + tinned copper drain wire -26AWG
Braiding	: AL/MG Alloy Or ATC Braiding
Outer Sheathing	: LSZH/PVC /PE Compound, per request
Colour	: Grey/Black or per request
Cable Diameter	: 7.5 ± 0.5 mm

Features:

- Generally meet to the requirements of TIA/EIA 568 C.2, ISO/ IEC 11801 – 2nd Edition
- Cable Characterized up to 500 MHz,
- Overall AL Mylar tape Screen
- Overall AL/MG Alloy Braiding.
- LSZH; IEC 60332-1, IEC 60754, IEC 61034-2

Colour Code:

- Pair 1 : White/Blue Strip -Blue
- Pair 2 : White/Orange Strip -Orange
- Pair 3 : White/Green Strip-Green
- Pair 4 : White/Brown Strip -Brown

Standard Length & Packing:

305m Spool Dimension (FxBxT) : 14 x 6 x 12 Inch

Technical Details

Freq (MHZ)	Attenuation (dB/100m)	NEXT (dB)	PSNEXT (dB)	ACRF (ELFEXT) (dB)	PSACRF [PSELFEXT] (dB)	Return Loss (dB)
Max.	Min.	Min.	Min.	Min.	Min.	
1	2.3	65	62	63.3	60.3	19
4	4.2	63	60.5	51.2	48.2	19
8	5.8	58.2	55.6	45.2	42.2	19
10	6.5	56.6	54	43.3	40.3	19
16	8.2	53.2	50.6	39.2	36.2	18
20	9.2	51.6	49	37.2	34.2	17.5
25	10.2	50	47.3	35.3	32.3	17
31.25	11.5	48.4	45.7	33.4	30.4	16.5
62.5	16.4	43.4	40.6	27.3	24.3	14
100	20.9	39.9	37.1	23.3	20.3	12
200	30.1	34.8	31.9	17.2	14.2	9
250	33.9	33.1	30.2	15.3	12.3	8
300	37.4	31.7	28.8	13.7	10.7	7.2
400	43.7	28.7	25.8	11.2	8.2	6
500	49.3	26.1	23.2	9.3	6.3	6

Note: Supplied cable shall be 70m passed Fluke Channel Test as per ANSI/TIA 568-C.2.

Mechanical Properties:

Bending radius	: 8 x overall diameter (min.)
Pulling Force	: Max 115 N

Thermal Characteristics:

Installation Temperature	: 0°C to +50°C
Storage Temperature	: - 10°C to +60°C
Operating Temperature	: - 10°C to +60°C

4PAIR CAT6A 23AWG F/UTP CABLE



Indoor



Flame Resistant



RoHS compliant

Applications

These structure cable suitable for 10Gigabyte Ethernet Applications and compatible with all known connection Systems, Ideal for high performance workstation applications including voice/data systems, Digital video, Broadband and Voice over internet protocol etc.



Typical Cross section

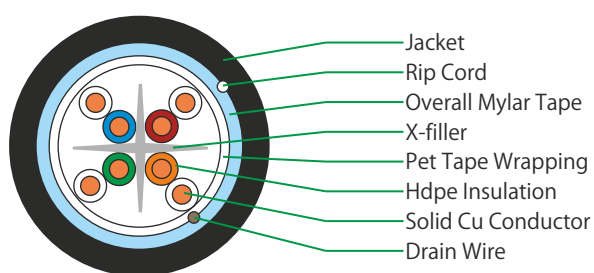

Description:

Conductor	: 23AWG Solid Annealed Bare Copper Conductor
Insulation	: Polyethylene(HDPE), diameter 1.10 ± 0.05mm
Pair Screening	: Two Insulated conductors Twisted together to form pair
Laid Up	: Four pairs stranded over X-Filler into cable core
Drain Wire	: Annealed Tinned Copper Conductor- 26AWG
Overall Screening	: AL/PET Mylar tape
Outer Sheathing	: PVC/LSZH, Grey
Cable Diameter	: 7.5 ± 0.50 mm

Features:

- TIA/EIA 568 C.2 (Category 6a) & ISO/IEC 11801 2nd ed(Class Ea)
- Packaged in wooden spool-305m.
- Cable Characterized up to 500 MHz,
- Performance Designed to Support 10GB/S Ethernet requirements
- Over all AL/PET Mylar tape shielding.

Colour Code:

- Pair 1 : White/Blue Strip -Blue
- Pair 2 : White/Orange Strip -Orange
- Pair 3 : White/Green Strip-Green
- Pair 4 : White/Brown Strip -Brown

Standard Length & Packing:

L305m Spool Dimension (FxBxT) : 14 x 6 x 12 Inch

Electrical Characteristics:

Conductor Resistance @20 deg.	Max. 9.38 Ω/100m
Conductor Resistance Unbalance	Max. 5 %
Mutual Capacitance	Max. 5.6 nF/100m
Capacitance Earth Unbalance	Max. 330 pF/100m
Insulation Resistance@500vdc	Min. 5000 MOhm. km
Dielectric Strength	DC 2500V/2s
Propagation Delay Skew 1 –500 MHz	Max. 50 ns/100 m

Technical Details

Freq (MHZ)	Attenuation (dB/100m)	NEXT (dB)	PSNEXT (dB)	ACRF (ELFEXT) (dB)	PSACRF [PSELFEXT] (dB)	Return Loss (dB)
Max.	Min.	Min.	Min.	Min.	Min.	
1	2.3	65	62	63.3	60.3	19
4	4.2	63	60.5	51.2	48.2	19
8	5.8	58.2	55.6	45.2	42.2	19
10	6.5	56.6	54	43.3	40.3	19
16	8.2	53.2	50.6	39.2	36.2	18
20	9.2	51.6	49	37.2	34.2	17.5
25	10.2	50	47.3	35.3	32.3	17
31.25	11.5	48.4	45.7	33.4	30.4	16.5
62.5	16.4	43.4	40.6	27.3	24.3	14
100	20.9	39.9	37.1	23.3	20.3	12
200	30.1	34.8	31.9	17.2	14.2	9
250	33.9	33.1	30.2	15.3	12.3	8
300	37.4	31.7	28.8	13.7	10.7	7.2
400	43.7	28.7	25.8	11.2	8.2	6
500	49.3	26.1	23.2	9.3	6.3	6

Note: Supplied cable shall be 70m passed Fluke Channel Test as per ANSI/TIA 568-C.2.

Mechanical Properties:

Bending radius	: 8 x overall diameter (min.)
Pulling Force	: Max 110 N

Thermal Characteristics:

Operating Temperature	: - 20°C to + 60°C
Installation Temperature	: -0°C to +50°C
Flammability	: IEC 60332-1-2

4 PAIR CAT 5E 24AWG UTP DROP CABLE



Indoor



Flame Resistant



RoHS compliant

Applications

These are structured cables suitable for Ethernet Applications and compatible with all known connection Systems. Ideal for high performance workstation applications including voice/data systems, Digital video, Broadband and Voice over internet protocol etc. These are drop cables used for broadband connectivity in residential buildings/houses, inter-building cabling etc.



Typical Cross section

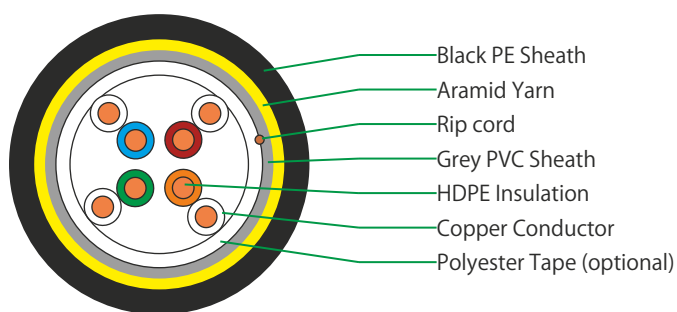

Description:

Conductor	: 24AWG Solid bare copper
Insulation	: HDPE
Pairing	: Twisted insulated conductor
Laid Up	: 4 Pair
Wrapping	: Overall PET tape
Inner sheath	: PVC
Strength member	: Aramid Yarn
Outer Sheathing	: PE
Cable Diameter	: 6.0 ± 0.5 mm

Features:

- Good Mechanical Protection
- Suitable for use outside buildings & UV resistant outer Sheath.
- Performance Specification up to 100 MHz.

Colour Code:

- Pair 1 : White/Blue Strip -Blue
- Pair 2 : White/Orange Strip -Orange
- Pair 3 : White/Green Strip -Green
- Pair 4 : White/Brown Strip -Brown

Standard Length & Packing:

305 meter Coils in pull out box.

Electrical Characteristics:

Conductor Resistance :	Max. 9.38 Ω/100m
Conductor Resistance Unbalance:	Max. 5 %
Mutual Capacitance :	Max. 5.6 nF/100m
Capacitance Earth Unbalance:	Max. 330 pF/100m
Characteristics Impedance at 1 – 100 MHz:	100 ± 15 Ω
Propagation Delay @ 1 MHz, 10 MHz & 100 MHz;	Max. 570, 545, 538 ns/100 m
Propagation Delay Skew 1 – 100 MHz	Max. 45 ns/100 m
Velocity of Propagation @ 1 MHz, 10 MHz & 100 MHz:	Min. 58.5, 61.1, 62.0 %

Technical Details

Freq (MHZ)	Attenuation (dB/100m)	NEXT (dB)	PSNEXT (dB)	ACRF (ELFEXT) (dB)	PSACRF (PSELFEXT) (dB)	Return Loss (dB)
Max.	Min.	Min.	Min.	Min.	Min.	
1.0	17.0	2.2	60.0	57.0	57.4	54.4
4.0	17.0	4.5	53.5	50.5	45.4	42.4
8.0	17.0	6.3	48.6	45.6	39.3	36.3
10.0	17.0	7.1	47.0	44.0	37.4	34.4
16.0	17.0	9.1	43.6	40.6	33.3	30.3
20.0	17.0	10.2	42.0	39.0	31.4	28.4
25.0	16.0	11.4	40.3	37.3	29.4	26.4
31.25	15.1	12.9	38.7	35.7	27.5	24.5
62.5	12.1	18.6	33.6	30.6	21.5	18.5
100	10.0	24.0	30.1	27.1	17.4	14.4

Note: Supplied cable Guaranteed to Pass Fluke channel Test

4 PAIR CAT 5E 24AWG UTP CABLE



Indoor



Flame Resistant



RoHS compliant

Applications

These structure cable suitable for Ethernet Applications and compatible with all known connection Systems, Ideal for high performance workstation applications including voice/data systems, Digital video, Broadband and Voice over internet protocol etc.



Typical Cross section

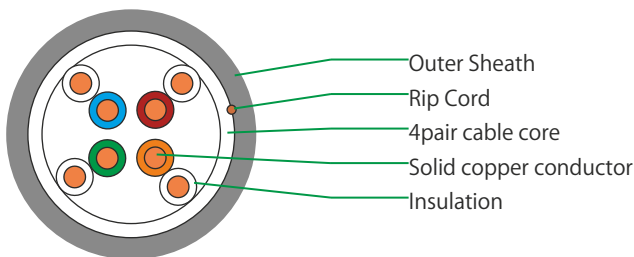

Electrical Characteristics:

Conductor Resistance	Max 9.38 Ω/100m
Conductor Resistance Unbalance	Max 2 %
Mutual Capacitance	Max 5.6 nF/100m
Capacitance Earth Unbalance	Max 160 pF/100m
Propagation Delay @ 1, 10, 100 MHz	Max. 570, 545, 538 ns/100 m
Propagation DeLay Skew 1 – 100MHz	Max. 45 ns/100 m
Characteristic Impedance (1-100MHz)	100 ± 15Ω

Description:

Conductor	24 AWG Solid Bare Copper conductor
Insulation	High Density Polyethylene, Diameter 0.88 ± 0.05mm
Pairs	Two Insulated conductors Twisted together to form pair
Twisting	4 pairs laid together
Sheath	PVC/LSZH
Colour	Grey or per request
Cable Diameter	5.0 ± 0.5 mm

Features:

- Generally complied requirements of ISO 11801 Class D or TIA/EIA 568 C.2 Category 5e
- Cable Characterized up to 100 MHz,
- Packaged in Cardboard Box.
- Flammability; IEC60332-1-2
- Suitable for Indoor Installation.

Colour Code:

Pair 1	: White/Blue Strip -Blue
Pair 2	: White/Orange Strip -Orange
Pair 3	: White/Green Strip -Green
Pair 4	: White/Brown Strip -Brown

Standard Length & Packing:

305m Box Dimension (LxBxH): 14X8X14 Inch

Technical Details

Freq (MHZ)	Attenuation (dB/100m)	NEXT (dB)	PSNEXT (dB)	ACRF (ELFEXT) (dB)	PSACRF (PSELFEXT) (dB)	Return Loss (dB)
Max.	Min.	Min.	Min.	Min.	Min.	
1.0	17.0	2.2	60.0	57.0	57.4	54.4
4.0	17.0	4.5	53.5	50.5	45.4	42.4
8.0	17.0	6.3	48.6	45.6	39.3	36.3
10.0	17.0	7.1	47.0	44.0	37.4	34.4
16.0	17.0	9.1	43.6	40.6	33.3	30.3
20.0	17.0	10.2	42.0	39.0	31.4	28.4
25.0	16.0	11.4	40.3	37.3	29.4	26.4
31.25	15.1	12.9	38.7	35.7	27.5	24.5
62.5	12.1	18.6	33.6	30.6	21.5	18.5
100	10.0	24.0	30.1	27.1	17.4	14.4

Note: Supplied cable Guaranteed to Pass Fluke channel Test

Mechanical Properties:

Bending radius	: 4 x overall diameter (min.)
Breaking Strength	: 400 N (max.)

Thermal Characteristics:

Temperature Range	: -10°C up to + 60°C
-------------------	----------------------

4PAIR CAT 5E 24AWG SF/UTP CABLE



Indoor



Flame Resistant



RoHS compliant

Applications

These structure cable suitable for Ethernet Applications and compatible with all known connection Systems, Ideal for high performance workstation applications including voice/data systems, Digital video, Broadband and Voice over internet protocol etc.



Typical Cross section

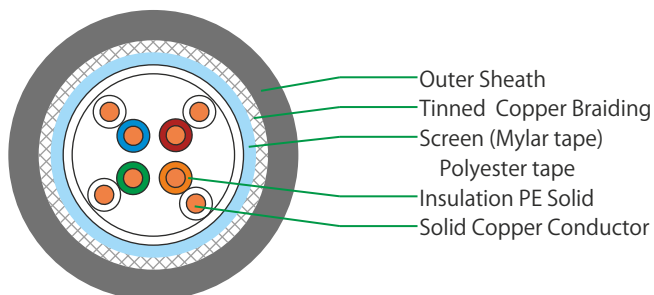

Description:

- Conductor : 24 AWG Solid Bare Copper conductor
- Insulation : Diameter 0.92 ± 0.05mm
- Pairs : Two Insulated conductors Twisted together to form pair
- Twisting : 4 pairs laid together
- Core Wrapping : Overall PET tape
- Shielding: : Overall AL-PET Tape (Mylar)+Tinned copper conductor braiding.
- Sheathing : Extruded PVC/LSZH Compound
- Colour : Grey/black or per request
- Cable Diameter : 6.5 ± 0.50 mm

Features:

- Generally Complies to TIA/EIA 568 C.2 ,ISO/ IEC 11801 – 2nd Edition ,
- Cable Characterized up to 100 MHz,
- Overall Mylar tape Screen
- Overall Tinned copper conductor braiding.
- Flammability of Sheath IEC 60332-1-2

Colour Code:

- Pair 1 : White/Blue Strip -Blue
- Pair 2 : White/Orange Strip -Orange
- Pair 3 : White/Green Strip-Green
- Pair 4 : White/Brown Strip -Brown

Standard Length & Packing:

305m Box Dimension (LxBxH): 13X6X14 Inch

Electrical Characteristics:

Conductor Resistance	Max. 9.38 Ω/100m
Conductor Resistance Unbalance	Max.5 %
Mutual Capacitance	Max. 5.6 nF/100m
Capacitance Earth Unbalance	Max. 330 pF/100m
Propagation Delay @ 1, 10, 100 MHz	Max. 570, 545, 538 ns/100 m
Propagation Delay Skew 1 – 100MHz	Max. 45 ns/100 m
Dielectric strength	2000VDC/2s
Insulation resistance	5000 MΩ.km
NVP	62%(nom)
Characteristic Impedance (1-100MHz)	100 ± 15Ω

Technical Details

Freq (MHZ)	Attenuation (dB/100m)	NEXT (dB)	PSNEXT (dB)	ACRF (ELFEXT) (dB)	PSACRF [PSELFEXT] (dB)	Return Loss (dB)
Max.	Min.	Min.	Min.	Min.	Min.	
1	2.3	65	62	63.3	60.3	19
4	4.2	63	60.5	51.2	48.2	19
8	5.8	58.2	55.6	45.2	42.2	19
10	6.5	56.6	54	43.3	40.3	19
16	8.2	53.2	50.6	39.2	36.2	18
20	9.2	51.6	49	37.2	34.2	17.5
25	10.2	50	47.3	35.3	32.3	17
31.25	11.5	48.4	45.7	33.4	30.4	16.5
62.5	16.4	43.4	40.6	27.3	24.3	14
100	20.9	39.9	37.1	23.3	20.3	12

Note: Supplied cable Guaranteed to Pass Fluke channel Test

Mechanical Properties:

- Bending radius : 8 x overall diameter (min.)
- Pulling Force : Max 115 N

Thermal Characteristics:

- Operating Temperature : - 20°C to +70°C

4PAIR CAT 5E 24AWG F/UTP CABLE



Indoor



Flame Resistant



RoHS compliant

Applications

These structure cable suitable for Ethernet Applications and compatible with all known connection Systems, Ideal for high performance workstation applications including voice/data systems, Digital video, Broadband and Voice over internet protocol etc.



Typical Cross section

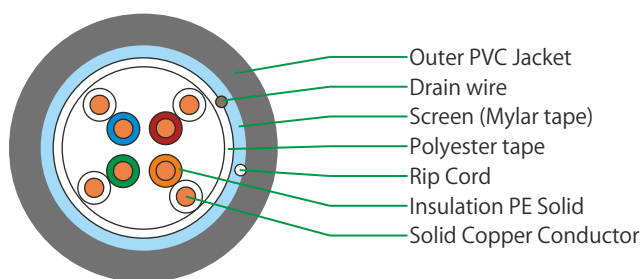

Description:

Conductor	: 24 AWG Solid Bare Copper conductor
Insulation	: HDPE, diameter -1.0± 0.05mm
Pairs	: Two Insulated conductors Twisted together to form pair
Twisting	: 4 pairs laid together
Core Wrapping	: Overall PET tape
Shielding:	: Overall AL-PET Tape (Mylar),
Drain wire	: Solid Tinned copper drain wire
Rip Cord	: Yes
Jacketing	: Extruded PVC/LSZH
Jacket Minimum Average Thickness	: 0.50mm
Jacket Colour	: Grey/Black or per request
Cable Diameter	: 6.3 ± 0.4 mm

Features:

- Reference Standard: ISO/IEC 11801 & TIA/EIA-568-C.2, IEC61156-5
- Cable Characterized up to 100 MHz,
- Overall Mylar tape Screen
- Tinned copper conductor Drain wire.
- Flammability IEC 60332-1-2

Colour Code:

Pair 1	: White -Blue
Pair 2	: White -Orange
Pair 3	: White -Green
Pair 4	: White -Brown

Standard Length & Packing:

305m Box Dimension (LxBxH): 13X6X14 Inch

Electrical Characteristics:

Conductor Resistance	Max. 9.38 Ω/100m
Resistance Unbalance(within Pair)	Max 5 %
Mutual Capacitance	Max 5.6 nF/100m
Capacitance Earth Unbalance	Max 160 pF/100m
Dielectric strength	2.5kv dc for 2sec
Insulation resistance @500v dc, 1minute	5000 Mohm.km
Propagation Delay Skew 1 – 100MHz	Max. 50 ns/100 m
Characteristic Impedance (1-100MHz)	100 ± 15Ω

Technical Details

Freq (MHZ)	Attenuation (dB/100m)	NEXT (dB)	PSNEXT (dB)	ACRF (ELFEXT) (dB)	PSACRF [PSELFEXT] (dB)	Return Loss (dB)
Max.	Min.	Min.	Min.	Min.	Min.	
1	2.3	65	62	63.3	60.3	19
4	4.2	63	60.5	51.2	48.2	19
8	5.8	58.2	55.6	45.2	42.2	19
10	6.5	56.6	54	43.3	40.3	19
16	8.2	53.2	50.6	39.2	36.2	18
20	9.2	51.6	49	37.2	34.2	17.5
25	10.2	50	47.3	35.3	32.3	17
31.25	11.5	48.4	45.7	33.4	30.4	16.5
62.5	16.4	43.4	40.6	27.3	24.3	14
100	20.9	39.9	37.1	23.3	20.3	12

Note: Supplied cable Guaranteed to Pass Fluke channel Test

Mechanical Properties:

Bending radius : 4 x overall diameter (min.)

Thermal Characteristics:

Operating Temperature : - 20°C to +70°C
 Flammability : IEC 60332-1-2

**SWITCHBOARD CABLES
(SCREENED / UNSCREENED)**



Applications

These Cables are used for Internal wiring in Telephone Exchanges , bay-to-bay wiring, equipment to MDF wiring etc and in subscriber offices in large buildings.

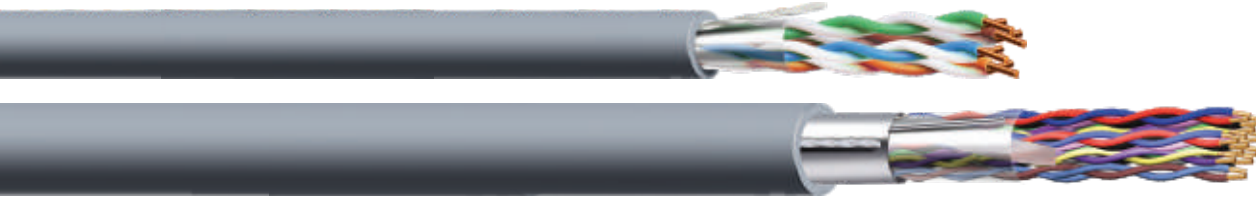

Typical Cross section for Armoured Cable

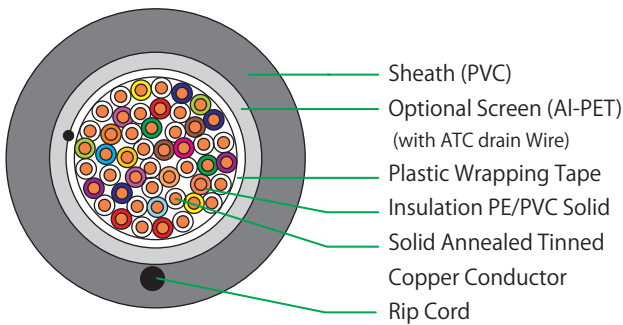

Features:

- Available in standard conductor sizes of 0.4mm, 0.5mm & 0.6mm Diameter.
- Available in 1 Pair to 128Pair & more if required.
- Meets the flammability test requirement as per IEC 332 (Part-1)
- TEC approved cable as per GR/WIR-06/03 Mar 2002

Electrical Characteristics:

Conductor Resistance 0.4mm	Max. 143 Ω/Km
0.5mm	Max 92.2 Ω/Km
0.6mm	Max 64.0 Ω/Km
Capacitance Unbalance (Pair to Pair)	Max. 230 pF/Km
Insulation Resistance at 50° C	Min. 50 M Ω Km
Dielectric Strength	3.0 KV DC, 1 Minute

Environmental Properties:

Operating Temperature	- 20° C to + 75° C
Flameability	IEC 332 (Part 1)

Standard Length & Packing:

As per customer requirement.
Wound & Packed in Wooden Drums / Coils / Spools as per size and standard length

Colour Code:

For Insulation of

1 Pair / 2 Pair/ 3 Pair / 4 Pair / 5 Pair / 10 Pair / 20 Pair Unit

Pair 1: White-Blue	Pair 11: Black-Blue
Pair 2: White-Orange	Pair 12: Black-Orange
Pair 3: White-Green	Pair 13: Black-Green
Pair 4: White-Brown	Pair 14: Black-Brown
Pair 5: White-Grey	Pair 15: Black-Grey
Pair 6: Red-Blue	Pair 16: Yellow-Blue
Pair 7: Red-Orange	Pair 17: Yellow-Orange
Pair 8: Red-Green	Pair 18: Yellow-Green
Pair 9: Red-Brown	Pair 19: Yellow-Brown
Pair 10: Red-Grey	Pair 20: Yellow-Grey

For Insulation Of 8 Pair

Pair 1: White-Blue	Pair 5: Red-Blue
Pair 2: White-Orange	Pair 5: Red-Orange
Pair 3: White-Green	Pair 7: Red-Green
Pair 4: White-Brown	Pair 8: Red-Brown

For 8 Pair Sub-unit Binder Colours of 32 Pair

Binder 1: Blue	Pair 3: Green
Binder 2: Orange	Pair 4: Brown

For 32 Pair Unit Binder Colours of 128 Pair

Binder 1: White	Pair 3: Black
Binder 2: Red	Pair 4: Yellow

SCREENED PCM CABLES

Solid / Foam Skin Insulated, Individual Screened Twisted Pairs, PVC Sheathed, Overall Screened Telecommunication Cables



Applications:

- Digital equipment wiring to work up to 2 M bits/sec.



Typical Cross section for Armoured Cable

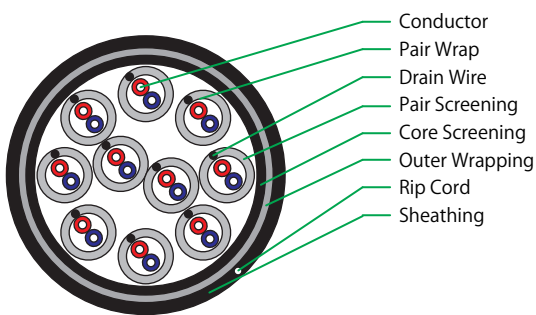

Electrical Characteristics:

Resistance

Conductor Resistance at 20°C (Ω/Km)	86 ± 3
Resistance Unbalance (%)	2.5 (Max. Indiv.) 1.0(Max. Avg.)

Insulation Resistance at 500 V Dc(M Ω Km)

10,000

Dielectric Strength

4. 2.4 KV Dc for 3 seconds

With stands

Capacitance

Mutual capacitance at 1 KHz (nF/Km)	45 ± 5
Earth capacitance unbalance (pF/500m)	2000 (Max.)

Impedance

Characteristics impedance at 1 MHZ (Ω)	120 ± 10
--	----------

Attenuation

Attenuation at 20° c at 1 MHZ (dB/Km)	20 dB/Km (Max.)
---------------------------------------	-----------------

Cross Talk [pair to pair within unit]

Near end cross talk at 1 MHZ (dB)	85 (Min.)
Far end cross talk at 1 MHZ (dB/Km)	67 (Min.)

Features:

- Available in standard conductor sizes of 0.5mm diameter.
- Available in 1 Pair to 16 Pair and more if required.
- Meets the flammability test requirement as per IEC 332 (Part-1)
- TEC approved cable as per GR/WIR-04/02 Nov 2001
- Excellent protection to cross-talk and Electromagnetic Induction

Colour Coding

Each pair shall be Red for Wire-1 and Blue for Wire-2, with serial number of the pair viz. 1 to 10/16, marked at regular interval, on the outer surface of the Aluminium film used for Pair Screening.

Cable Diameter , Standard Length & Packing:

Cable Diameter	: 10 P: 15 mm (Maximum) 16 P: 18 mm (Maximum)
Standard Length	: 500 mtr ± 10%
Packing	: Wound and packed in wooden drums

50 Ohm COAXIAL CABLE

Foamed PE insulated copper conductor, Al foil shield & braid screened Coaxial cable, PE outer sheathed.



Outdoor



Underground



Applications

This is a 50 Ohm Coaxial Cable for telecommunication intended for outdoor use with the frequency range of 4 Ghz.



Typical Cross section

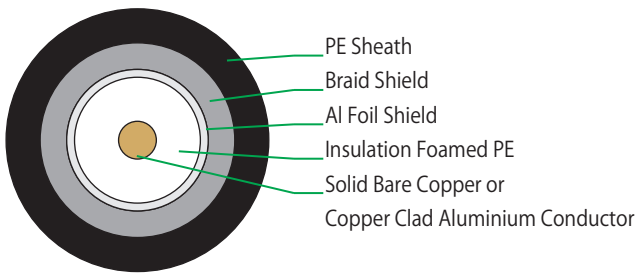

Electrical Characteristics:

Characteristics Impedence	50 ± 2Ω
Velocity of propagation	85%
Capacitance	78 nF/ Km
Loop Resistance	Max. 19.0Ω/ Km
Attenuation at 140, 350, 900, 1800 & 2000 MHz	≤ 12, 18, 23, 32 ,34 dB /100 Mtr.
Dielectric Strength	Withstands 1.5 KV, 2 sec.

Cable Diameter , Standard Length & Packing:

Cable Diameter : 7.60 mm (Nominal)
 Available Packaging : 500 mtr ± 10% spools

AUTOMOBILE WIRES

These are PVC Insulated Single Core Thin-Wall type Low Voltage and Light Weight Auto Wires conforming to International DIN, JIS & JASO Standards. Range of Cables includes FLRY, AV, AVS and AVSS types.



Indoor



Flame Resistant



RoHS compliant

Applications

These wires are used in manufacturing of Wiring Harness for Automobile Industry where high flexibility, thermo and mechanical strength are required.



Typical Cross section

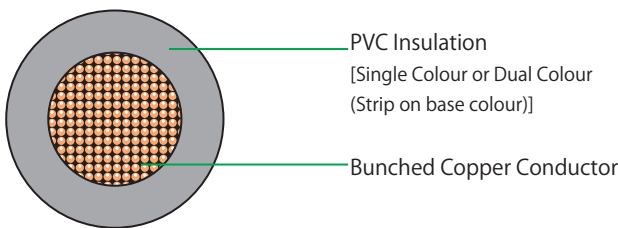

Features:

Manufactured within the Quality System certified as per TS 16949:2002

- Resistant to heat, oil, abrasion and cold.
- Excellent flexibility.
- Temperature Range of DIN Wires: -40° C to +105° C.
- Temperature Range of JIS & JASO Wires : -40° C to +85° C.
- Available in different colors and stripes.
- Available in Leaded or Lead free grades.
- Packed in Coils of suitable standard lengths.

AVSS Type Wires (JASO D 611)

Nominal Cross Section Sq mm	No. of Strands	Diameter of Single Wire Max mm	Diameter of Conductor Max mm	Electrical Resistance @ 20°C mΩ/m	Insulation Wall Thickness Min. mm	Cable Outer Diameter mm	Cable Weight Approx. Kg/Km
0.35	7	0.26	0.8	50.2	0.24	1.5	4.8
0.50	7	0.32	1.0	32.7	0.24	1.7	6.9
0.5f	19	0.19	1.0	34.6	0.24	1.7	6.7
0.75	7	0.39	1.8	22.3	0.24	1.8	9.4
0.75f	19	0.23	1.2	23.6	0.24	1.9	9.2
0.85	7	0.40	1.1	20.8	0.24	1.9	10.0
1.25	19	0.29	1.5	14.9	0.24	2.2	13.9
2.00	19	0.37	1.9	9.0	0.32	2.8	23.0
2.00 f	37	0.26	1.8	9.5	0.32	2.7	21.6

FLRY-B Type Wires (DIN 72551 Part 5 & 6)

Nominal Cross Section Sq mm	No. of Strands	Diameter of Single Wire Max mm	Diameter of Conductor Max mm	Electrical Resistance @ 20°C mΩ/m	Insulation Wall Thickness Min. mm	Cable Outer Diameter mm	Cable Weight Approx. Kg/Km
0.35	12	0.21	0.90	47.8 - 52.0	0.20	1.2 – 1.4	4.5
0.50	16	0.21	1.00	34.1 - 37.1	0.22	1.4 – 1.6	6.6
0.75	24	0.21	1.20	22.7 - 24.7	0.24	1.7 – 1.9	9.0
1.0	32	0.21	1.35	17.0 - 18.5	0.24	1.9 – 2.1	11.0
1.5	30	0.26	1.70	11.7 - 12.7	0.24	2.2 – 2.4	16.0
2.5	50	0.26	2.20	7.0 - 7.6	0.28	2.7 – 3.0	26.0
4.0	56	0.31	2.75	4.32 - 4.70	0.32	3.4 – 3.7	42.0
6.0	84	0.31	3.30	2.85 - 3.10	0.32	4.0 – 4.3	61.0
10.0	80	0.41	4.40	1.82 (Max)	0.48	5.5 – 6.0	109.0
16.0	126	0.41	5.50	1.16 (Max)	0.48	7.0 – 7.5	178.0

AVS Type Wires (JASO D 611)

Nominal Cross Section Sq mm	No. of Strands	Diameter of Single Wire Max mm	Diameter of Conductor Max mm	Electrical Resistance @ 20°C mΩ/m	Insulation Wall Thickness Min. mm	Cable Outer Diameter mm	Cable Weight Approx. Kg/Km
0.5	7	0.32	1.0	32.7	0.32	2.1	8.1
1.25	16	0.32	1.5	14.3	0.32	2.6	15.2
1.25f	50	0.18	1.5	14.7	0.32	2.6	14.9
2.00	26	0.32	1.9	8.81	0.32	3.1	23.3
3.00	41	0.32	2.4	5.59	0.40	3.8	37.6
5.00	65	0.32	3.0	3.52	0.48	4.6	58.6

AV Type Wires (JIS C 3406)

Nominal Cross Section Sq mm	No. of Strands	Diameter of Single Wire Max mm	Diameter of Conductor Max mm	Electrical Resistance @ 20°C mΩ/m	Insulation Wall Thickness Min. mm	Cable Outer Diameter mm	Cable Weight Approx. Kg/Km
0.5f	20	0.18	1.0	36.7	0.48	2.4	8.7
0.75f	30	0.18	1.20	24.4	0.48	2.6	11.0
0.85	11	0.32	1.20	20.8	0.48	2.6	12.0
2.00	26	0.32	1.90	8.81	0.48	3.4	24.9
3.00	41	0.32	2.40	5.59	0.56	4.1	39.6
5.00	65	0.32	3.00	3.52	0.64	4.9	60.0
8.00	50	0.45	3.70	2.32	0.72	5.8	89.5
10.0	65	0.45	4.25	1.80	0.80	6.5	115.7

*Complete Solutions
For All Needs*

EPC Division





We offer complete turnkey services for Engineering, design, supply, construction, installation, testing & commissioning for:

Telecom Sector

- Turnkey projects of Optical fibre cabling.
- Complete Infrastructure for Telecom Towers.
- Intracity HDD – Broadband network.

Power Sector

- EHV Cabling Projects.
- Rural Electrification projects.
- Transmission Lines.
- Transmission and Distribution substations.
- Lighting Projects.



*Strength beyond
Imagination*

FRP Rods



Fiber Reinforced Plastic (FRP Rod)

Used as Di electric composite strength member in Optic Fibre Cables

Applications

- It is a di-electric composite cable strength member widely known as FRP/GRP rod.
- It is designed to provide excellent tensile strength performance while maintaining high degree of stiffness, preventing cable buckling over its entire service life.
- It is most suited for loose tube, uni-tube, slotted core or ribbon cable, typically used as central or peripheral reinforcement in fiber optic cables.
- FRP rods serve a dual purpose.
- It provides cable reinforcement during installation, reduces tension on signal carrying optic fiber/ conductor.
- The lightweight FRP prevents the cable from sagging in aerial installations and its rigidity and strength takes on the load of cable.
- FRP combines the properties of high performance glass fibers and polymer resin to give a cost effective and superior strength member for cables.
- FRP strength members are also widely used in various copper cables for last mile connectivity as well as power transmission.

Features:

- Light Weight & Excellent Tensile Strength
- Prevent Cable buckling
- Most Suited for Multi-Loose Tube, Uni Tube, Slotted Core & Ribbon Cable Designs.
- Used as central or peripheral reinforcement in fibre optic cable
- Dual Advantage : Reinforcement during installation as well as reduce stress on signal carrying optic fibre /conductor
- Prevent sagging in aerial installation
- Cost effective solution as a strength member

Description

It is manufactured using E-glass fibre with heat resistant thermal resin system. It is available in various coatings including EAA, Tuff, Mega Bond and HDPE, which allows easy handling, Tuff coating provides very smooth surface, whereas Mega bond is suitable for where high adhesion to up jacketing is desired

Product Range

Available diameter:

0.4 mm up to 5.0 mm (0.4, 0.8, 0.9, 1.0, 1.1, 1.2, 1.5, 1.6, 1.8, 2.0, 2.1, 2.2, 2.3, 2.5, 2.7, 2.8, 3.0, 3.5, 4.0, 4.5, 5.0).

Physical Property

Glass content	75 to 85% by weight
Density	2.05 to 2.15 gms/ cc
Diameter stability	±0.05 mm of ordered diameter
Ovality	<(=)0.05 mm
Splices	None



Mechanical Property			
Property	Unit	Specification	Test Method
Tensile Strength at Break	Kg/mm ²	> 140	ASTM D 3916
Tensile modulus	Kg/mm ²	> 5000	ASTM D 3916
Elongation at break	%	> 2.5% & < 4%	ASTM D 3916
Flexural modulus	Kg/mm ²	> 5000	ASTM D 790
Flexural Strength	Kg/mm ²	> 70	ASTM D 790
Water Absorption after 24 hrs.	%	< 0.1	ASTM D 570
Min. Bending			
Radius at 25° C	mm	(=) <25 D	

Typical Packing

Description	Spool Dimensions in mm			
	630	800	950	1000
Flange Dia	630	800	950	1000
Barrel Dia	315	400	400	450
Traverse	450	550	550	620
O.A Width	510	610	610	680
Centre Bore	80	80	80	80
CB to DPC	120	120	120	120
FRP Rod	Length in K.M			
0.8 mm to 1.2 mm	50			
1.5 mm to 2.0 mm		50		
2.1 mm to 2.5 mm		25	50	
2.5 mm to 3.5 mm			12.6	25.2
3.6 mm to 5.0 mm				12.6

Fibre Properties

Specification of Multi Mode Optical fibre					
Transmission Properties	Unit	OM1(62.5/125 μm)	OM2(50/125 μm)	(OM3)	(OM4)
		Values	Values	Values	Values
Attenuation at 850 nm	dB/km	< / = 3.0	< / = 2.9	< / = 2.9	< / = 2.9
Attenuation at 1300 nm	dB/km	< / = 0.7	< / = 0.9	< / = 0.9	< / = 0.9
Bandwidth at 850 nm	MHzKm	> / = 200	> / = 500	> / = 1500	> / = 3500
Bandwidth at 1300 nm	MHzKm	> / = 500	> / = 500	> / = 500	> / = 500
Numerical Aperture		0.275 ± 0.015	0.200 ± 0.015	0.200 ± 0.015	0.200 ± 0.015

Geometrical Properties	Unit	Values	Values	Values	Values
Core diameter	μm	62.5 ± 2.5	50.0 ± 3.0	50.0 ± 3.0	50.0 ± 3.0
Cladding diameter	μm	125 ± 1	125 ± 2	125 ± 2	125 ± 2
Core noncircularity	%	< / = 5	< / = 5	< / = 5	< / = 5
Cladding noncircularity	%	< / = 1	< / = 2	< / = 2	< / = 2
Core concentricity error	μm	< / = 1.5	< / = 2.0	< / = 2.0	< / = 2.0
Primary coating diameter	μm	245 ± 10	245 ± 10	245 ± 10	245 ± 10

Mechanical properties	Unit	Values	Values	Values	Values
Proof test for minimum strain level and Duration of proof test	kpsi, Sec	> / = 100	> / = 100	> / = 100	> / = 100
Change in Attenuation with Bending					
100 Turns on 75mm Dia. Mandrel at 850	dB	< / = 0.50	< / = 0.50	< / = 0.50	< / = 0.50
100 Turns on 75mm Dia. Mandrel at 1300	dB	< / = 0.50	< / = 0.50	< / = 0.50	< / = 0.50
Strippability force to remove primary coating of fibre	Newton	1.3 to 8.9	1.3 to 8.9	1.3 to 8.9	1.3 to 8.9
Fibre Curl	Radius of curve	> / = 4 Mtr	> / = 4 Mtr	> / = 4 Mtr	> / = 4 Mtr
Dynamic tensile strength (unaged)	kpsi	> / = 550	> / = 550	> / = 550	> / = 550
Dynamic tensile strength (Aged)	kpsi	> / = 440	> / = 440	> / = 440	> / = 440
Dynamic Fatigue		> / = 18	> / = 18	> / = 18	> / = 18

Environmental Properties	Unit	Values	Values	Values	Values
Induced attenuation at 850 nm & 1300 nm for Temp. & Humidity cycle from -10°C to +85°C at 98 % humidity (min), ref temp 23°C	dB/Km	< / = 0.15	< / = 0.15	< / = 0.15	< / = 0.15
Induced attenuation at 850 nm & 1300 nm for Temperature cycle from -60°C to +85°C, ref temp 23°C	dB/Km	< / = 0.15	< / = 0.15	< / = 0.15	< / = 0.15
Induced attenuation at 850 nm & 1300 nm for Water Immersion at 23 ± 2°C	dB/Km	< / = 0.15	< / = 0.15	< / = 0.15	< / = 0.15
Induced attenuation at 850 nm & 1300 nm for Accelerated Ageing (Temperature) at 85 ± 2°C, ref temp 23°C	dB/Km	< / = 0.15	< / = 0.15	< / = 0.15	< / = 0.15

Specification of Single Mode Matched Clad Type & Non Zero Dispersion Optical fibre

Transmission Properties	Unit	ITU-T Rec. G-652.D Values	ITU-T Rec. G-655 Values	ITU-T Rec. G-657.A/IEC B6 Values
Attenuation at 1310 nm	dB/km	< / = 0.35	-	< / = 0.35
Attenuation at 1550 nm	dB/km	< / = 0.22	< / = 0.24	< / = 0.22
Attenuation at 1625 nm	dB/km	< / = 0.25	< / = 0.26	< / = 0.25
Attenuation at 1383 ± 3 nm	dB/km	< / = 0.32	-	< / = 0.32
Point discontinuity	dB	< / = 0.05	< / = 0.05	< / = 0.05
Difference in maximum attenuation in the range from 1285 to 1330 nm w.r.t attenuation at 1310 nm	dB/km	< / = 0.03	-	< / = 0.03
Difference in maximum attenuation in the range from 1530 to 1570 nm w.r.t attenuation at 1550 nm	dB/km	< / = 0.02	< / = 0.03	< / = 0.02
Max. chromatic dispersion at 1285-1330 nm wavelength range	ps/nm.km	< / = 3.5	-	< / = 3.5
Max. chromatic dispersion at 1270-1340 nm wavelength range	ps/nm.km	< / = 5.3	-	< / = 5.3
Max. chromatic dispersion at 1530-1565 nm wavelength range	ps/nm.km	-	2.0 to 6.0	-
Max. chromatic dispersion at 12650-1625 nm wavelength range	ps/nm.km	-	4.5 to 11.2	-
Chromatic dispersion at 1550 nm	ps/nm.km	< / = 18.0	-	< / = 18.0
Zero dispersion wavelength	nm	1302 to 1322	-	1302 to 1322
Zero dispersion slope	nm ² .km	< / = 0.092	-	< / = 0.092
PMD at 1310 & 1550 nm (individual)	ps/sqrt.km	< / = 0.20	< / = 0.20	< / = 0.20
Link PMD	ps/sqrt.km	< / = 0.06	< / = 0.04	< / = 0.06
Fibre cut-off wavelength	nm	< / = 1320	-	< / = 1320
Mode field diameter range at 1310 nm	μ m	9.2 ± 0.4	-	9.2 ± 0.4
Mode field diameter range at 1550 nm	μ m	10.5 ± 0.5	9.6 ± 0.4	10.5 ± 0.5

Geometrical Properties	Unit	Values	Values	Values
Cladding diameter	μ m	125 ± 0.7	125 ± 0.7	125 ± 0.7
Cladding noncircularity	%	< / = 0.7	< / = 0.7	< / = 0.7
Primary coating diameter (uncoloured)	μ m	245 ± 5	242 ± 5	245 ± 5
Core/Clad concentricity error	μ m	< / = 0.5	< / = 0.5	< / = 0.5
Coating / Cladding Concentricity error	μ m	< / = 10	< / = 12	< / = 10

Mechanical properties	Unit	Values	Values	Values
Proof test for minimum strain level and Duration of proof test	kpsi, Sec	> 100	> 100	> 100
Change in Attenuation with Bending				
100 Turns on 60mm Dia. Mandrel at 1310	dB	< / = 0.05	-	-
100 Turns on 60mm Dia. Mandrel at 1550	dB	< / = 0.05	< / = 0.05	< / = 0.01
100 Turns on 60mm Dia. Mandrel at 1625	dB	-	< / = 0.01	< / = 0.05
1 Turn on 32 mm Dia. Mandrel at 1310	dB	< / = 0.5	-	-
1 Turn on 32 mm Dia. Mandrel at 1550	dB	< / = 0.5	< / = 0.5	-
1 Turn on 32 mm Dia. Mandrel at 1625	dB	-	< / = 0.5	-
1 Turn on 10 mm Dia. Mandrel at 1550	dB	-	-	< / = 0.2
1 Turn on 10 mm Dia. Mandrel at 1625	dB	-	-	< / = 0.5
Strippability force to remove primary coating of fibre	Newton	1.3 < F < 8.9	1.0 < F < 8.9	1.3 < F < 8.9
Fibre Curl	Radius of curve	> / = 4 Mtr	> / = 4 Mtr	> / = 4 Mtr
Dynamic tensile strength (unaged)	kpsi	> / = 550	> / = 550	> / = 550
Dynamic tensile strength (Aged)	kpsi	> / = 440	> / = 440	> / = 440
Dynamic Fatigue	-	> / = 20	> / = 20	> / = 20

Environmental Properties	Unit	Values	Values	Values
Induced attenuation at 1310 nm & 1550 nm for Temp. & Humidity cycle from -10°C to +85°C at 98 % humidity (min), ref temp 23°C	dB/Km	< / = 0.05	< / = 0.05	< / = 0.05
Induced attenuation at 1310 nm & 1550 nm for Temperature cycle from -60°C to +85°C, ref temp 23°C	dB/Km	< / = 0.05	< / = 0.05	< / = 0.05
Induced attenuation at 1310 nm & 1550 nm for Water Immersion at 23 ± 2°C	dB/Km	< / = 0.05	< / = 0.05	< / = 0.05
Induced attenuation at 1310 nm & 1550 nm for Accelerated Ageing (Temperature) at 85 ± 2°C, ref temp 23°	dB/Km	< / = 0.05	< / = 0.05	< / = 0.05

Note : Other values of G655 Fibre such as Dispersion and MFD can also be provided on request.

OPTICAL FIBRE CABLE HANDLING, INSTALLATION & SAFETY INSTRUCTION

Optical fibre cables can be easily damaged if they are improperly handled or installed. It is imperative that certain procedure be followed during Handling & Installation of these cables to avoid damage. Optical fibre cable requires special care during Handling & Installation to ensure reliable operation. This information given in the document is for Handling drum at various places from receiving in stores till shipment to the site for installation. Proper handling of cable drum decreases probability of accidental damage of cable and personnel. This document also contain some of the basic safety information applicable to Optical fiber cable. Personnel involved in Optical Fiber Cable installation must be aware of all the applicable occupational and health safety regulations and local regulations along with the company safety practices. Failure to follow the same can lead to fatal consequences to them as well as people in the vicinity.

A) Some of the basic guidelines for Cable Drum Handling Unloading the Cable Drums:

Cable drums should be properly unloaded from the truck/container. It is important that cable drum should not be dropped on tiers or floor. If cable drums are dropped on tiers or floor, due the weight of cable and wooden drum, flange of cable drum may get damage and also there are chances that cable will also get damage. The cable drum must be rolled from truck /container on to receiving platform, which is at the same height as the tailgate of truck/container or use forklift to unload drums from truck/container. If inclined ramps are used don't allow drums to roll out of control. Cable drums should be rolled in the direction as indicated on the flange of the drum to avoid any loosing of cable winding. Never step in front of drum rolling down a ramp. Roll each drum away from the bottom of the ramp before handling the next drum otherwise drum may collide to each other.

Storage of Cable Drums:

The drums should always be stored in an upright position i.e on the drum flange edge and not considering flange as base. Storage of drums in an alternative position can lead to winding defects.

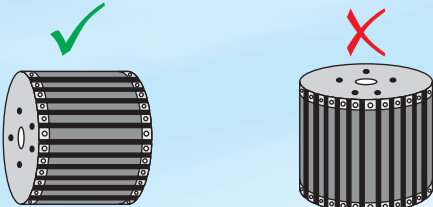

Also follow the below shown figure for stacking the cable drums.

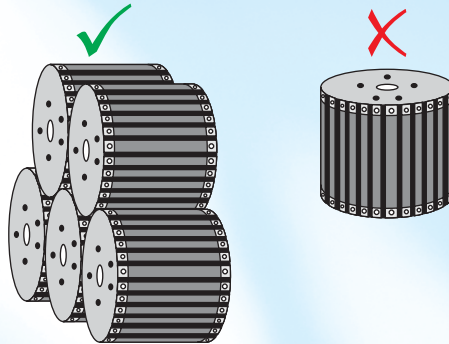

If many drums are opened at a time for inspection / testing, they should be arrange in such a way that flange of first drum should touch the flange of next drum. If this is not followed then there is chance that cable may get damage (flange of first drum may hit the cable on next drum). Correct way of arranging the opened cable drums is shown below.

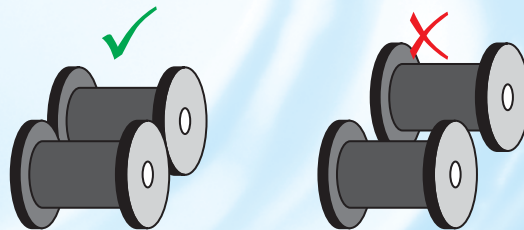

B) Some of the basic guide line for Cable Installation Drum Opening:

Cable drum are packed using wooden packing material. Packing material is nailed on the flange of cable drums. To further strengthen the packing, steel tape is nailed in circumference pattern over both the flanges. To open the cable drum, first cut the steel tape at 8 to 10 places. Remove the entire steel tape. Remove the nails with proper tools and remove the packing material. Nails should be bend to avoid injury to person handling it. Carry out visible inspection of the cable. Before starting installation check for attenuation value.

Packaging Pictures



OPTICAL FIBRE CABLE HANDLING, INSTALLATION & SAFETY INSTRUCTION

Mounting Drum on Pay-off:

For proper installation mount the cable properly on the pay off as shown below. This pay off should be properly lubricated. Height of the payoff should be suitably adjusted so that there is no problem observed while pulling the cable out of the cable drum.

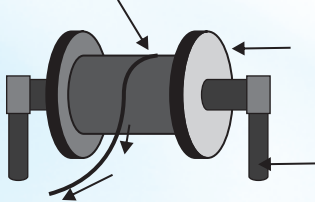

Pulling Technique:

Always use pulling grip to pull the cable. Pulling grip should be fixed with anti twist device (swivel pulling eye) so that cable is not twisted while pulling. Putting the twist in the cable can stress the fibres. If possible monitor the tension being applied to the cable while pulling. In no case the pulling tension should exceed the maximum rated pulling tension of the cable. If possible, use automated puller with tension control or at least a breakaway-pulling eye. Use cable guide to maintain the recommended bend radius. Do not exceed the cable bend radius, exceeding the bend radius harms the fibres. It may not be immediate, it may even take a few years but eventually by exceeding the recommended bend radius of the cable, useful life of the cable reduces. In general the bending radius of a cable is greater than $20D$, where D is the diameter of cable.

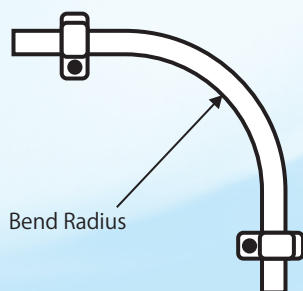

Before blowing the cable inside the duct or directly burring inside the ground, lay out the cable in figure 8 pattern as shown below. Turns the figure 8 cable 360 degree (upside down) before continuing. Pull the cable in opposite direction.

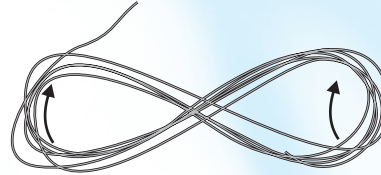

(C) Some of the basic safety guideline

- 1) Never look into a fiber having a laser coupled to it. If eye is accidentally exposed to LASER beam, immediately rush for medical assistance.
- 2) Do not drop fiber pieces on the floor where they will stick in carpets or shoes and be carried elsewhere. These fibre pieces are extremely sharp and can easily penetrate the skin. And any delay in taking the fiber out of body could lead to infection, which is dangerous. Therefore utmost care must be taken to dispose the broken ends of fibers created during termination and splicing.
- 3) Various chemical cleaners and adhesives are used during preparation of Optical Fibre cable for splicing. The safety instructions defined as defined in MSDS (Material Safety Data Sheet) of these materials should be followed.
- 4) Electric arc is generated in fusion splicer while splicing of fibre. It should be ensured that there are no flammable gasses in the vicinity.
- 5) Only work in well ventilated areas.
- 6) Keep all food and beverages out of the work area. If fiber particles are ingested they can cause internal hemorrhaging
- 7) Do not touch your eyes while working with fiber optic systems until they have been thoroughly washed.

Packaging Pictures



DNV-GL

MANAGEMENT SYSTEM CERTIFICATE

Site certificate No.: 48274CC1-2009-AQ-IND-R1A Initial certification date: 05, November, 2009 Valid: 04, November, 2017 - 03, November, 2020

Belongs to Central Office Certificate No.: 48274-2009-AQ-IND-R1A

This is to certify that the management system of

Vindhya Telelinks Limited
Udyog Vihar, P.O. Chorghata, District Rewa - 486 006, Madhya Pradesh, India

has been found to conform to the Quality Management System standard:
ISO 9001:2015

This certificate is valid for the following scope:
DESIGN AND MANUFACTURE OF COPPER COMMUNICATION CABLES (PAIRED/QUAD), SIGNALLING CABLES, LT POWER DISTRIBUTION CABLES & SOLAR ENERGY CABLES

Place and date:
Chennai, 03, November, 2017



For the issuing office:
DNV GL - Business Assurance
ROMA, No. 10, GST Road, Alambur,
Chennai - 600 016, India



Sivaraman Madhyath
Management Representative

The Bulk is a signatory to the IAF MSA

Lack of fulfilment of conditions as set out in the Certification Agreement may render this Certificate invalid.
DNV-GL's website: www.dnvgl.com or by e-mail: certification@dnvgl.com, TEL: +47 22 00 00 00, FAX: +47 22 00 00 00

DNV-GL

MANAGEMENT SYSTEM CERTIFICATE

Site certificate No.: 48274CC2-2009-AQ-IND-R1A Initial certification date: 04, November, 2009 Valid: 04, November, 2017 - 03, November, 2020

Belongs to Central Office Certificate No.: 48274-2009-AQ-IND-R1A

This is to certify that the management system of

Vindhya Telelinks Limited OFC Unit
Udyog Vihar, P.O. Chorghata, District Rewa - 486 006, Madhya Pradesh, India

has been found to conform to the Quality Management System standard:
ISO 9001:2015

This certificate is valid for the following scope:
DESIGN AND MANUFACTURE OF COPPER COMMUNICATION CABLES (PAIRED/QUAD), SIGNALLING CABLES, OPTICAL FIBRE COMMUNICATION (OFC) CABLES INCLUDING SUPPLY OF ITS ACCESSORIES, LT POWER DISTRIBUTION CABLES & SOLAR ENERGY CABLES
MANUFACTURE OF OPTIC FIBRE RIBBON, OPTICAL FIBRE CABLE ASSEMBLIES, FIBRE REINFORCED PLASTIC (FRP) RODS & IMPREGNATED GLASS ROVING (E-GLASS ROVINGS)

Place and date:
Chennai, 03, November, 2017



For the issuing office:
DNV GL - Business Assurance
ROMA, No. 10, GST Road, Alambur,
Chennai - 600 016, India



Sivaraman Madhyath
Management Representative

The Bulk is a signatory to the IAF MSA

Lack of fulfilment of conditions as set out in the Certification Agreement may render this Certificate invalid.
DNV-GL's website: www.dnvgl.com or by e-mail: certification@dnvgl.com, TEL: +47 22 00 00 00, FAX: +47 22 00 00 00

DNV-GL

MANAGEMENT SYSTEM CERTIFICATE

Site certificate No.: 48284CC1-2009-AE-IND-R1A Initial certification date: 18, January, 2009 Valid: 04, November, 2017 - 03, November, 2020

Belongs to Central Office Certificate No.: 48284-2009-AE-IND-R1A

This is to certify that the management system of

Vindhya Telelinks Limited
Udyog Vihar, P.O. Chorghata, District Rewa - 486 006, Madhya Pradesh, India

has been found to conform to the Environmental Management System standard:
ISO 14001:2015

This certificate is valid for the following scope:
DESIGN AND MANUFACTURE OF COPPER COMMUNICATION CABLES (PAIRED/QUAD), SIGNALLING CABLES, LT POWER DISTRIBUTION CABLES & SOLAR ENERGY CABLES

Place and date:
Chennai, 03, November, 2017



For the issuing office:
DNV GL - Business Assurance
ROMA, No. 10, GST Road, Alambur,
Chennai - 600 016, India



Sivaraman Madhyath
Management Representative

The Bulk is a signatory to the IAF MSA

Lack of fulfilment of conditions as set out in the Certification Agreement may render this Certificate invalid.
DNV-GL's website: www.dnvgl.com or by e-mail: certification@dnvgl.com, TEL: +47 22 00 00 00, FAX: +47 22 00 00 00

DNV-GL

MANAGEMENT SYSTEM CERTIFICATE

Site certificate No.: 48284CC2-2009-AE-IND-R1A Initial certification date: 18, January, 2009 Valid: 04, November, 2017 - 03, November, 2020

Belongs to Central Office Certificate No.: 48284-2009-AE-IND-R1A

This is to certify that the management system of

Vindhya Telelinks Limited OFC Unit
Udyog Vihar, P.O. Chorghata, District Rewa - 486 006, Madhya Pradesh, India

has been found to conform to the Environmental Management System standard:
ISO 14001:2015

This certificate is valid for the following scope:
DESIGN AND MANUFACTURE OF COPPER COMMUNICATION CABLES (PAIRED/QUAD), SIGNALLING CABLES, OPTICAL FIBRE COMMUNICATION (OFC) CABLES INCLUDING SUPPLY OF ITS ACCESSORIES, LT POWER DISTRIBUTION CABLES & SOLAR ENERGY CABLES
MANUFACTURE OF OPTIC FIBRE RIBBON, OPTICAL FIBRE CABLE ASSEMBLIES, FIBRE REINFORCED PLASTIC (FRP) RODS & IMPREGNATED GLASS ROVING (E-GLASS ROVINGS)

Place and date:
Chennai, 03, November, 2017



For the issuing office:
DNV GL - Business Assurance
ROMA, No. 10, GST Road, Alambur,
Chennai - 600 016, India



Sivaraman Madhyath
Management Representative

The Bulk is a signatory to the IAF MSA

Lack of fulfilment of conditions as set out in the Certification Agreement may render this Certificate invalid.
DNV-GL's website: www.dnvgl.com or by e-mail: certification@dnvgl.com, TEL: +47 22 00 00 00, FAX: +47 22 00 00 00

DNV-GL

MANAGEMENT SYSTEM CERTIFICATE

Site certificate No.: 18648CC1-2014-HSD-IND-01V Initial certification date: 04, November, 2014 Valid: 04, November, 2017 - 03, November, 2020

Belongs to Central Office Certificate No.: 18648-2014-HSD-IND-01V

This is to certify that the management system of

Vindhya Telelinks Limited
Udyog Vihar, P.O. Chorghata, District Rewa - 486 006, Madhya Pradesh, India

has been found to conform to the Occupational Health and Safety Management System standard:
OHSAS 18001:2007

This certificate is valid for the following scope:
DESIGN AND MANUFACTURE OF COPPER COMMUNICATION CABLES (PAIRED/QUAD), SIGNALLING CABLES, LT POWER DISTRIBUTION CABLES & SOLAR ENERGY CABLES

Place and date:
Chennai, 03, November, 2017



For the issuing office:
DNV GL - Business Assurance
ROMA, No. 10, GST Road, Alambur,
Chennai - 600 016, India



Sivaraman Madhyath
Management Representative

The Bulk is a signatory to the IAF MSA

Lack of fulfilment of conditions as set out in the Certification Agreement may render this Certificate invalid.
DNV-GL's website: www.dnvgl.com or by e-mail: certification@dnvgl.com, TEL: +47 22 00 00 00, FAX: +47 22 00 00 00

DNV-GL

MANAGEMENT SYSTEM CERTIFICATE

Site certificate No.: 18648CC2-2014-HSD-IND-01V Initial certification date: 04, November, 2014 Valid: 04, November, 2017 - 03, November, 2020

Belongs to Central Office Certificate No.: 18648-2014-HSD-IND-01V

This is to certify that the management system of

Vindhya Telelinks Limited OFC Unit
Udyog Vihar, P.O. Chorghata, District Rewa - 486 006, Madhya Pradesh, India

has been found to conform to the Occupational Health and Safety Management System standard:
OHSAS 18001:2007

This certificate is valid for the following scope:
DESIGN AND MANUFACTURE OF COPPER COMMUNICATION CABLES (PAIRED/QUAD), SIGNALLING CABLES, OPTICAL FIBRE COMMUNICATION (OFC) CABLES INCLUDING SUPPLY OF ITS ACCESSORIES, LT POWER DISTRIBUTION CABLES & SOLAR ENERGY CABLES
MANUFACTURE OF OPTIC FIBRE RIBBON, OPTICAL FIBRE CABLE ASSEMBLIES, FIBRE REINFORCED PLASTIC (FRP) RODS & IMPREGNATED GLASS ROVING (E-GLASS ROVINGS)

Place and date:
Chennai, 03, November, 2017



For the issuing office:
DNV GL - Business Assurance
ROMA, No. 10, GST Road, Alambur,
Chennai - 600 016, India



Sivaraman Madhyath
Management Representative

The Bulk is a signatory to the IAF MSA

Lack of fulfilment of conditions as set out in the Certification Agreement may render this Certificate invalid.
DNV-GL's website: www.dnvgl.com or by e-mail: certification@dnvgl.com, TEL: +47 22 00 00 00, FAX: +47 22 00 00 00

DNV BUSINESS ASSURANCE
MANAGEMENT SYSTEM CERTIFICATE

Site Certificate No. 40874CC1-2008-AQ-IND-RvA Rev. 03
Belongs to Main Certificate No. 40874-2008-AQ-IND-RvA

This is to certify that

VINDHYA TELELINKS LIMITED

at

Udyog Vihar, P.O.: Chorhata - 486 006, District: Rewa, Madhya Pradesh, INDIA

has been found to conform to the Quality Management System Standard:

ISO 9001:2008

This certificate is valid for the following scope:

**DESIGN, MANUFACTURE AND SUPPLY OF
COPPER COMMUNICATION CABLES (PAIRED / QUAD),
SIGNALLING CABLES & LT POWER DISTRIBUTION CABLES**

Initial Certification date: 05 November 2008	Place and date of issue: Chennai, 05 November 2014
This Certificate is valid until: 05 November 2017	For the Assessed Unit: DET NORMA VERIEIS CERTIFICEREN B.V., THE NETHERLANDS



The audit has been performed under the supervision of:
Balwant Rai
Lead Auditor



Sivadasan Madiyath
Management Representative

Lack of fulfillment of conditions as set out in the Certification Agreement & the annexure to this certificate may render this Certificate invalid.
Det Norske Veritas Certifications B.V., Postbus 1, 2700 EA Zoetermeer, The Netherlands, TEL: +31 (0)202 506 6000, www.dnv.com
In case of DNV Business Assurance (Quality) Ltd, 27/F, Tower A, No. 100, Kowloon Road East, Kowloon, Hong Kong, TEL: +852 2410 6200, www.dnv.com

DNV BUSINESS ASSURANCE
MANAGEMENT SYSTEM CERTIFICATE

Site Certificate No. 40874CC2-2008-AQ-IND-RvA Rev. 03
Belongs to Main Certificate No. 40874-2008-AQ-IND-RvA

This is to certify that

VINDHYA TELELINKS LIMITED
OFC UNIT

at

Udyog Vihar, P.O.: Chorhata - 486 006, District: Rewa, Madhya Pradesh, INDIA

has been found to conform to the Quality Management System Standard:

ISO 9001:2008

This certificate is valid for the following scope:

**DESIGN, MANUFACTURE AND SUPPLY OF COPPER COMMUNICATION CABLES (PAIRED / QUAD),
SIGNALLING CABLES, OPTICAL FIBRE COMMUNICATION (OFC) CABLES INCLUDING
SUPPLY OF ITS ACCESSORIES & LT POWER DISTRIBUTION CABLES
MANUFACTURE AND SUPPLY OF OPTIC FIBRE RIBBONS, FIBRE REINFORCED PLASTIC (FRP) RODS
& IMPREGNATED GLASS ROVINGS (E-GLASS ROVINGS)**

Initial Certification date: 05 November 2008	Place and date of issue: Chennai, 05 November 2014
This Certificate is valid until: 05 November 2017	For the Assessed Unit: DET NORMA VERIEIS CERTIFICEREN B.V., THE NETHERLANDS



The audit has been performed under the supervision of:
Balwant Rai
Lead Auditor



Sivadasan Madiyath
Management Representative

Lack of fulfillment of conditions as set out in the Certification Agreement & the annexure to this certificate may render this Certificate invalid.
Det Norske Veritas Certifications B.V., Postbus 1, 2700 EA Zoetermeer, The Netherlands, TEL: +31 (0)202 506 6000, www.dnv.com
In case of DNV Business Assurance (Quality) Ltd, 27/F, Tower A, No. 100, Kowloon Road East, Kowloon, Hong Kong, TEL: +852 2410 6200, www.dnv.com

DNV BUSINESS ASSURANCE
MANAGEMENT SYSTEM CERTIFICATE

Site Certificate No. 46856CC1-2009-AE-IND-RvA Rev. 02
Belongs to Main Certificate No. 46856-2009-AE-IND-RvA

This is to certify that

VINDHYA TELELINKS LIMITED

at

Udyog Vihar, P.O.: Chorhata - 486 006, District: Rewa, Madhya Pradesh, INDIA

has been found to conform to the Environmental Management System Standard:

ISO 14001:2004

This certificate is valid for the following scope:

**DESIGN, MANUFACTURE AND SUPPLY OF
COPPER COMMUNICATION CABLES (PAIRED / QUAD),
SIGNALLING CABLES & LT POWER DISTRIBUTION CABLES**

Initial Certification date: 18 January 2010	Place and date of issue: Chennai, 05 November 2014
This Certificate is valid until: 05 November 2017	For the Assessed Unit: DET NORMA VERIEIS CERTIFICEREN B.V., THE NETHERLANDS



The audit has been performed under the supervision of:
Balwant Rai
Lead Auditor



Sivadasan Madiyath
Management Representative

Lack of fulfillment of conditions as set out in the Certification Agreement & the annexure to this certificate may render this Certificate invalid.
Det Norske Veritas Certifications B.V., Postbus 1, 2700 EA Zoetermeer, The Netherlands, TEL: +31 (0)202 506 6000, www.dnv.com
In case of DNV Business Assurance (Environmental) Ltd, 27/F, Tower A, No. 100, Kowloon Road East, Kowloon, Hong Kong, TEL: +852 2410 6200, www.dnv.com

DNV BUSINESS ASSURANCE
MANAGEMENT SYSTEM CERTIFICATE

Site Certificate No. 46856CC2-2009-AE-IND-RvA Rev. 02
Belongs to Main Certificate No. 46856-2009-AE-IND-RvA

This is to certify that

VINDHYA TELELINKS LIMITED
OFC UNIT

at

Udyog Vihar, P.O.: Chorhata - 486 006, District: Rewa, Madhya Pradesh, INDIA

has been found to conform to the Environmental Management System Standard:

ISO 14001:2004

This certificate is valid for the following scope:

**DESIGN, MANUFACTURE AND SUPPLY OF COPPER COMMUNICATION CABLES (PAIRED / QUAD),
SIGNALLING CABLES, OPTICAL FIBRE COMMUNICATION (OFC) CABLES INCLUDING
SUPPLY OF ITS ACCESSORIES & LT POWER DISTRIBUTION CABLES
MANUFACTURE AND SUPPLY OF OPTIC FIBRE RIBBONS, FIBRE REINFORCED PLASTIC (FRP) RODS
& IMPREGNATED GLASS ROVINGS (E-GLASS ROVINGS)**

Initial Certification date: 18 January 2010	Place and date of issue: Chennai, 05 November 2014
This Certificate is valid until: 05 November 2017	For the Assessed Unit: DET NORMA VERIEIS CERTIFICEREN B.V., THE NETHERLANDS



The audit has been performed under the supervision of:
Balwant Rai
Lead Auditor



Sivadasan Madiyath
Management Representative

Lack of fulfillment of conditions as set out in the Certification Agreement & the annexure to this certificate may render this Certificate invalid.
Det Norske Veritas Certifications B.V., Postbus 1, 2700 EA Zoetermeer, The Netherlands, TEL: +31 (0)202 506 6000, www.dnv.com
In case of DNV Business Assurance (Environmental) Ltd, 27/F, Tower A, No. 100, Kowloon Road East, Kowloon, Hong Kong, TEL: +852 2410 6200, www.dnv.com

DNV BUSINESS ASSURANCE
MANAGEMENT SYSTEM CERTIFICATE

Site Certificate No. 16648SCC1-2014-HSO-IND-DNV
Belongs to Main Certificate No. 16648S-2014-HSO-IND-DNV

This is to certify that

VINDHYA TELELINKS LIMITED

at

Udyog Vihar, P.O.: Chorhata - 486 006, District: Rewa, Madhya Pradesh, INDIA

has been found to conform to the Occupational Health and Safety Management System Standard:

OHSAS 18001:2007

This certificate is valid for the following scope:

**DESIGN, MANUFACTURE AND SUPPLY OF
COPPER COMMUNICATION CABLES (PAIRED / QUAD),
SIGNALLING CABLES & LT POWER DISTRIBUTION CABLES**

Initial Certification date: 04 November 2014	Place and date of issue: Chennai, 05 November 2014
This Certificate is valid until: 05 November 2017	For the Certifying Unit: DNV BUSINESS ASSURANCE INDIA PVT LTD MUMBAI, INDIA



The audit has been performed under the supervision of:
Balwant Rai
Lead Auditor



Sivadasan Madiyath
Management Representative

Lack of fulfillment of conditions as set out in the Certification Agreement & the annexure to this certificate may render this Certificate invalid.
Det Norske Veritas Certifications B.V., Postbus 1, 2700 EA Zoetermeer, The Netherlands, TEL: +31 (0)202 506 6000, www.dnv.com
In case of DNV Business Assurance (Occupational Health and Safety) Ltd, 27/F, Tower A, No. 100, Kowloon Road East, Kowloon, Hong Kong, TEL: +852 2410 6200, www.dnv.com

DNV BUSINESS ASSURANCE
MANAGEMENT SYSTEM CERTIFICATE

Site Certificate No. 16648SCC2-2014-HSO-IND-DNV
Belongs to Main Certificate No. 16648S-2014-HSO-IND-DNV

This is to certify that

VINDHYA TELELINKS LIMITED
OFC UNIT

at

Udyog Vihar, P.O.: Chorhata - 486 006, District: Rewa, Madhya Pradesh, INDIA

has been found to conform to the Occupational Health and Safety Management System Standard:

OHSAS 18001:2007

This certificate is valid for the following scope:

**DESIGN, MANUFACTURE AND SUPPLY OF COPPER COMMUNICATION CABLES (PAIRED / QUAD),
SIGNALLING CABLES, OPTICAL FIBRE COMMUNICATION (OFC) CABLES INCLUDING
SUPPLY OF ITS ACCESSORIES & LT POWER DISTRIBUTION CABLES
MANUFACTURE AND SUPPLY OF OPTIC FIBRE RIBBONS, FIBRE REINFORCED PLASTIC (FRP) RODS
& IMPREGNATED GLASS ROVINGS (E-GLASS ROVINGS)**

Initial Certification date: 04 November 2014	Place and date of issue: Chennai, 05 November 2014
This Certificate is valid until: 05 November 2017	For the Certifying Unit: DNV BUSINESS ASSURANCE INDIA PVT LTD MUMBAI, INDIA



The audit has been performed under the supervision of:
Balwant Rai
Lead Auditor



Sivadasan Madiyath
Management Representative

Lack of fulfillment of conditions as set out in the Certification Agreement & the annexure to this certificate may render this Certificate invalid.
Det Norske Veritas Certifications B.V., Postbus 1, 2700 EA Zoetermeer, The Netherlands, TEL: +31 (0)202 506 6000, www.dnv.com
In case of DNV Business Assurance (Occupational Health and Safety) Ltd, 27/F, Tower A, No. 100, Kowloon Road East, Kowloon, Hong Kong, TEL: +852 2410 6200, www.dnv.com

DNV-GL

MANAGEMENT SYSTEM CERTIFICATE

Certificate No: 180851-2015-AQ-IND-014 Initial certification date: 17, June, 2015 Valid: 17, June, 2018 - 16, June, 2021

This is to certify that the management system of

Birla Cable Limited
(Formerly Birla Ericsson Optical Ltd.)
Udyog Vihar, P.O. Chohata, Rewa - 486 006, Madhya Pradesh, India

has been found to conform to the Quality Management System standard:
ISO 9001:2015

This certificate is valid for the following scope:
Design, development and manufacture of optical fibre cables, ribbon type optical fibre cables, polyethylene insulated jelly filled telecommunication cables, copper communication cables, insulated wires & cables, electric conductors and supply of accessories for optical fibre cables & copper cables

Place and date:
Chennai, 19, June, 2018

For the issuing office:
DNV GL - Business Assurance
SØKNA, No. 19, 087 Strand, Alnshavn,
Chennai - 600 016, India

The Birla is a signatory to the IAF MSA

Link of fulltext of conditions as set out in the Certification Agreement can be found in the Certificate holder's account.

DNV-GL

MANAGEMENT SYSTEM CERTIFICATE

Certificate No: 180851-2015-EM-IND-014 Initial certification date: 17, June, 2015 Valid: 17, June, 2018 - 16, June, 2021

This is to certify that the management system of

Birla Cable Limited
(Formerly Birla Ericsson Optical Ltd.)
Udyog Vihar, P.O. Chohata, Rewa - 486 006, Madhya Pradesh, India

has been found to conform to the Environmental Management System standard:
ISO 14001:2015

This certificate is valid for the following scope:
Design, development and manufacture of optical fibre cables, ribbon type optical fibre cables, polyethylene insulated jelly filled telecommunication cables, copper communication cables, insulated wires & cables, electric conductors and supply of accessories for optical fibre cables & copper cables

Place and date:
Chennai, 19, June, 2018

For the issuing office:
DNV GL - Business Assurance
SØKNA, No. 19, 087 Strand, Alnshavn,
Chennai - 600 016, India

The Birla is a signatory to the IAF MSA

Link of fulltext of conditions as set out in the Certification Agreement can be found in the Certificate holder's account.

DNV-GL

MANAGEMENT SYSTEM CERTIFICATE

Certificate No: 241970-2015-OSH-IND-014 Initial certification date: 17, June, 2015 Valid: 18, June, 2018 - 17, June, 2021

This is to certify that the management system of

Birla Cable Limited
(Formerly Birla Ericsson Optical Ltd.)
Udyog Vihar, P.O. Chohata, Rewa - 486 006, M. P, India

has been found to conform to the Occupational Health and Safety Management System standard:
OHSAS 18001:2007

This certificate is valid for the following scope:
Design, Development and Manufacture of Optical Fibre Cables, Ribbon Type Optical Fibre Cables, Polyethylene Insulated Jelly Filled Telecommunication Cables, Copper Communication Cables, Insulated Wires & Cables, Electric Conductors and Supply of Accessories for Optical Fibre Cables & Copper Cables

Place and date:
Amsterdam, 28, June, 2018

For the issuing office:
DNV GL - Business Assurance
SØKNA, No. 19, 087 Strand, Alnshavn,
Chennai - 600 016, India

The Birla is a signatory to the IAF MSA

Link of fulltext of conditions as set out in the Certification Agreement can be found in the Certificate holder's account.

Telcordia Certificate Number 190601
June 24, 2015 (revised for Company name change on Nov 26, 2016)

Certified by
Telcordia
Network & Product Integrity

GR-20-CORE CONFORMANCE CERTIFICATE

Certification Type:	Product Conformance
Testing Criteria:	Telcordia GR-20-CORE Issue 4
Manufacturer:	BIRLA CABLE LIMITED (formerly Birla Ericsson Optical Limited) P.O. CHORHATA, REWA - 486 006 (M.P.), INDIA: Tel: +91 7682 400 400 Email: info@birlacable.com Web: www.birlacable.com
Product:	Optical Cable Loose Tube, All Di-Electric
Testing Completion Date:	June, 2015
Certificate Number:	160604

Telcordia has completed an analysis of Birla All Di-Electric Loose Tube Cable. Product is deemed to conform with all relevant requirements.

For details on the scope of the analysis and results, please refer to Telcordia Report DA-2089, *Analysis of the Birla Furukawa G.652D Optical Fiber and Birla Ericsson Single Sheath Duct Optical Cable (G.652D) Family Against GR-20-CORE, Issue 4* available from BIRLA CABLE LIMITED.

Richard G. Kluge
Richard G. Kluge
Engineering Manager
Telcordia Network & Product Integrity (NPI)

Statement of Confirmation

TUV

No.: CE_98/17_960.00

Client's reference - Technical File Number: BEOL2015

Name & Address of the Manufacturer:
Birla Ericsson Optical Ltd.
P.O. Chohata Udyog Vihar
Rewa (M.P.)-486006
INDIA

Product Nomenclature: Optical Fibre Cables.

Type/Model:	Direct Buried Cable
FTTx Cable	Aerial (Pta-D) Cable
Micro Cable	ADSS Cable
Tactical Cable	Indoor Cable
Direct Cable	Fibre To Antenna (FTA) Cable
Connectorized Cable	

Review Results/Observations:
The Technical File referenced above submitted by the manufacturer has been reviewed for its document contents.
The Technical File generally covers the documentation content requirements of the European Directives:
- RoHS Regulation (2011/65/EC)

Standards Referred to: IEC 62321

Other Standards Referred to: EN 60974-1-20, EN 60974-1-22, EN 60974-1-23

Document issued by the Manufacturer: Declaration of Conformity.

Marking on the Product:

Date of Review: 20th October 2015

K.M.Deshmukh
Senior Manager - Product Certifications.

M.S.Ogale
Head - Homologation & Product Certification.

(This Statement of confirmation is valid under the conditions stated therein)

Job#: 8112383150 Page 1 of 2

UNDERWRITERS LABORATORIES INC.
INSPECTION REPORT - Type L Service
E3200410098121541

Date:	08/13/2008	File Number:	E320004
Responsible Office:	Bangalore	Volume:	1
Inspection Center:	S24	Account / Order Number:	0464 - 7
Product Category:	OCN (Communications Cable Verified in Accordance with National or International Specifications) Data Transmission Cable Verified in Accordance with National or International Specifications	ULi, Representative ID:	Gurpreet S Lamba 08264
Subscriber - Factory Number:	REWA MSP 486006 INDIA	Factory Representative:	Shekhar Banerjee
Manufacturer Name:	BIRLA ERICSSON OPTICAL LTD	Factory Rep Phone:	07862-400580, 400400
Manufacturer Address:	PO CHORHATA, REWA MSP 486006 INDIA	Factory Rep Email:	shekhar@birlaericsson.com

Nature of Visit: Initial Production Inspection Sample Status: Samples not required

Listing/Classification/Recognized (UL/IEC) Component Marks Used: Yes (UL/IEC) Component Marks Removed: No

Variation Notice Issued: No

Comments After Submission:

PRODUCT DOCUMENTS / PRODUCTION READY VISIT			
Model	Product	Class	Section / Multiple Listed
TIA/EIA-568-B.2 CAT 5E, 4FR	Data Transmission Cable		1 No

SAMPLE DOCUMENTS

If samples are required to be sent to ULi Laboratory, indicate below. If required samples are not sent, explain in the Comments area.

Type/Model/Cat./No./ULi	Name	Sample Tag Number	Shipped to Office
No. Sample:			

Additional Comments:
(1) IPI has been carried out successfully.
(2) I have authorized the Manufacturer to ship their Products covered in the FUS Procedure with Marking as per the FUS Procedure.
(3) Manufacturer will receive ULi stickers from ULi Singapore office within 10 Days.



VINDHYA TELELINKS LIMITED

BIRLA CABLE LIMITED

Registered Office & Works :

Udyog Vihar, P.O. Chorhata, Rewa, Madhya Pradesh - 486006 INDIA

Contact For Enquiries:

Sharda Terraces, 9th Floor, Plot No. 65, Sector-11,
CBD Belapur, Navi Mumbai - 400614 INDIA

Tel: +91 22 4126 8855 / 2756 0463 / 2756 0464. Fax: +91 22 4126 8899

Email: info@birlacable.com, info@vtlrewa.com

Branches:

AHMEDABAD

A 801, Sivanta One, Opp Bank Of Baroda,
Near V.S.Hospital, Ashram Road, Paldi,
Ahmedabad - 380 007 INDIA

GOA

Plot Nos.L62 to L64A,
Verna Industrial Estate,
Verma Salcete - 403 722, Goa, INDIA

BANGALORE

287, 15th Main, RMV Extension, Sadashiv Nagar,
Nr. Nagasena School, Bangalore-560 080,
Karnataka, INDIA

HYDERABAD

Office No 603/1, Sixth Floor Block -1, White
House Municipal No -6-3-1192/1/603/1
Begumpet Hyderabad-500 016, INDIA

CHENNAI:

GR Towers, 2nd Floor, 136, Nelson Manickam
Road, Aminjikarai, Chennai - 600029,
Tamil Nadu, INDIA

KOLKATA

27-B, Camac Street,
5th Floor, Kolkata - 700 016,
West Bengal, INDIA